

MADISON COUNTY WATER DEPARTMENT

SPECIFICATIONS AND PROCEDURES

FOR THE INSTALLATION OF

DRINKING WATER INFRASTRUCTURE

EFFECTIVE

MARCH 19, 2018

TABLE OF CONTENTS

SECTION	PAGE
100 GENERAL.....	1
200 APPLICABILITY AND PROCEDURES	2
A. REQUIREMENTS FOR NEW DEVELOPMENTS	2
B. ADDITIONAL REQUIREMENTS FOR PRIVATE PROPERTIES	3
C. CURRENT WATER AVAILABILITY AND TAP FEES.....	3
300 WATER DISTRIBUTION REQUIREMENTS AND PLANS	4
400 AS-BUILT DRAWINGS.....	6
500 FINAL COMPLETION AND ACCEPTANCE	7
A. MINIMUM REQUIREMENTS FOR FINAL ACCEPTANCE.....	7
B. PROCESS TO RECEIVE WATER METER	7
600 MATERIALS.....	8
A. BALL CORPORATION VALVES.....	8
B. CURB STOPS.....	8
C. BACKFLOW DUAL CHECK VALVES.....	9
D. SERVICE SADDLES.....	9
E. STAINLESS STEEL TAPPING SLEEVES	10
F. TAPPING VALVES	10
G. TRACER WIRE.....	11
H. PLASTIC METER BOXES.....	11
I. MEGA LUGS FOR PVC.....	12
J. GATE VALVES	12
K. PVC WATER MAIN.....	13
L. VALVE BOXES	13
M. FIRE HYDRANTS	14
N. SERVICE TUBING.....	15
O. ENCASEMENT PIPE FOR LONG SIDE SERVICES.....	16
P. STEEL CASING PIPE FOR ROADWAY BORES	16
Q. PRECAST CONCRETE VAULT	17
R. ALUMINUM HATCH	17
S. FITTINGS.....	17
T. LOCATION TAPE	18
U. DUCTILE IRON PIPE	18

700	INSTALLATION	20
	A. FIRE HYDRANTS	20
	B. SERVICE LINES AND METER BOXES	21
	C. DEWATERING TRENCHES	22
	D. TRENCH STABILIZATION	22
	E. LAYING PIPE IN TRENCHES, ALONG ROADS, EASEMENTS	22
	F. THRUST RESTRAINT	24
	G. TAPPING EXISTING WATER MAINS	25
	H. VALVE BOXES	25
800	JACKING AND BORING ROADWAYS	26
900	PRESSURE TESTING REQUIREMENTS	28
	A. GENERAL	28
	B. TESTING PROCEDURES	28
	C. ALLOWABLE LEAKAGE	29
1000	DISINFECTION AND SAMPLING	30
	A. GENERAL	30
	B. DISINFECTION METHOD	30
	C. SAMPLING	31
1100	APPENDIX – DETAILED DRAWINGS	32
	Figure 1 – Fire Hydrant Installation.....	33
	Figure 2 – Post Hydrant Detail	34
	Figure 3 – Service Line Installation.....	35
	Figure 4 – Earth Excavation for PVC and Ductile Iron.....	36
	Figure 5 – Rock Excavation for PVC and Ductile Iron.....	37
	Figure 6 – Ditch and Obstruction Crossing Detail.....	38
	Figure 7 – Concrete Encasement for Creek and Ditch Crossing Detail	39
	Figure 8 – Creek and River Crossing Detail.....	40
	Figure 9 – Blow Off Detail	41
	Figure 10 – Blow Off Detail Using Fire Hydrant	42
	Figure 11 – Dead End Anchor Block Detail.....	43
	Figure 12 – Water Main Trench Details	44
	Figure 13 – Concrete Thrust Block Detail.....	45
	Figure 14 – Tapping Sleeve and Valve Detail.....	46
	Figure 15 – Valve Box Detail	47
	Figure 16 – Roadway Boring Detail	48
	Figure 17 – Anchor Block for Reducer Detail.....	49
	PRV Figure – Pressure Reducing Valve and Vault	50

100 GENERAL

This specification defines procedures, materials and installation requirements for the installation of new ductile iron and polyvinylchloride (PVC) water mains, valves, fittings, and appurtenances in the Madison County Water Department (MCWD) Service Area. These specifications shall be followed in conjunction with Madison County's *Subdivision Regulations*, latest revision. These specifications are intended for use by subdivision developers and the developers' engineers and contractors. Specific references to engineers and contractors represent the normal roles and responsibilities.

- All proposed projects are subject to the approval of the Madison County Commission before construction is authorized.
- All work must be on public right-of-way or utility easement dedicated to Madison County.
- The Contractor or Developer shall agree to maintain the work in good order for a period of one year from the date the work is accepted by the MCWD.
- No meters will be set until the MCWD has issued the final acceptance letter for the said project.
- Permission to open cut or bore a county road must be approved by the appropriate Madison County District Commissioner. Permission to cut a private driveway must be obtained from the property owner.

200 APPLICABILITY AND PROCEDURES

A. REQUIREMENTS FOR NEW DEVELOPMENTS

In order for a new subdivision, trailer park or private development to be approved by the Madison County Water Department, the following procedure must be followed (for private properties, see Section 200.B for additional requirements):

- The Developer/Engineer shall provide MCWD with two (2) sets of the **water distribution plan drawing** (see Section 300 for drawing requirements) and one (1) copy of the construction plans for all proposed utilities. The plans must include alignment for Huntsville Utilities primary power. However, complete drawings are required for stormwater piping and sanitary sewer, if applicable, for both gravity lines and force mains. The drawings must be developed by a Professional Engineer, licensed by the Alabama State Board of Registration for Professional Engineers and Land Surveyors and must bear the seal of the Engineer. MCWD will review the drawings to make sure the project meets requirements set forth by the Alabama Department of Environmental Management (ADEM) and MCWD and to determine if the current MCWD facilities can support the project. If the project is to have multiple phases, the Developer is also to provide MCWD with a layout drawing of the entire project in order for future projections to be made. In addition, if available, MCWD would like a copy of the water distribution plan on disk (AutoCAD).
- MCWD will notify the Engineer after the water distribution plan has been reviewed. If any corrections are required, MCWD will provide a marked-up copy of said drawing. The Engineer shall correct the drawing and provide MCWD with two copies of the corrected water distribution plan. If any upgrades are necessary to the MCWD facilities to support the project, the drawing shall show all additions.
- Once plans are approved by MCWD, the Owner/Developer must pay the appropriate **water availability fees and tap fees**. The fees are posted on the Madison County website at <https://www.madisoncountyal.gov/departments/water-department/madison-county-water-department-rates-and-fees/-fsiteid-1>. The fees, as of the publication date, are provided in Section 200.C. MCWD will then furnish a letter stating that water is available for the project. If any changes or upgrades are necessary to the MCWD facilities, these items will also be stated in the letter furnished by MCWD.
- MCWD will sign the **proposed plat** once all fees have been paid. Appointments are required for obtaining signatures on proposed plats in order to ensure authorized individuals are available. Schedule appointments with John Buxton, Water Engineering Manager, at 256-746-2870 at least one work day prior to requiring signatures. Failure to schedule an appointment may result in authorized signatories being unavailable.
- A **pre-construction meeting** can be scheduled once MCWD has, in hand, a copy of the proposed plat with all the governing authorities' signatures on plat. MCWD will, at this time, inspect all materials on the job site, and upon approval, the Contractor can commence work.
- Once the project is completed and approved by the County Engineer, the Developer/Engineer is to provide MCWD with two (2) sets of the water distribution **as-built drawing** (one original – Mylar or similar material; and one copy) developed by a Professional Engineer. The drawing must bear the seal of an engineer licensed by the Alabama State Board of Registration for Professional Engineers and Land Surveyors. In addition to the paper copies, the as-built

drawing shall be submitted in digital format. Please see Section 400 for as-built drawing requirements.

- A Madison County Water Department Representative (MCWDR) will then compare the as-built drawing to the field conditions and notify the Contractor and Engineer of any necessary changes.
- Once all work is complete, the minimum requirements for final acceptance have been met (see Section 500), and the MCWDR approves the as-built, MCWD will notify the Contractor, Engineer and Developer, by letter, that the project is complete and accepted into the MCWD distribution system with a one year warranty. Water meters may be set by MCWD at this point, if all other criteria have been met (see Section 500.B).
- The **final plat** can be signed once the said project is complete and accepted. However, the final plat can be signed before final acceptance of the project if the Developer/Engineer provides proof of a guarantee (for the water items) paid to the Madison County Public Works Department for the amount set forth in Madison County's *Subdivision Regulations*. Appointments are required for obtaining signatures on final plats in order to ensure authorized individuals are available. Schedule appointments with John Buxton, Water Engineering Manager, at 256-746-2870 at least one work day prior to requiring signatures. Failure to schedule an appointment may result in authorized signatories being unavailable.

B. ADDITIONAL REQUIREMENTS FOR PRIVATE PROPERTIES

- MCWD will accept water improvements on private properties only if a 30' utility easement (from centerline of road) is deeded to Madison County.
- The utility easement must be along any roads serving lots in the development.
- MCWD must have access to the easement at all times.
- The easement can only be used for MCWD facilities.
- MCWD will not be responsible for maintaining the grounds of the easement.
- The easement description must be reviewed by the Madison County Attorney and approved by the Madison County Commission. MCWD requires a copy of the fully executed deed before any work begins.
- Private developments will be required to follow guidelines and procedures established in Section 200.A (with the exception of the proposed and final plat requirements) in order to not adversely impact existing customers.
- Based on hydraulic and water quality factors, Madison County reserves the right to reduce water main size and fire hydrant spacing requirements.

C. CURRENT WATER AVAILABILITY AND TAP FEES

- \$850.00 -- Availability Fee Per Lot
- \$300.00 -- 6-inch Tap Fee
- \$400.00 -- 8-inch Tap Fee
- \$500.00 -- 10-inch Tap Fee
- \$600.00 -- 12-inch Tap Fee

300 WATER DISTRIBUTION REQUIREMENTS AND PLANS

The Developer/Engineer shall provide MCWD with two (2) sets of the **water distribution plan drawing**. The drawing must be developed by a Professional Engineer, licensed by the Alabama State Board of Registration for Professional Engineers and Land Surveyors, and must bear the seal of the Engineer.

The water system requirements are listed below:

- **Valves**
Three (3) - or four (4)-way valve systems shall be installed at all intersections. Locate valves outside of proposed roadways – no valves are allowed in pavement. Valves are to be placed at PC (Point of Curve) and/or PT (Point of Tangent) in all intersections to ensure all valves are located outside of pavement and concrete areas.
- **Fire hydrants**
Fire hydrants shall be 750 feet apart – all measurements start from an existing fire hydrant. If there is no existing fire hydrant within 750’ of beginning of new project, begin project with a new fire hydrant. Locate fire hydrants on nearest lot line or intersection corner.
- **Meter Boxes**
Meter boxes are to be located at lot corners or center of lots, to minimize any conflicts with other utilities. For developments with open ditches - install meter box one foot behind U & D Easement; for curb and gutter - 12’ back of curb.
- **Service Lines and Taps**
Short-side service line taps are to be made at lot corners or center of lots. Long-side meter taps are to be made either at lot corners or center of lots, whichever is the closest to extend service line across roadway to proposed lot corner and to minimize conflicts with other utilities. The taps must be directly across the road from the meter and meter box. There is to be no more than two (2) taps at one location, and the service lines must run in the same direction. Short-side and long-side meter taps are not to be placed at same location. There must be a separation of at least 5 feet.
- **Water Main**
The water main is to be eight-inch (8”) PVC along streets and three-inch (3”) PVC in cul-de-sacs. Eight-inch (8”) DUCTILE IRON is required under all storm water culverts, roadway crossings, and open drainage ditches and streams. The location of the water main is dependent on the situation. For open ditches, the center line of water main should be 1’ inside the ROW. For curb and gutter with 50’ ROW, the center line of the water main should be 9’ back of curb.
- **Pressure Reduction Requirement** *See PRV Figure in Appendix*
Madison County Water Department may require the installation of a Pressure Reducing Valve and Vault (PRVV) in subdivisions or new phases of a subdivision when the estimated, low-demand, peak pressure is determined to exceed 130 psi for the lot with the lowest elevation. Additionally, a PRVV may be required for a subdivision where two water feeds are necessary and the available feeds are located in different pressure zones.

The PRVV shall be installed at either:

- 1) the entrance to the new subdivision,
- 2) the beginning of a new phase, or

3) at a location determined by the Engineer and Madison County Water Department when options 1) and 2) would not provide 60 to 80 psi at the highest elevation.

- **Dead-end Mains**

- Cul-de-sacs: Three-inch mains in cul-de-sacs must have a post hydrant at the end of the main for flushing.
- Mains not terminating in cul-de-sacs: Mains which do not terminate in cul-de-sacs must have a fire hydrant blow-off at the end unless the main will be continued in a future phase.
- Mains continuing in future phases: If the 750 foot fire hydrant spacing can be met, then mains continuing into subsequent phases can be terminated with a blow-off valve.

- **Separation Between Water and Primary Power**

In new developments with underground power, water mains shall be placed on the opposite side of road from primary power. Prior approval by Madison County Water Department is required for situations where water and primary power are not on opposite sides of the road.

- **Separation Between Water and Sewer**

The minimum separation distance from water mains shall be the greater of the following limits or limits established by ADEM or the State of Alabama Department of Public Health (ADPH): 10 feet horizontal separation from water mains and 1.5 feet vertical separation below water mains. Cross existing water mains as perpendicularly as possible. Encase the sewer with concrete when separation distance cannot be maintained.

- **Additional Required Details**

- elevation contours in 10-foot increments, and
- location and sizes of meters, valves, fittings, service lines, and water mains.

400 AS-BUILT DRAWINGS

The Developer/Engineer shall provide MCWD with two (2) sets of drawings showing all water distribution as-built information. These water distribution **as-built drawings** (one original – Mylar or similar material; and one copy) must be developed by a Professional Engineer licensed by the Alabama State Board of Registration for Professional Engineers and Land Surveyors and must bear the seal of the Engineer. In addition to the paper copies, the as-built drawings shall be submitted in digital format on disk or by email, in either a DXF or DWG file format using State Plane NAD 1983 Alabama East.

The drawings shall contain, at a minimum, the following information:

- Location of all valves with at least two (2) dimensions, three (3) wherever possible. Use distance and general direction from back of curb, center line of roadway, fire hydrants, or other permanent objects. Distance from power poles or transformers are acceptable only as a third dimension;
- Location of all tees, reducers, and sleeves buried under ground. Give two-way dimension to nearest valve or other permanent object;
- Location of all service lines, meter boxes, and service saddles. Provide two-dimensional distances from property corners, back of curb and other permanent objects;
- Location and size of mains from property corners, right-of-way, easement lines, back of curb or roadway centerlines every 500 feet along straight sections and every 100 feet, or each property corner (whichever is less), along curved sections;
- Location and dimensions, both horizontally and vertically, at any and all crossings of other utilities, including storm drains and culverts, with dimensions given both over and under the water mains;
- Any and all variances from the drawings and plans clearly labeled and noted;
- Locations where ductile iron is used and the transition back to PVC;
- Total length of each size main installed; and
- Dimensions expressed in linear foot.

500 FINAL COMPLETION AND ACCEPTANCE

When the project is complete, the MCWDR shall inspect the work. If completed in accordance with these specifications, the MCWD shall issue the Developer a letter of final acceptance which shall mark the beginning of the Developer's one year warranty period. If the work is found to be incomplete or not in accordance with specifications, the MCWDR shall notify the Developer and Contractor of the reasons for non-acceptance.

A. MINIMUM REQUIREMENTS FOR FINAL ACCEPTANCE

- Pressure test is passed;
- Water samples pass ADEM and ADPH requirements;
- As-built drawings are complete and accurate;
- All valves and valve boxes are to grade and operable;
- All fire hydrants are to grade, operable and properly located at the intersection of property lines and right-of-way or easement lines (unless other location specified) with pumper nozzles facing the street;
- All service line stub-outs are at, or near, the right-of-way or easement lines, with meter boxes 3" above final ground grade and/or a minimum of 6" above top of curb; and
- All temporary taps and/or injection taps and blow-offs are capped and removed.

B. PROCESS TO RECEIVE WATER METER

- Receive final acceptance of subdivision;
- Set up a billing account, for each address, with Huntsville Utilities;
- Appear in person at the Madison County Water Department at 266-B Shields Rd. with utility account information, pay the appropriate fees and apply for a meter; a representative will issue a flag to be placed inside the meter box;
- A Madison County Water Department employee will install the water meter and backflow;
- Reasons for meter installation delays: flag not in box; meter box, meter lid, curb stop and/or service line not meeting Madison County Water Department Specifications. Once the problems have been corrected, a water department employee will then set the water meter. If unauthorized usage is discovered (such as being hooked up directly to the curb stop) or if the meter box, meter lid, curb stop and/or service line is damaged, the meter will not be installed, the curb stop will be locked off, and the responsible party will be charged a fee. Once the fee is paid and/or the problems have been corrected, a water department employee will unlock the curb stop and set the meter;
- The Developer/Contractor is responsible for the meter box and meter throughout the project. If the meter is found damaged, broken, frozen, out of the box, and/or if landscaping covers the meter box causing problems for the meter reader to read the meter, the meter will be locked off or pulled until the damages have been paid for and the problems have been corrected by the Developer/Contractor.

600 MATERIALS

All materials shall conform to the Madison County Water Department's current approved Specifications. Where feasible, approved manufacturers, models and part numbers are included. Any materials not specifically approved in these specifications can be used only if approved in writing by MCWD prior to order – not after receipt at the job site. Failure to obtain prior approval shall be sufficient cause for the Madison County Water Department Representative (MCWDR) to reject any materials so delivered to the Contractor. Water main materials shall be furnished by the Developer/Contractor unless otherwise approved or specified. Before installation, all materials shall be inspected and approved by a MCWDR.

All pipe, valves, fittings, and appurtenances shall be handled so as to prevent any damage whatsoever, particularly to the lining or coating. All pipe and fittings shall be loaded and unloaded by lifting so as to avoid shock or damage. Under no circumstances shall such materials be dumped, dropped or otherwise handled in a manner which may cause damage.

To ensure compliance with the *Reduction of Lead in Drinking Water Act*, effective January 2014, and to promote a smooth transition to the new lead content requirements, **all brass products that touch the wetted surfaces of the potable drinking water system must meet the “no-lead” condition as specified herein. All brass fittings must be Ford only.**

Contact Person: Coby Edwards at 256-532-1552

A. BALL CORPORATION VALVES

Approved Manufacturers

- Ford only

*** MUST USE NO-LEAD EQUIVALENTS OF THE APPROVED PRODUCTS**

Requirements:

- ALL BALL CORPORATION VALVES TO BE FULL PORT
- 2" BALL CORPORATION VALVES WITH TEE HEAD ADAPTERS

FB1600-4 1"CC x 1" Female IP
FB1100-TA- 7 (2")

B. CURB STOPS

Approved Manufacturers

- Ford only

*** MUST USE NO-LEAD EQUIVALENTS OF THE APPROVED PRODUCTS**

Requirements:

- MUST BE FULL PORT
- MUST BE SUPPLIED WITH LOCK WING

B63-342W - 1" Pack Joint PEP/IP x ¾" Meter Swivel

B63-444W - 1" Pack Joint PEP/IP x 1" Meter Swivel

- PACK JOINT FOR CTS x METER FLANGE WITH LOCK WING
BF43 -777W -2"

C. BACKFLOW DUAL CHECK VALVES

Approved Manufacturers/Models/Part Numbers *

- Watts
- Ames

¾" Dual Check Valve: 1" x ¾" 7 10 – U2 (WATTS)

1" Dual Check Valve: 1 ¼" x 1" 7 10 – U2 (WATTS)

3" and larger Dual Check Valve: 709 DCDA (WATTS) or 3,000 SS DCDA (AMES)

*** MUST USE NO-LEAD EQUIVALENTS OF THE APPROVED PRODUCTS**

Requirements:

- WATTS ONLY – ¾" and 1"
- WATTS OR AMES – 3" and larger

D. SERVICE SADDLES

Approved Manufacturers

- Ford
- Romac
- JCM
- McDonald
- Mueller

Requirements/Approved Part Numbers:

- DOUBLE STRAPPED WITH STAINLESS STEEL BANDS
- EPOXY COATED
- FORD OR EQUAL

6" x ¾" - FC202-669-CC3

6" x 1" - FC202-669-CC4

6" x ¾" or 1" (for A.C. & D.I.) - FC202-760-CC3 or CC4

- 6" x 2" - FC202-669-IP7
- 8" x ¾" or 1" - FC202-871-CC3 or CC4
- 8" x ¾" or 1" (for A.C. & D.I.) - FC202-979-CC3 or CC4
- 8" x 2" – FC202-IP7
- 10" x ¾" or 1" - FC202-1075-CC3 or CC4
- 12" x ¾" or 1" - FC202-1275-CC3 or CC4

E. STAINLESS STEEL TAPPING SLEEVES

Approved Manufacturers/Models/Part Numbers

- Ford FAST style
- Romac SST-FLG style
- JCM All Stainless 432
- Mueller

Requirements:

- FORD OR EQUAL - FAST TAP DESIGN
- FLANGE - STAINLESS, CARBON STEEL, OR DUCTILE
- TEST PLUG – BRASS
- MEET OR EXCEED ANSI/AWWA C223, LATEST REVISION

Stainless steel tapping sleeves shall be split type, and shall be constructed of 304 stainless steel with branch outlet flanges also of 304 stainless steel. All bolts and nuts shall be constructed of 304 stainless steel furnished with National Coarse threads and heavy hex nuts. All welded connections for the attachment of flanges, outlet sections and other component parts of the sleeve shall be fully passivated. The interior surfaces of the split sleeve shall be supplied with a full size gridded gasket which will surround 100% of the outer surface of the carrier pipe within the sleeve when installed. The gasket material shall be virgin SBR which meets or exceeds the requirements of ASTM D2000 (latest revision), virgin GPR which meets or exceeds the requirements of ASTM D2000 (latest revision), or other materials as approved. Flanged outlet gasket material shall be a minimum of 1/8" thick, cut full faced, and shall be composed of Buna-N rubber which meets or exceeds the requirements of ASTM D2000 (latest revision) or other materials as approved. All gasket materials shall be glued or otherwise bonded permanently to the stainless steel surfaces in sufficient areas to retain the gasket materials in proper alignment for installation. The nominal carrier pipe size (or range of sizes) and branch outlet size for which the tapping sleeve is designed shall be clearly and permanently marked on the side of each tapping sleeve.

F. TAPPING VALVES

Approved Manufacturers/Models/Part Numbers

- M & H Style
- Mueller
- American Darling

Requirements:

- NRS RESILIENT SEAT
- CLASS 250, 4”-12”
- EPOXY COATED

Non-Rising Stem (NRS) Resilient Seat Tapping valves shall be designed for a working pressure of 250 psi in accordance with ANSI/AWWA C515 standards, latest revision, and shall meet or exceed requirements for approval by Underwriters Laboratories Inc. and Factory Mutual Research Corporation. All tapping valves shall also meet or exceed the requirements of MCWD NRS Resilient Seat Tapping Valves Specification, latest revision. To eliminate the possibility of damage to the tapping valves caused from the use of full size shell cutters, the interior waterway of the valve body shall be designed with a full circular port opening having an inside diameter greater than or equal to the nominal pipe size. End configurations of all tapping valves shall be flanged inlet by mechanical joint outlet. **All flanged ends shall be provided with a raised alignment ring (centering ring or male pilot)** in accordance with MSS-SP60, shall be faced and drilled in accordance with ANSI/ASME B16.2 Class 150 and supplied complete with gaskets, bolts and nuts. Flange gasket material shall be 1/8" thick cloth inserted rubber, free from corrosive alkali or acid ingredients and suitable for use in potable water lines. Each gasket shall be supplied in one piece, cut full faced with adequate clearance between the gasket and the outside edge of the alignment ring, and supplied with the sufficient number and size holes to install the flange bolts. Mechanical joint ends shall conform to ANSI/AWWA C111/A21.11, latest revision. All tapping valves shall be equipped with 2" square operating nuts. Interior and exterior surfaces of the valve body shall be epoxy coated conforming to ANSI/AWWA C550, latest revision, having a minimum thickness of 10 mils and is certified to NSF Standard 61.

G. TRACER WIRE

#14 COPPER SOLID (INSULATED)

H. PLASTIC METER BOXES

Approved Manufacturers/Models/Part Numbers

Standard Meter Box: **DFW Plastics, Inc. – DFW37C-14-BODY**
(17x11x14 “C” Black Polymer Body)

Standard Meter Lid: **DFW Plastics, Inc. – DFW37C-1CF-LID**
(17x11 “C” Black CI Reader TR Knockout Polymer Deep Lid)

Meet the following minimum specifications:

- The meter box shall be made of a heavy-duty Polymer construction; a one-piece molded construction for durability.
- The meter box must have a minimum wall thickness of 0.55” and have been tested to withstand a minimum 15,000 lb. vertical load rating.
- All edges shall be clean and smooth for safety during handling.

- Inner and outer walls are to be smooth.
- The exterior shall be black to retard UV degradation.
- The meter box shall have a top flange, below the cover seat, to retard “push down” when set in paving and an anti-settling flange on the bottom.
- The cover shall be one-piece polymer construction, dimensions of 11” x 17”, with a CI reader lid.
- **Meter boxes and lids shall be delivered on pallets.**

I. MEGA LUGS FOR PVC

Approved Manufacturers/Models/Part Numbers

- EBAA Iron

3” – 2003	8” - 2008
6” – 2006	12”-2012

J. GATE VALVES

Approved Manufacturers/Models/Part Numbers

- Mueller A-2360 (MJ), A-2360-6 (FL)
- American Darling Series 2500
- M & H 7571

Requirements:

- NRS RESILIENT SEAT
- CLASS 250, 3” – 12”
- EPOXY COATED
- SHALL BE AMERICAN FLOW CONTROL’S SERIES 2500 DUCTILE IRON RESILIENT WEDGE GATE VALVE (or equal to)

Valves 2”-30” shall be resilient wedge type rated for 250 p.s.i.g. cold water working pressure. All ferrous components shall be ductile iron. Valves 4”-16” shall be in full compliance with AWWA C515, latest revision. The words “D.I.” or “Ductile Iron” shall be cast on the valve or stamped on a permanently attached corrosion resistant metal tag. The wedge shall be ductile iron encapsulated with nitrile rubber (2”-12” sizes”) or SBR rubber (14”-30” sizes). The wedge shall be symmetrical and seal equally well with flow in either direction. Valves shall be NSF Standard 61 certified. Bolting materials shall develop the physical strength requirements of ASTM A307 and may have either regular square or hexagonal heads with dimensions conforming to ANSI B18.2.1. Metric size, socket head cap screws therefore are not allowed. Operating nut shall be constructed of ductile iron and shall have four flats at stem connection to assure even input torque to the stem. All gaskets shall be pressure energized O-rings. Stem shall be sealed by three O-rings. The top two O-rings shall be replaceable with the valve fully open and while subject to full rated working pressure. O-rings set in a cartridge shall not be allowed. Valve shall have thrust washers located with (1) above and (1) below the thrust collar to assure trouble-free operation of the valve. All internal and

external surfaces of the valve body and bonnet shall have a fusion bonded epoxy coating, complying with ANSI/AWWA/ C550, latest revision, applied electrostatically prior to assembly.

Valves shall be American Flow Control's Series 2500 Ductile Iron Resilient Wedge Gate Valve (or equal to).

Unless specified otherwise in the purchase documents, valves that are to be used for above ground installation shall be equipped with hand wheels and flanged end connections. Valves that are to be used for below ground installations shall be equipped with 2" square operating nuts and mechanical joint end connections. Flanged end valves shall be faced and drilled in accordance with ANSI/ASME B16.2 Class 150, and shall be supplied with flange gaskets. Flange gasket material shall be 1/8" thick cloth inserted rubber, free from corrosive alkali or acid ingredients and suitable for use in potable water lines. Each gasket shall be in one piece, full faced with holes to pass bolts. Mechanical joint ends shall conform to ANSI/AWWA C111/A21.11, latest revision.

K. PVC WATER MAIN

Meet the following minimum specifications:

- SDR 21, CLASS 200
- Raw materials used in the manufacture of pipe must be in compliance with ASTM D1784, latest revision, and approved by National Sanitation Foundation (NSF).
- All pipe must bear the NSF seal for potable water and the manufacturer must be listed in the most current edition of NSF Standard 14 and 61.
- Pipe is to be manufactured from virgin compound designated PVC 1120 with a cell classification of 12454-8.
- All physical dimensions and tolerances shall comply with ASTM D2241 and NSF Standard 14, latest revisions.
- All pipes are to be white or blue in color.
- All identifying marks and in-plant testing must be in full compliance with ASTM D2241, latest revision.
- Pipe must have integral bell with a factory installed 'Rieber System' gasket as manufactured by Forsheda or S & B Technology.
- The manufacturer's production facility location shall be listed by NSF, insuring the bell of the pipe has been tested by NSF to satisfy the requirements of ASTM D3139, latest revision.
- **The pipe bell shall fully comply with ASTM D3139, Section 6.2 (Push-On Joints), latest revision.**
- Pipe lubricant furnished with pipe shall be compatible with potable water.

L. VALVE BOXES

All valves shall be equipped with valve boxes. Valve boxes shall be the heavy roadway type. The valve boxes shall be cast iron, two-piece screw-type with drop covers. The valve boxes shall be adjustable to 6" up or down from the nominal required cover over the pipe. Covers shall have

"Water Valve" or "Water" cast into them. Valve boxes shall be manufactured in the United States.

Under no circumstance shall DUCTILE IRON or PVC PIPE be used for a valve box or extension.

M. FIRE HYDRANTS

Approved Manufacturers / Models (or Part Numbers)

- Mueller Super Centurion 250 w/top stop nut
- American Darling B-84-B w/top stop nut
- M & H Model 129

Requirements:

- **FIRE HYDRANTS - 5 1/4" (bury depths 3'-8')**

POST HYDRANTS:

Approved Manufacturers / Models (or Part Numbers)

- Eclipse No.2 Post Hydrant
- M & H Style 33

Requirements:

- 3' Bury
- 3" MJ Shoe
- 2 1/2" NST port

Fire hydrants shall meet or exceed ANSI / AWWA C502 standards for dry barrel fire hydrants (latest revision), shall be listed by Underwriters Laboratories Inc. as meeting UL246 (latest revision), and shall be approved by Factory Mutual Research Corporation for a working pressure of at least 250 psi. Fire hydrants shall be equipped with two 2.5 inch bronze hose outlets and one 4.5 inch bronze pumper outlet connection. All bronze hose or pumper outlets shall be field replaceable shall be supplied with hose threads in conformance with the NFPA 1963 Standard for Screw Threads and Gaskets for Fire Hose Couplings. Threaded iron caps with gaskets shall be installed on all hose outlet connections to ensure that a tight drip proof seal can be obtained when needed. Each cap shall have a pentagonal national standard nut measuring 1.5 inches from point to flat for installation and removal and each cap shall be securely attached by chain to the hydrant barrel.

Fire Hydrant main valves shall be 5.25 inches in diameter, open left (counterclockwise), and shall be controlled by a pentagonal national standard operating nut measuring 1.5 inches from point to flat. The operating nut, valve rods, valve seats, and other working parts shall be capable of withstanding a minimum of 200 foot-pounds of input torque applied to the operating nut in either direction (closing or opening). A **travel stop** shall be provided on all main valve rods to ensure that no compressive forces can be applied to the valve rods when the operating nuts are rotated beyond the full open position. A weather cap, weather shield, or weather seal shall be provided

around the operating nut to ensure corrosion free operation under all weather conditions. All working parts shall be of a bronze to bronze design and all brass or bronze parts shall comply with the applicable ASTM or CDA alloy specifications. Upper valve rod threads shall be lifetime lubricated with an all temperature grease or oil which shall be sealed off from the internal waterway by multiple O-ring seals. All working parts such as the valve seat or stem shall be removable through the top of the hydrant without requiring the removal of the complete assembly from the line. Bronze multiport drain valve outlets (weep holes) shall be provided to drain water from the upper barrel once the main valve is closed and shall seal drip tight against rubber or plastic facings when the main valve is fully open.

Fire hydrant bonnets, barrels, shoes, and other ferrous parts shall be constructed of ductile iron which shall conform to one or more of the following specifications ANSI/AWWA C151/A21.51, ANSI/AWWA C110/A21.10, ASTM A395, or ASTM A536 latest revisions. Fire hydrant shoes shall be provided with a 6 inch mechanical joint inlet connection furnished without accessories and in conformance with ANSI/AWWA C111/A21.11 latest revision. The upper bolt holes of the mechanical joint inlet flange may be slotted to facilitate the installation of standard length tee-head bolts. Break away connections consisting of breakable flanges, pipe couplings, and or bolts shall be provided at ground level on the fire hydrant barrel and main valve stem. Main valve design shall open against system pressure so that system pressure will seal off the main valve in the event that the upper barrel or nozzle section is sheared off at the ground line flange. The bury depth shall be clearly marked on the outside of all fire hydrant barrels to ensure that break away flanges are installed at the proper height above ground.

Interior waterway surfaces of the fire hydrants below the main valve shall be epoxy coated conforming to AWWA C550 using an epoxy color other than black. All other surfaces with the exception of the working parts of the valve and the exterior surfaces of the hydrant barrel above the bury line shall be coated with an asphaltic varnish in conformance with Federal Spec. TT-V-51, or equal. Exterior surfaces of the fire hydrant above the bury line shall be painted with a rust resistant primer followed by a finish coating of **yellow enamel** in conformance with Federal Standard 595A. All fire hydrants shall be supplied with a manufacturer's limited warranty on materials and workmanship of at least 10 years duration.

Maintenance and repair manuals for each proposed device must be provided before the device can be approved. If any special tools are required to make repairs to the device, two sets of these tools shall be provided with the initial order for these devices.

Fire hydrants not meeting all the requirements of this specification, especially in regard to ductile iron, will be considered for acceptance. Each manufacturer shall state in writing which parts or features of their fire hydrant are not in conformance with the requirements of this specification. Preference shall be given to those hydrants meeting all requirements of this specification.

N. SERVICE TUBING

Approved Manufacturers/Models/Part Numbers

- Drisco Phillips 5100
- Endot Industries

- Silver Line

Meet the following minimum specifications:

- Service tubing is to meet or exceed 200 PSI working pressure, clearly marked on tubing.
- Tubing must comply with the latest revision of ANSI/AWWA C901, which applies to ½” through 3” sizes.
- One-inch (1”) service lines shall be PEP/SIDR7, Class 200.
- Two-inch (2”) service lines shall be CTS, Class 200.
- **Stainless steel insert stiffeners are to be used in all corporations and curb stops.**

O. ENCASEMENT PIPE FOR LONG SIDE SERVICES

2” or LARGER - SCH 40 OR CLASS 200

P. STEEL CASING PIPE FOR ROADWAY BORES

SIZES 12” – 42”

All utility encasement (casing) pipe shall comply with the appropriate requirements of ASTM A139 (latest revision), Grade B, for all sizes. Casing pipe shall be manufactured seamless or with a single straight linear fusion weld. No spiral welded casings will be accepted. All casing shall have a uniform diameter and circular cross section, with the maximum allowable variation of the diameter at the ends not to exceed 1/2 of the nominal wall thickness of the casing. All casing pipe shall be furnished in nominal lengths of 20 feet.

Minimum wall thickness shall be as specified in the following table and shall be measured at the thinnest point:

Diameter	Minimum Wall Thickness
less than 30 inches	0.250 " (1/4")
36" and greater	0.375" (3/8")

Mildly pitted pipe is acceptable provided minimum wall thickness is obtained at the deepest pits, the pipe is cleaned and coated with corrosion protective coating, and that such coating is clearly identified in the bid at time of submittal and is approved by the Engineer and/or MCWD. New unpitted pipe shall not require a corrosion protective coating. All ends shall be cut square and beveled for welding. All casing shall be clearly and legibly stamped, painted or otherwise permanently labeled on both ends with the following information:

- nominal diameter
- wall thickness
- exact length
- ASTM Specification

- pipe grade

Q. PRECAST CONCRETE VAULT

Meet the following minimum specifications:

- Size of vault must be approved by MCWD;
- Vault to be of adequate size for maintenance on meters, backflow preventers, etc;
- Vault walls and floor shall have a minimum thickness of 3 ½”;
- Vaults with 6” walls shall be reinforced with #5 rebar, additional reinforcing shall be utilized as specified by MCWDR or Engineer;
- Vaults shall be wet cast only, utilizing a steel form;
- Compression strength of the concrete must be rated at 4,000 psi after 28 days curing time;
- Cored or cast holes shall be utilized for inlet and outlet portals for piping and drainage;
- Steps, adjustable assembly supports, and additional portals shall be utilized as specified by MCWDR or Engineer;
- Vaults with 4” walls shall be constructed with 4,000 psi fiberglass reinforced concrete mix and 10 gauge wire cage with 3/8” rebar;
- 7’x3’ and 5’x3’ vaults, minimum wall thickness of 2”, shall be constructed with 4,000 psi fiberglass reinforced concrete mix and 10 gauge wire cage with 3/8” rebar.

R. ALUMINUM HATCH

Meet the following minimum specifications:

- All aluminum construction;
- Hydraulically assisted door opening for ease of operation;
- Corrosion resistant hinges and latches;
- Special designed channel frame construction for drainage;
- Reinforced trend plate lid.

S. FITTINGS

Approved Manufacturers/Models/Part Numbers

- American Cast Iron Pipe Company
- Tyler Pipe
- Union Foundry Company
- United States Pipe and Foundry Company

Requirements:

- FITTINGS: MECHANICAL-JOINT TYPE
- COATING: FUSION-BONDED EPOXY

Ductile iron fittings and accessories shall be supplied and delivered in the type, sizes and class as specified in the Contract Documents or shown on the drawings, and shall be manufactured in accordance with the following ANSI/AWWA specifications, latest revision, as well as other special requirements contained herein:

- C116/A21.16 "Protective Fusion-Bonded Epoxy Coatings for the Interior and Exterior Surfaces of Ductile-Iron and Gray-Iron Fittings"
- C110/A21.10 "Ductile-Iron and Gray-Iron Fittings"
- C111/A21.11 "Rubber-Gasket Joints for Ductile-Iron Pressure Pipe and Fittings"
- C115/A21.15 "Flanged Ductile-Iron Pipe with Ductile-Iron or Gray-Iron Threaded Flanges"
- C153/A21.53 "Ductile-Iron Compact Fittings"

All fittings shall be ductile iron (no cast iron), and shall be "Compact" (C153) style fittings wherever the size specified is available. Standard size fittings (C110) will only be accepted for those items which are not manufactured in the "Compact" style. All materials must be of domestic USA in origin, which shall be defined to include each component of every fitting, which must be cast, manufactured, and assembled, in its entirety, in the United States.

T. LOCATION TAPE

Meet the following minimum specifications:

- To be detectable marking tape, aluminum foil plastic encased;
- 5 Mil (2 Mil clear film laminated to aluminum foil, laminated to 2 Mil clear reverse printed);
- Solid color-coded bar with black letters;
- Installation instructions printed on tape;
- Meets or exceeds industry standards;
- Permanently printed;
- A.P.W.A. Uniform Color Code (Blue-Caution: Buried Water Line Below).

U. DUCTILE IRON PIPE

Approved Manufacturers/Models/Part Numbers

- American Cast Iron Pipe Company
 - Push-On: Fas-Tite (all sizes)
 - M. J.: Mechanical Joint (all sizes)
 - Restrained Joint: Lok-Ring (14" - 48"), Flex-Ring (4" - 12")
 - Ball Joint: Flex-Lok (all sizes)
- Clow Water Systems Corporation
 - Ball Joint: Clow Ball and Socket (all sizes)
- McWane Cast Iron Pipe Company
 - Push-On: Tyton (4" - 24"), Fas-Tite (30" - 36")
 - M. J.: Mechanical Joint (all sizes)

- Restrained Joint: Fastite Restrained Joint
- United States Pipe and Foundry Company
 - Push-On: Tyton (all sizes)
 - M. J.: Mechanical Joint (all sizes)
 - Restrained Joint: TR FLEX (all sizes)
 - Ball Joint: USIFLEX (all sizes)

Ductile iron pipe shall be supplied and delivered in the type, class and nominal diameters as specified in the Contract Documents or shown on the drawings, and shall be manufactured in accordance with the following ANSI/AWWA specifications, latest revision, as well as other special requirements contained herein:

- C150/A21.50 "Thickness Design of Ductile-Iron Pipe"
- C151/A21.51 "Ductile Iron Pipe, Centrifugally Cast"
- C111/A21.11 "Rubber-Gasket Joints for Ductile-Iron Pressure Pipe and Fittings"
- C104/A21.4 "Cement-Mortar Lining for Ductile-Iron Pipe and Fittings"

All ductile iron pipe shall be supplied *without the asphaltic seal coating*.

All pipe, 16" diameter or greater, shall be subjected to a hydrostatic pressure test equal to 75% of the minimum yield strength, where the minimum yield strength is 42,000 psi. Therefore, the required hydrostatic test should be equal to 31,500 psi in pipe wall, based upon outside diameter and total standard thickness. The Developer will require written certification that this testing has been successfully completed.

All pipe shall be supplied in nominal 18- or 20-foot sections unless otherwise specified and shall be push-on with gaskets and pipe lube. Each shipment of pipe shall contain a minimum of 50% "Field Gauge" pipe, unless otherwise specified at the time of placement of order. Madison County Water Department reserves the right to specify a larger or smaller percentage of "Field Gauge" pipe as required for particular projects or portions of projects. Particularly for pipe diameters above 12", the percentage required per shipment will normally be lower than 50%.

700 INSTALLATION

A. FIRE HYDRANTS *See Appendix Figure 1 and Figure 2*

Six-inch control valves shall be anchored directly to fire hydrant tees. Valves and valve boxes shall be installed as per specifications. Unless otherwise specified, hydrants may be connected to control valves with an anchoring assembly, or with mega lug retainer glands.

The Contractor shall furnish solid concrete blocks, 4" thick by 16" long, to be installed under the fire hydrant base. The hydrant shall be carefully placed on base block to prevent breaking and to hold hydrant plumb.

A minimum of four (4) cubic feet of washed gravel or crushed stone shall be placed around the base of all fire hydrants, to a point at least 12" above weep holes, in order to allow for proper drainage of hydrant barrel after closing. Gravel shall be installed a minimum distance of 12" in all directions from hydrant drainage holes. Pug mix will not be acceptable for this application. Additionally, all hydrants shall have caps on each nozzle, with chains tied together and secured to hydrant barrel to prevent loss of caps. All caps and threads shall be cleaned and greased by the Contractor.

All fire hydrants shall be located so as to provide complete and unobstructed access for a minimum of five (5) feet in all directions. Generally, unless otherwise shown on plans or unless otherwise directed or approved, fire hydrants shall be located at the intersection of right-of-way and property lines. In subdivisions where electric transformers or power poles are to be placed on the same lot line as fire hydrants, fire hydrants may be offset two (2) feet from lot line in one direction, with transformer offset two (2) feet in other direction. No fire hydrants are to be placed in sidewalks. Place hydrants a minimum of three (3) feet from sidewalk. The pumper nozzle shall be facing the street and shall be no less than 18" but nor more than 24" from final ground elevation. The safety flange shall be approximately 2-3 inches above finished ground level to provide access to bolts and nuts.

Hydrant extensions, where required, shall be installed by the Contractor and considered incidental to fire hydrant installation. Contractors are encouraged to request taller or shorter hydrants before installation to avoid delays and extra work involved with addition of extensions. Where hydrant risers are required, the Contractor shall inform himself of the type of hydrant riser to be used and its proper installation, taking special precaution to insure the breakaway flange of the riser is installed next to the hydrant barrel and not below grade.

The Contractor shall check each fire hydrant installation with a level to insure it is installed plumb. Any fire hydrants improperly located, not plumb, or improperly installed and backfilled shall be removed and properly reinstalled at the Contractor's expense. **All fire hydrants shall be installed a minimum of 750 feet apart.**

Fire hydrants with any paint damage shall be touched up with yellow enamel - Safety Yellow (Pre-Mixed), Sherwin-Williams paint number B54Y37.

B. SERVICE LINES AND METER BOXES *See Appendix Figure 3*

Standard residential and commercial installations shall include the following materials listed below.

- Service Saddle - epoxy coated with double stainless steel bands
- Ball Corporation Valve (with pack nut) – FULL PORT
- Curb Stop (pack joint by meter swivel) – FULL PORT
- Plastic Meter Box
- Service Tubing – 1” PEP/SIDR7; 2” CTS
- Stainless Steel Insert Stiffeners
- Encasement Pipe – 2” or larger for long side services
- Tracer Wire – on all service lines

Service lines shall be installed perpendicular to mains using the shortest possible route. Tracer wire shall be installed above pipe for the entire length of service. All service lines shall be continuous; **no splices** will be allowed. In a case where the service line is damaged or must be extended during construction, the entire service line must be replaced.

Service lines shall not be installed under driveways or placed where known future driveways will be installed. In the event a service tap ends up under a driveway, the cost to move will be with the Owner/Developer of the subdivision regardless of the situation.

When two service lines are placed in the same earth trench, a minimum of at least one foot spacing between each service line is required. There is to be no more than two (2) taps at one location, and these service lines must run in the same direction.

For long side services, encasement pipe shall run from corporation to curb stop. A gap of 1 to 2 feet shall be left from each end to allow for access to the corporation and curb stop. Encasement under roadways shall have a minimum cover of 18”. Road crossings are to be backfilled with granular materials.

For developments with open ditches, install meter boxes one (1) foot behind U & D Easement; for curb and gutter - 12’ back of curb. Meter boxes are to be left 3” above final grade and/or 6” above top of curb.

Curb stops are to stop just inside of meter box with operating nut on curb stops turned up. Curb stops shall be installed, horizontally and straight with meter box, through the cut out opening provided in the meter box. *See Appendix Figure 3*

Meter boxes that get covered or lost, because of landscaping or other means, will be found by Developer/Contractor at his expense and brought back to proper grade before MCWD will install a new meter. In the event Developer/Contractor is unable to find meter box, the cost for a new service line and meter box will be borne by Developer/Contractor. In no way will the expiration of the warranty period allow the Owner/Developer of said subdivision to be exempt.

All taps shall be left open until successful completion of pressure test unless otherwise approved, but in no case shall taps be backfilled until visually inspected by MCWDR. Should this requirement

be ignored, the Contractor will be required to uncover taps for inspection prior to beginning of pressure test.

Special care should be taken when backfilling under mains and corporation valves to insure there are no voids. Select fill material shall be added in 3 to 6 inch layers under the corporation valve, and tamped, to a point 12 inches above the corporation valve to support the service line and insure no settling will occur causing a binding pressure were the service line is connected to the corporation valve. Once this is accomplished, backfill may be deposited by front end loader, bulldozer or other suitable equipment.

C. DEWATERING TRENCHES

Dewater excavation continuously to maintain a water level two (2) feet below the bottom of the trench. Dewater running sand by well pointing. Where soil conditions do not permit use of well point, construct French drains of crushed stone or gravel to conduct water to pumps.

D. TRENCH STABILIZATION

Wherever the material at the bottom of the trench is unsuitable for the proper installation of the pipe, the MCWDR will direct the removal and replacement of the unsuitable material. The Contractor shall prepare the trench bottom to support the pipe uniformly throughout its length. If the trench bottom is spongy, or if the trench bottom does not provide firm, stable footing, the trench will be determined to be unable to support the pipe, inadequately prepared, and inadequately dewatered. When such a trench condition exists, the Contractor shall dewater the trench to adequately prepare a trench bottom which will support the pipe.

E. LAYING PIPE IN TRENCHES, ALONG ROADS, EASEMENTS

See Appendix Figures 4 through 12

- **Inspection:** No water mains shall be covered until visually inspected by MCWDR. Any mains covered prior to inspection shall be uncovered, at the Contractor's expense.
- **Earth Trenches:** Grade the bottom of the trench to a true line. Lay the pipe in clean bedding material, free of rock, organic, and other unsuitable materials. *See Appendix Figure 4*
- **Rock Trenches:** Bed the pipe in at least 6 inches of clay or granular bedding material. Backfill with the same material to at least 2 feet above the pipe. *See Appendix Figure 5*
- **Drainage Crossings – ditches/streams/rivers:** Ductile iron shall be laid under bottom of drainage ditch/stream/river and concrete poured on pipe, unless otherwise specified. *See Appendix Figures 6, 7 or 8*
- **Drainage Crossings – pipes/culverts:** When crossing under drainage pipe, ductile iron pipe should be laid a minimum of 18" under the drainage pipe. No fittings or taps shall be placed under drainage pipes.
- **Along Roads:** Water lines are to be laid behind existing ditches or future drainage ditches, close to right-of-way line. For open ditches, the center line of water main should be 1' inside

ROW. For curb and gutter with 50' ROW, the center line of water main should be 9' back of curb. Where there is curb and gutter and sidewalks, water main is to be laid between sidewalk and right-of-way line. Keep a distance of 2 feet from sidewalk, at a minimum.

- **Laying Water Lines Inside Subdivisions:** Before laying water mains in subdivisions, roadways are to be brought to sub-grade to determine proper grade depth for new water main. Right-of-way lines should be staked to determine the center line of new water main.
- **Power Cables:** No underground (primary or secondary) cables shall be laid in the same trench with water mains. Water mains will be placed on the opposite side of right-of-ways, away from all underground primary cables.
- **Tracer Wire:** All PVC pipe shall have tracer wire #14 solid copper (insulated). Tracer wire is to be brought up on outside of valve boxes and placed 12" above center of PVC pipe.
- **Dead End Mains:** Dead end mains are to be anchored using one full joint of ductile iron pipe with concrete and restrainer gland. *See Appendix Figures 9-11*
- **Fittings and Valves:** No valves are allowed in pavement. Coating is to be fusion-bonded epoxy color red oxide; fittings and valves are to be mechanical-joint type. Mega lugs are to be used on all mechanical joints, as a way of fastening the connection. Concrete thrust blocking will be required in addition to mega lugs except on fire hydrant tees. When starting off with a full joint of PVC pipe, always cut off bevel end of PVC pipe for a better fitting mechanical joint.
- **Open Cut Roads:** Ductile iron pipe is to be used on all roadway crossings, including new roads and existing roads. *See Appendix Figure 12*
- **Depth of Cover:** All water mains shall have a minimum cover of 30 inches. Unless installed under storm drains, no water mains shall exceed a maximum cover of 54 inches measured from final grade. Service lines shall have a minimum cover of 18 inches.
- **Protection of Pipe:** Contractor shall exercise care in keeping foreign materials out of main before and during installation. Should this requirement not be adhered to, pipe shall be removed, cleaned and replaced, or pipe shall be cleaned by running a series of polyfoam pigs through the pipe line at the Contractor's expense. At the end of each day's work, all open ends of piping shall be sealed with plugs so designed as to prevent any foreign matter from entering the pipe. Plywood barriers are not acceptable for this purpose.
- **Joint Deflection:** Pipelines intended and/or shown to be laid in a straight line shall be laid straight with no deflection at the joints. No deflection will be allowed unless necessary due to grade, curves or to avoid obstructions. Should it be necessary to deflect pipe from a straight line, the maximum amount of deflection allowed shall not exceed the values listed in the following table or as recommended by the manufacturer.

PIPE SIZE	MAX. JOINT DEFLECTION	MAX. DEFLECTION PER JOINT
3" - 6"	5°	21" (20' JOINTS)
8" - 12"	5°	19" (18' JOINTS)

14" – 16"	4°	15" (18' JOINTS)
18" - 36"	3°	11" (18' JOINTS)

F. THRUST RESTRAINT *See Appendix Figures 11, 13 and 17*

All tees, plugs, caps, bends, reducers or any other locations where unbalanced forces exist shall be anchored by adequate thrust blocking as defined herein. Concrete for thrust blocking shall be Class B concrete (3,000 PSI) and shall be placed against undisturbed earth. SAKRETE is not acceptable for thrust blocking. A minimum of one-third (1/3) cubic yard of concrete for each thrust block shall be used. Where weak soil conditions or higher test pressures are encountered, the bearing area of each block will be increased as required by the Engineer or MCWDR.

The Contractor shall insure that all bolts, nuts and set screw rings are left clear of concrete thrust blocking for future access. Plywood or other suitable means of confining the concrete and keeping the bolts and nuts clear shall be used, and any excess concrete shall be removed at the Contractor's expense.

Vertical bends, at locations where the installation of concrete thrust blocks is difficult, shall be secured by the use of MEGA LUG retainer glands and/or THREADED RODS and a minimum of 100' ductile iron pipe restrained by locking gaskets.

Thrust ties may be required in some instances by the MCWDR or Engineer. Where so required, the Contractor shall provide threaded rods, mild steel (A-36) or equivalent, with a minimum diameter of 3/4 inch. Threaded rods shall be installed using approved harness assembly or special bolts or plates so designed for this purpose.

Minimum number of threaded rods shall be as follows:

<u>PIPE DIAMETER</u>	<u>TIE RODS REQUIRED</u>
4" TO 10"	2
12" TO 14"	4
16" TO 20"	6
24"	8
36"	12 (1")

Following installation, threaded rods and nuts shall be coated with coal-tar epoxy paint for protection from rust and corrosion.

G. TAPPING EXISTING WATER MAINS *See Appendix Figure 14*

All 6" and larger taps shall be made by MCWD with a **minimum notice of forty-eight (48) hours.**

The Contractor shall do all excavation and furnish and install the tapping sleeve and valve in accordance with the specifications. In addition, the Contractor shall do a pressure test on the tapping sleeve and valve prior to MCWD tapping the water main.

H. VALVE BOXES *See Appendix Figure 15*

Valve boxes shall be set vertical and concentric with valve stem. Backfill and compact area around valve body with gravel or other suitable and approved granular material before setting valve box so that valve box does not rest directly on valve body or pipeline. Backfill around valve boxes shall be the same as that specified for adjacent pipe and shall be carefully and thoroughly compacted. Care should be taken to insure that the valve box is not displaced from proper alignment or grade. Misaligned valve boxes shall be excavated, plumbed and backfilled at the Contractor's expense.

Under no circumstance shall DUCTILE IRON or PVC PIPE be used for a valve box or extension.

Valve boxes must be brought to proper grade by ordering the proper height valve box or by the use of a valve box screw-on-extension.

When setting valve boxes in subdivisions with curb and gutter, the top grade of the valve boxes shall be 6", minimum, above top of curb.

Any valves installed at a depth greater than 48" (measured from final grade to top of valve operating nut) shall have a valve stem riser installed prior to backfill at the Contractor's expense. The stem riser shall extend to a depth of one foot below final grade.

All valve boxes shall be constructed with concrete pads, two-foot square by 4" thick concrete class B, or a 24-inch round valve box pad.

800 JACKING AND BORING ROADWAYS

See Appendix Figure 16

This section of the specifications shall cover the installation of encasement pipe and/or carrier pipe under existing streets, roads, highways, or other areas as may be designated on the plans or described herein. Unless otherwise noted, the work shall include all excavation and backfill incidental to the installation.

The Developer/Engineer shall obtain all necessary permits for any under-crossings, but the Contractor shall be responsible for insuring that all crossings are installed in accordance with the requirements of the governing authority. The Contractor shall also be responsible for obtaining and posting, with the MCWD or the Developer/Engineer, any and all insurance and/or surety required by, and acceptable to, the governing authority.

The Contractor shall coordinate all operations with both MCWD and the governing authority. All required labor, materials and equipment shall be on the site prior to the start of construction. All authorities shall be notified at least 48 hours in advance of intent to begin construction operations within their right-of-way, except for when working within railroad right-of-ways which normally requires ten (10) days advance written permission. During construction operations, barricades and lights to safeguard traffic and pedestrians shall be furnished and maintained until such time as the backfill has been completed, and then shall be removed from the site.

Copies of all under crossing permits obtained by the Developer/Engineer shall be kept available for ready reference at the job site by the Contractor in accordance with individual permit requirements.

Tentative limits for under-crossings are shown on the plans. Lengths may be increased or decreased as the conditions warrant.

Suitable pits or trenches shall be excavated for the purpose of conducting the boring or jacking operations and for placing the joints of pipe. This excavation shall not be carried to a greater depth than is required for placing the guide rails and/or jacking timbers and shall not be placed nearer to the roadbed than the minimum distance specified by the governing authority. An approach trench shall be excavated accurately to grade at the opposite end of the proposed casing pipe.

All open trenches shall be cut back or adequately braced and shored in such a manner to prevent caving or sliding of the walls into the open pit or trench.

The drilling of pilot holes for pipe alignment prior to installation by jacking, boring or tunneling will not be required, but may be necessary in order to maintain proper grade.

The Contractor shall take the proper precautions to avoid excavating earth or rock beyond the limits of excavation needed to install the casing pipe. Bored installations shall have a hole diameter not exceeding the casing outside diameter by more than one inch. Should excessive voids or too large a bored hole occur for any reason, remedial measures shall be approved by the Engineer and undertaken by the Contractor. Such remedial measures will, in most instances, require the grouting

of voids.

All casing pipe shall be continuously welded at joints for a rigid and watertight encasement. Each end of the casing, to be joined by welding, shall be cut square and shall have a circular cross section without deformities. Casing shall be aligned and joined to ensure the interior surface of the welded joint inside the casing is smooth with no projections, which might interfere with or prevent the installation or removal of the carrier pipe within the casing.

All boring and/or jacking machines shall be suitable for the size of casing required, and shall be so designed as to apply pressure uniformly around the ring of the pipe. Any pipe damaged in jacking operations shall be repaired or replaced by the Contractor at his expense.

Once boring and/or jacking operations are underway, the work shall be carried on without interruption, insofar as practicable, to prevent the pipe from becoming firmly set in the embankment.

When boring operations have been completed, ends of the casing pipe shall be suitably plugged and marked, and all pits shall be backfilled. No pits shall be left unattended or open for any length of time following completion of boring operations without written approval from the Engineer and/or MCWDR. This requirement may be waived should the Contractor install carrier pipe directly following the completion of boring operations.

WATER MAINS (Carrier Pipe) shall be ductile iron the full length of said bore. The transition back to PVC shall be made with a ductile iron sleeve and mega lugs.

Mega lugs and locking ductile iron gaskets shall be used when installing a **BACK TAP**, with fittings, to existing water mains. Concrete kickers will be required in addition to mega lugs and locking gaskets.

900 PRESSURE TESTING REQUIREMENTS

A. GENERAL

As soon as a continuous valve section of new water main has been installed, the Contractor shall proceed immediately to complete flushing and pressure testing as specified herein. However, no pressure test shall be conducted until all taps, including service taps, have been installed and all thrust blocking has been in place for a minimum of five days.

The Contractor shall furnish all labor, materials, tools and equipment necessary to fill and flush the lines and then seal the main for testing. The pipe shall be slowly filled with water and all air expelled from the pipe. The pipe shall then be allowed to stand for 24 hours, after which it shall again be checked for any trapped air. All new lines shall be flushed, until clear water is observed, at a minimum velocity of 2.5 feet per second. It shall be the responsibility of the Contractor to provide adequate disposal of flushed water and to protect existing structures or landscaping from damage from flushing operations. All mains shall be flushed with a full sized flushing assembly unless otherwise approved.

All pressure tests shall be scheduled at least 24 hours in advance and shall be conducted in the presence of the MCWDR. No pressure test shall start at a time which will result in the completion time being later than 3:00 p.m. **The duration of each pressure test shall be a minimum of 2 hours for uncovered pipes and 6 hours for pipelines which have been backfilled.** A pipe that is partially backfilled will be considered backfilled. All valves within the section being tested shall be open during the pressure test, including fire hydrant control valves. The test pressure shall be the **greatest** value of the following:

- 1.5 times the operating pressure
- 160 psi

MCWD will furnish a digital pressure gauge for recording each pressure test; however, the Contractor shall furnish a gauge for monitoring the pressures during informal pressure tests, as the MCWD gauge is only to be used for formal pressure tests. The Contractor shall provide a meter capable of measuring low flows so that the amount of water required to maintain test pressure may be accurately measured, as described in Section B.(ii), below.

B. TESTING PROCEDURES

The following testing procedure shall be used:

- (i) Pump line to required test pressure and record gauge pressure.
- (ii) Monitor gauge continuously and record pressure every 30 minutes. If, at any time during the pressure test, the pressure drops more than 5 psi, pump back to test pressure and record amount of water required restoring the tested section to initial test pressure. If the pressure drops more than 5 psi, more than 3 times during the testing period, the test is considered a fail. The Contractor shall investigate the pressure loss and re-test.

- (iii) Continue until completion of required test period; then total the amount of water used to maintain pressure within 5 psi of required test pressure. This amount shall be defined as leakage.

C. ALLOWABLE LEAKAGE

Allowable leakage shall be defined by using the formula below. Any leakage greater than the calculated allowable leakage for a test section shall constitute a failing test and will require the Contractor to find and eliminate the leak(s). In addition, any observed leaks shall result in a failed test and require fixing and re-testing. All costs associated with finding and repairing leaks on the new main shall be borne by the Contractor.

The following formula may be used to calculate the allowable leakage:

$$L = \frac{SD\sqrt{P}}{148,000}$$

L = Allowable leakage in gallons per hour
S = Length of pipeline in feet
D = Nominal diameter in inches
P = Average test pressure during test in psig

Generally, short valve sections shall be tested independently, but the Contractor may request that several sections be combined on complex projects involving small diameter mains in short sections. In this case, the allowable leakage for each section shall be computed separately; the smallest value obtained shall be used for the entire test section, in order to eliminate the possibility of a major leak at a single location. All mains 10" diameter or larger shall require a passing pressure test on each individual valve section.

1000 DISINFECTION AND SAMPLING

A. GENERAL

Following acceptable completion of the pressure test, water mains shall be disinfected, by the Contractor, in accordance with AWWA specifications governing water main disinfections. Bacteriological samples shall be collected from each dead end main, every 1,200 feet, and as directed by the MCWDR.

The Contractor shall provide an adequate number of temporary taps, usually 1", for the injection of a disinfecting agent, collecting bacteriological samples, and pressure testing, as shown on the project drawing. At a minimum, disinfection taps are required at each tie point, and sampling taps are required at a minimum of 2 feet from each dead end main and along each valved section of main. Following successful disinfection and sampling, the Contractor shall remove all materials and cap all temporary corporation stops. The cost of all materials, equipment, and labor to perform testing per the specifications shall be borne by the Contractor.

The Contractor may be required to install temporary blow-offs at ends of all mains, as directed by the MCWDR, and must remove these installations upon successful disinfection of mains. The Contractor shall properly dispose of flushing water and protect any structures, subgrade or landscaping as required. The Contractor shall obtain and apply sufficient quantities of a reducing agent to thoroughly neutralize the remaining chlorine residual. The quantities and types of neutralizing chemicals to be used shall be in accordance with AWWA C651, latest revision, and shall conform to all Federal, State, and local regulatory requirements.

Madison County personnel will collect the samples for bacteriological testing. Should any main's test yield failing results or deviate from the specifications, more samples must be taken. The Contractor will be responsible for re-disinfecting the main(s). MCWDR will then resample the main(s). Should failed samples again be collected after two tries to disinfect, it shall be assumed that there is a problem with the main(s), and the Contractor shall be required to determine the cause of the problem. The Contractor may at any point, when trying to obtain satisfactory results from a main which has repeatedly failed health samples, attempt to disinfect mains and hire an independent, approved laboratory to collect and analyze samples at his own expense, under the supervision of MCWD.

B. DISINFECTION METHOD

The Contractor shall disinfect the water mains in accordance with the most recent AWWA specifications, using the continuous-feed method. ANSI/AWWA C651-05 is the reference for the procedure below, which is to be used for disinfecting all water mains:

- (i) **Preliminary Flushing.** Before the main is chlorinated, it shall be filled to eliminate air pockets and flushed to remove particulates. The flushing velocity shall not be less than

2.5 ft/sec. (Flushing is not a substitute for using preventative measures during construction. For 24-inch diameter mains, an acceptable alternative to flushing is to broom-sweep the main.)

- (ii) **Chlorinating the Main.** Water supplied from a temporary backflow-protected connection to the existing distribution system shall flow at a constant and measured rate into the newly installed main. In the absence of a meter, the rate may be approximated using a Pitot gauge in the discharge, measuring the time to fill a container. At a point no more than 10 feet downstream from the beginning of the new main, water entering the new main shall receive a dose of chlorine fed at a constant rate such that the water will not have less than 50 mg/L of free chlorine. To ensure that this concentration is provided, measure the chlorine concentration at regular intervals in accordance with the procedures described in the most current edition of *Standard Methods for the Examination of Water and Wastewater* or AWWA Manual M12, or using appropriate chlorine test kits. Chlorine application shall not cease until the entire main is filled with heavily chlorinated water. The heavily chlorinated water shall be retained in the main for at least 24 hours. After 24 hours, the treated water in all sections of the main shall have a free chlorine residual no less than 10 mg/L. The Contractor must either document the free chlorine residual and provide the documentation to the MCWDR or test the free chlorine residual in the presence of the MCWDR.

The Contractor shall then flush the main until the chlorine concentration in all sections of the main equals the chlorine concentration of the supply water in the distribution system. After the water remains in the main for 24 hours, the water department will then obtain samples for bacteriological examination.

Direct-feed chlorinators shall not be used for the application of liquid chlorine. The preferred equipment for applying liquid chlorine is a solution-feed vacuum operated chlorinator and a booster pump. Feed lines shall be made of suitable material to withstand corrosion caused by the chlorine and high pressures created by the booster pumps.

C. SAMPLING

Samples can be taken on Monday through Thursday before 1 PM. The Contractor must provide three work-days notice to have a sample taken. The sample results will be provided to the Contractor within two work-days of the sample being taken. Madison County will not take or read samples on the weekends. If the sample results are not satisfactory, then the Contractor will be required to re-disinfect the main and schedule another bacteria sample. This re-disinfection and sampling will continue until the bacterial sample results are satisfactory.

1100 APPENDIX – DETAILED DRAWINGS

Figure 1 – Fire Hydrant Installation.....33
Figure 2 – Post Hydrant Detail34
Figure 3 – Service Line Installation.....35
Figure 4 – Earth Excavation for PVC and Ductile Iron.....36
Figure 5 – Rock Excavation for PVC and Ductile Iron.....37
Figure 6 – Ditch and Obstruction Crossing Detail.....38
Figure 7 – Concrete Encasement for Creek and Ditch Crossing Detail39
Figure 8 – Creek and River Crossing Detail.....40
Figure 9 – Blow Off Detail41
Figure 10 – Blow Off Detail Using Fire Hydrant42
Figure 11 – Dead End Anchor Block Detail.....43
Figure 12 – Water Main Trench Details44
Figure 13 – Concrete Thrust Block Detail.....45
Figure 14 – Tapping Sleeve and Valve Detail46
Figure 15 – Valve Box Detail47
Figure 16 – Roadway Boring Detail48
Figure 17 – Anchor Block for Reducer Detail.....49

PRV Figure – Pressure Reducing Valve and Vault50

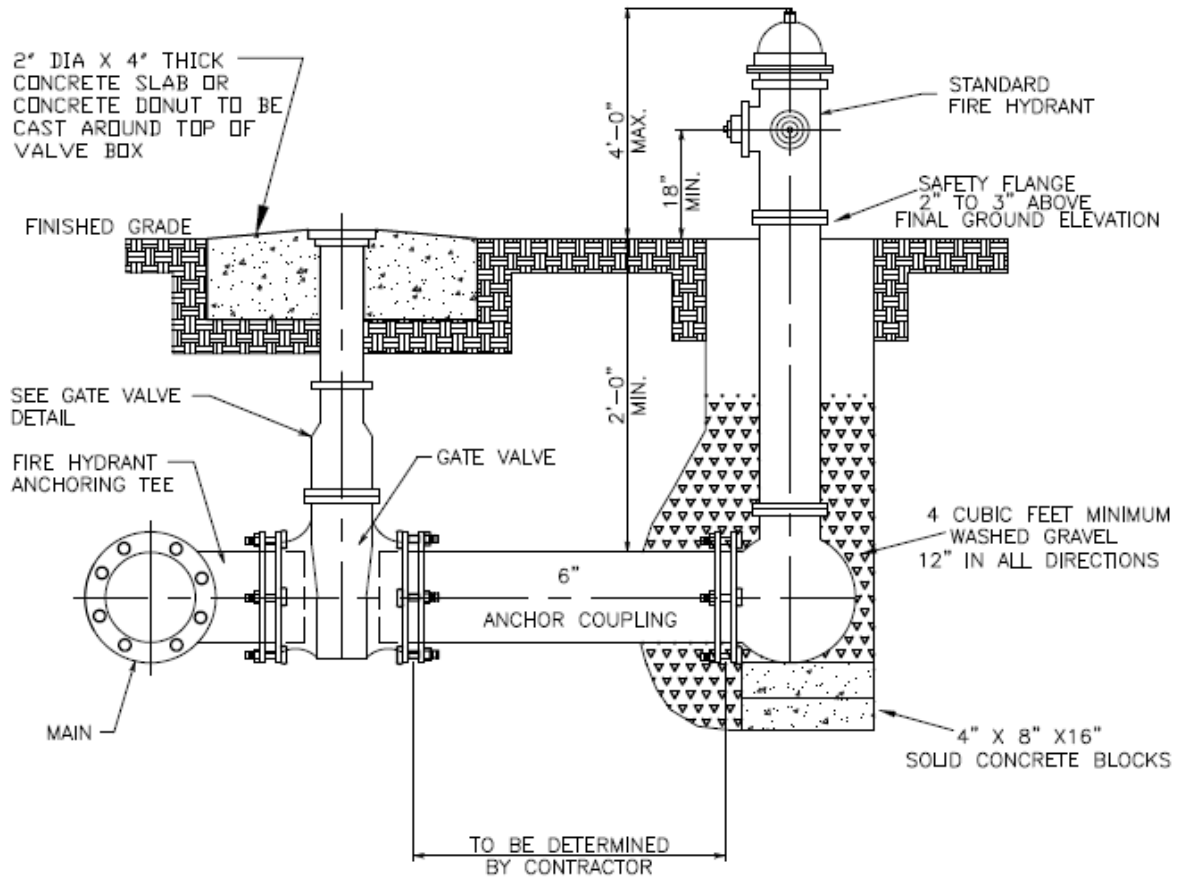

Scar or Paint Damage Hydrants
TO BE RECOATED USING PAINT BRUSH
Safety Yellow enamel
(Pre-Mixed) b54y37

FIRE HYDRANT DETAIL

NOT TO SCALE

Figure 1 – Fire Hydrant Installation

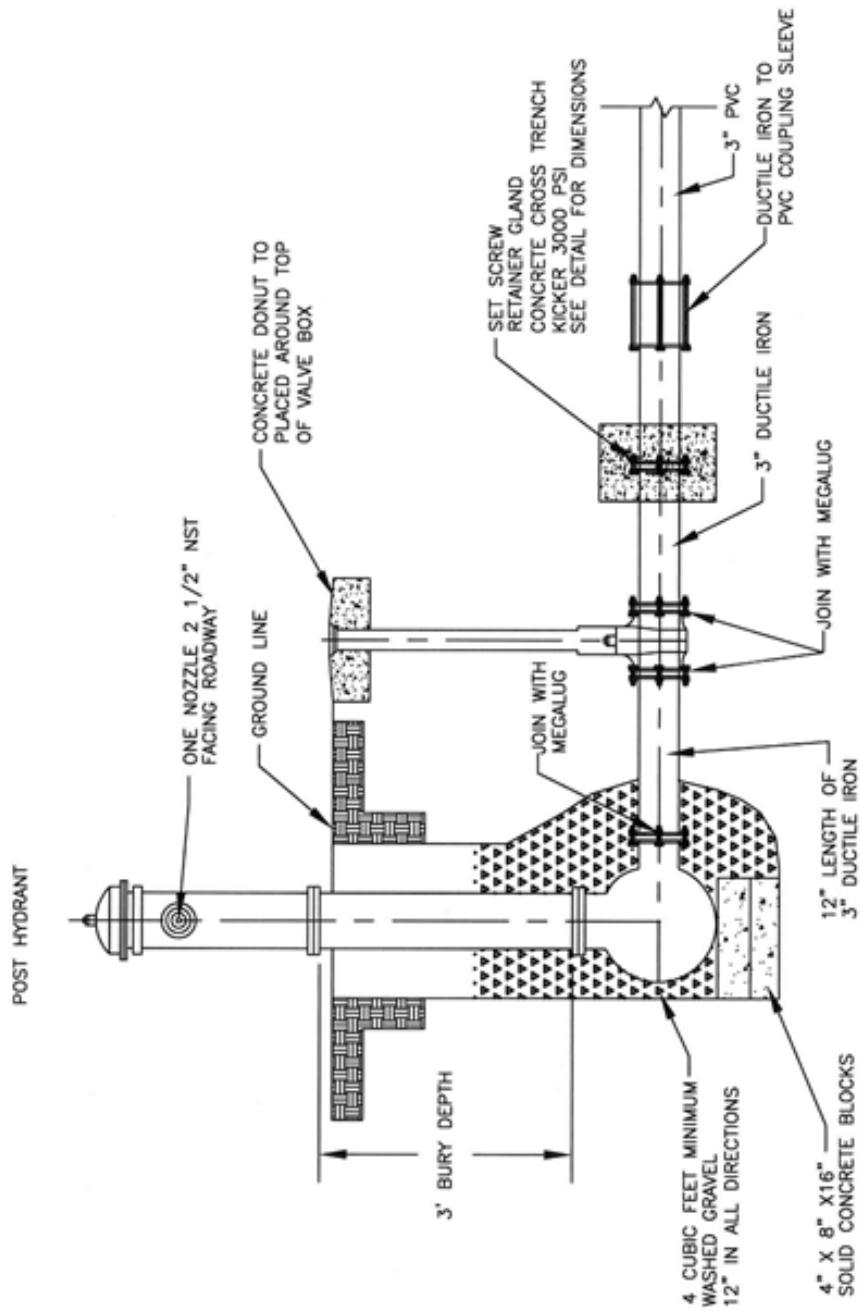

POST HYDRANT DETAIL
 NOT TO SCALE

Figure 2- Post Hydrant

Carson Plastics or Equal

Plastic Meter Box: MSBCF-1730-18
 Lid For Plastic Box: MSBCF-1730-R

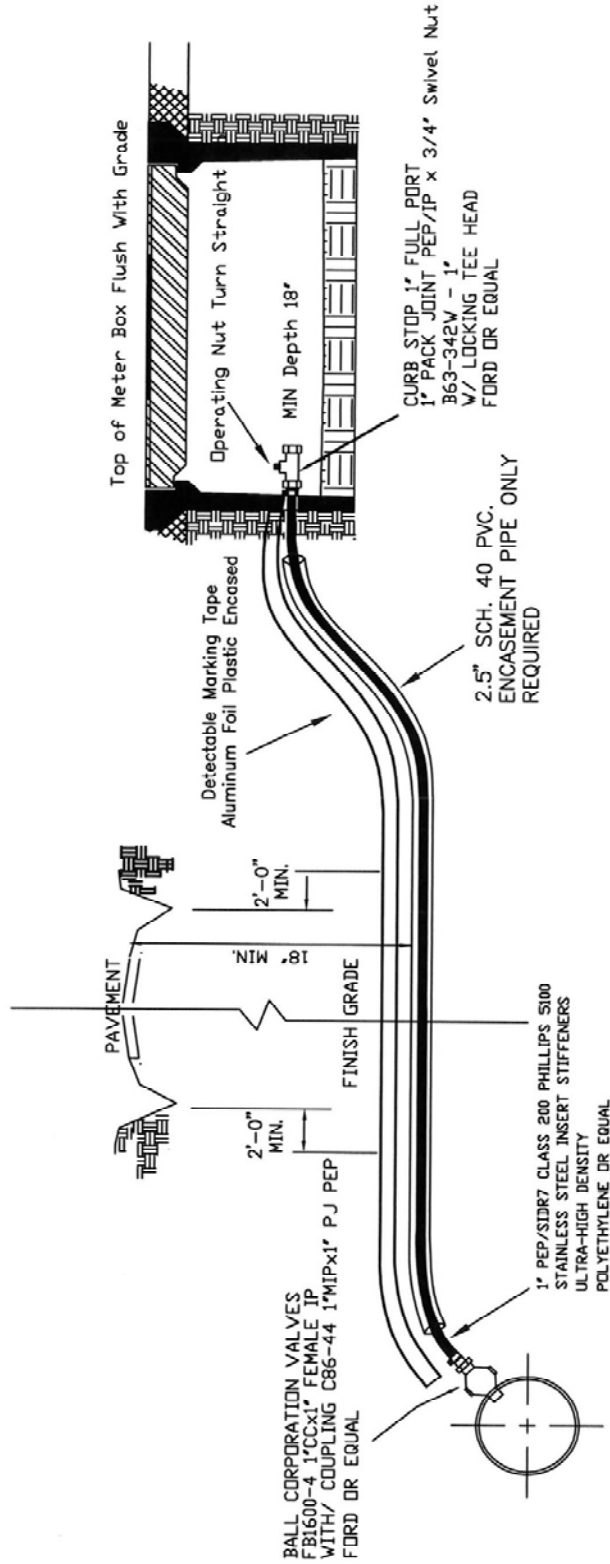

1" SERVICE ASSEMBLY

NOT TO SCALE

Figure 3 - Service Line Installation

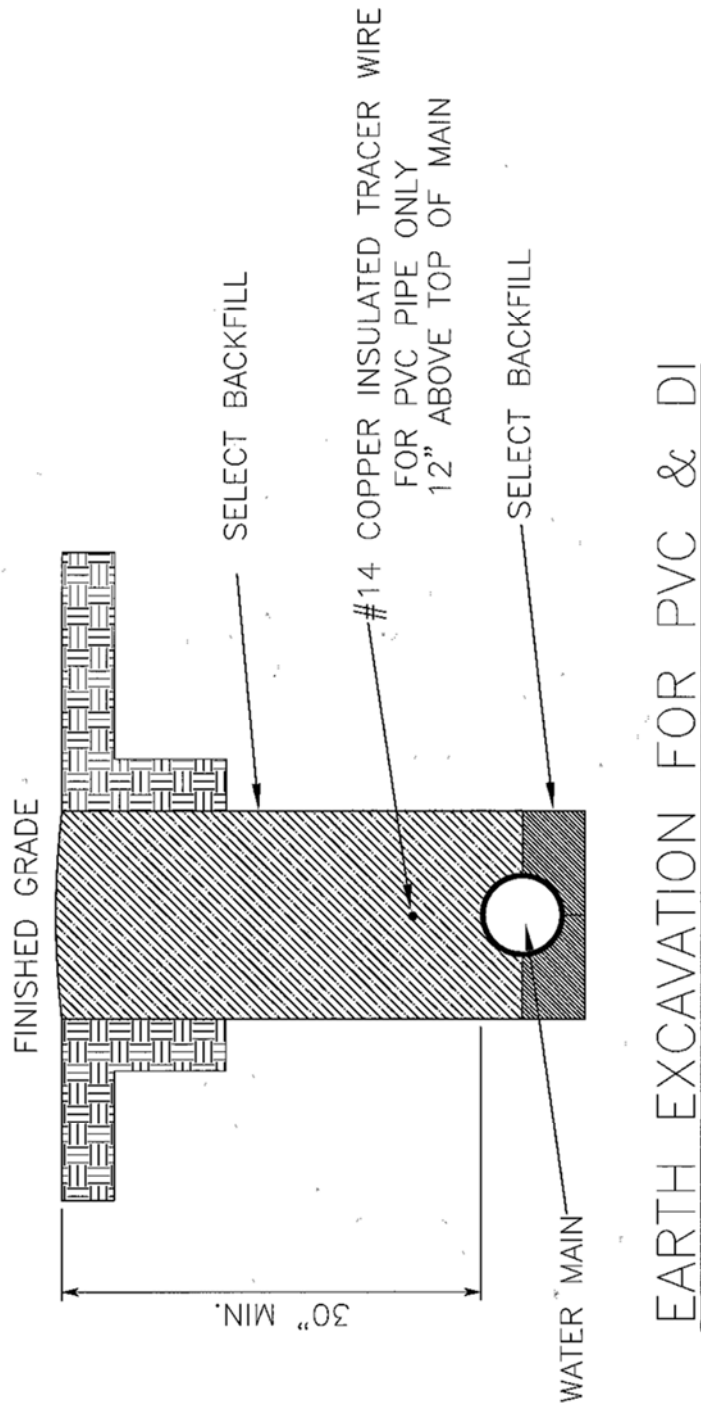
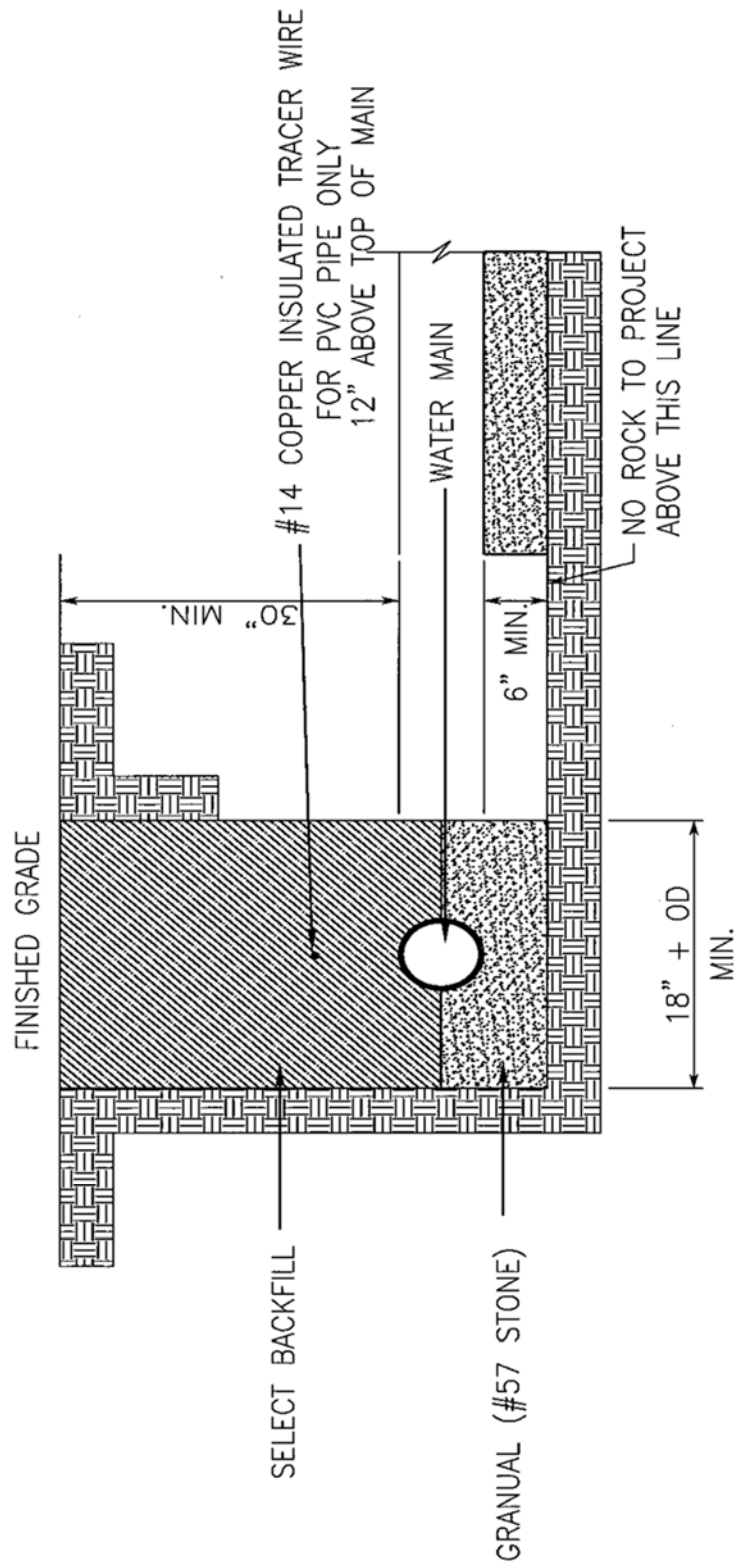

Figure 4 - Earth Excavation for PVC and Ductile Iron



ROCK EXCAVATION FOR PVC & DI

Figure 5 – Rock Excavation for PVC and Ductile Iron

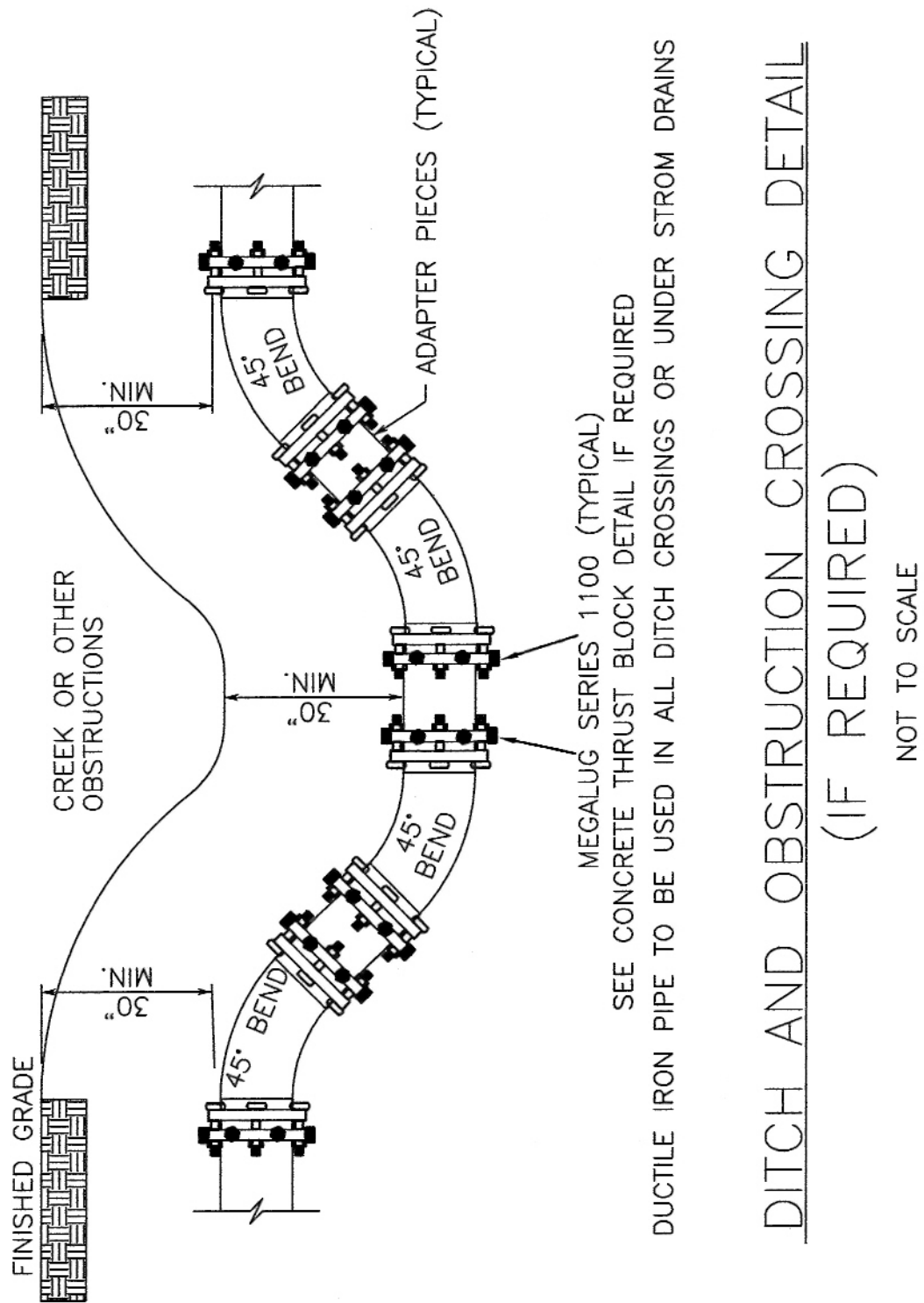
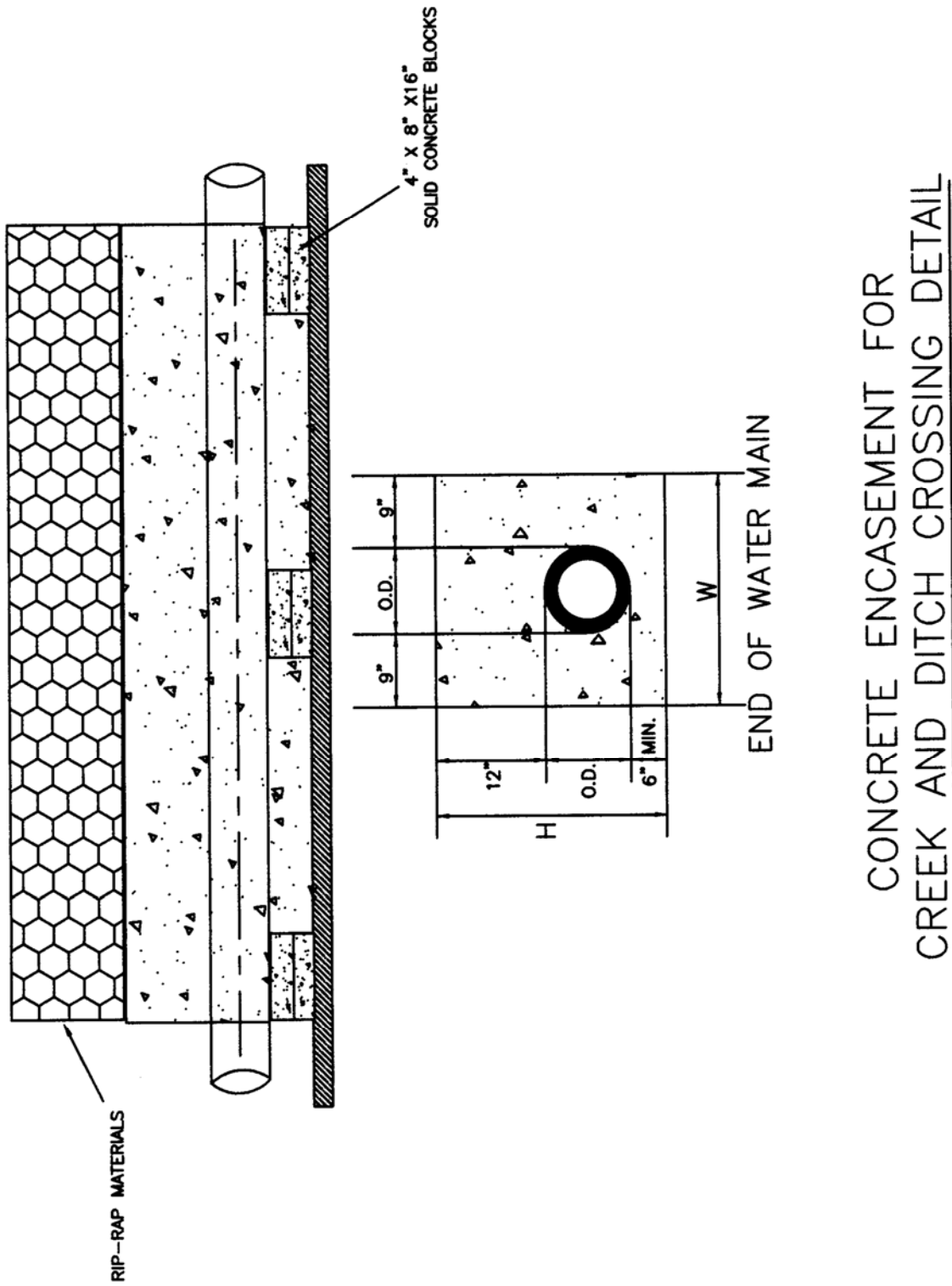
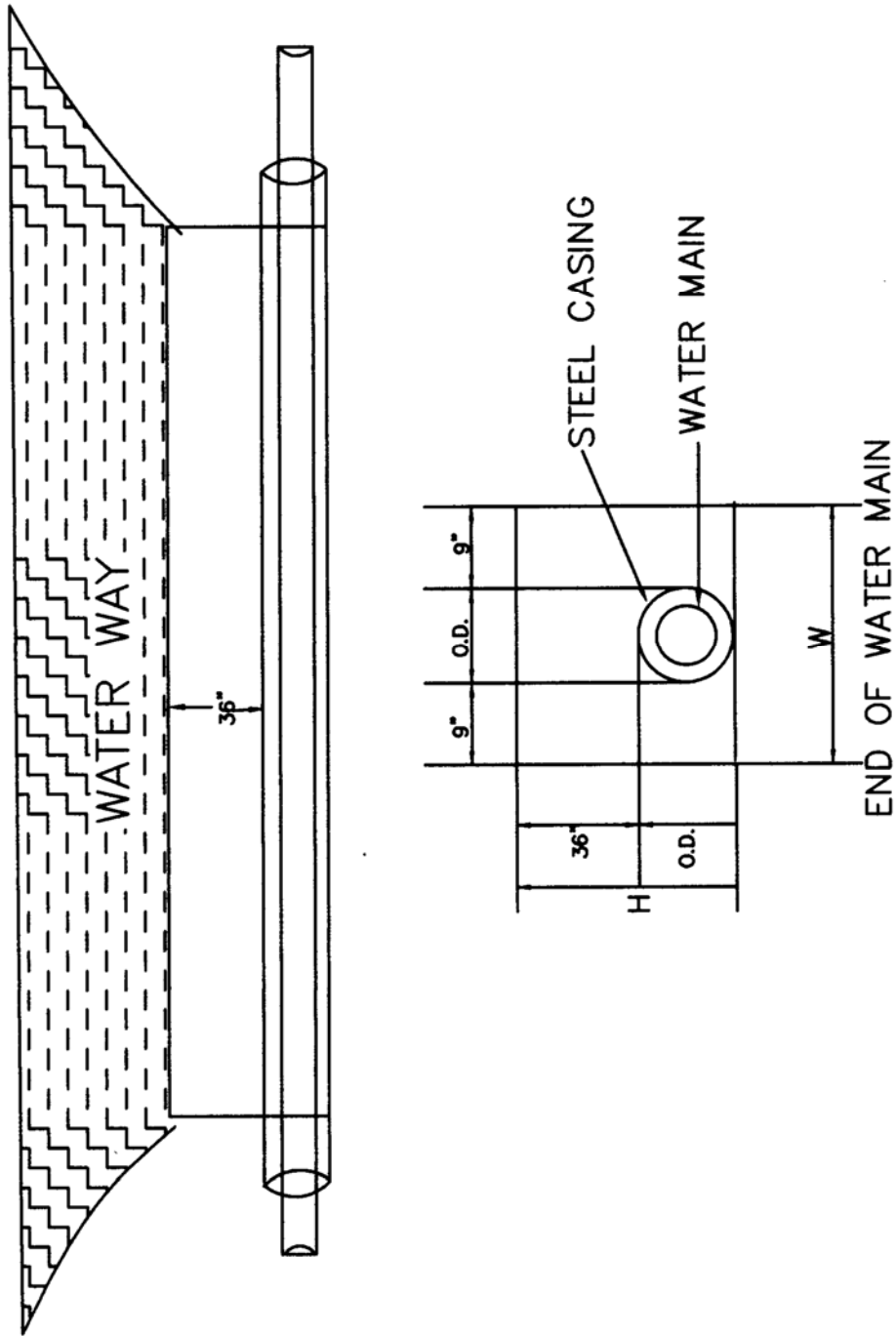

Figure 6 – Ditch and Obstruction Crossing Detail



CONCRETE ENCASUREMENT FOR
CREEK AND DITCH CROSSING DETAIL

Figure 7 – Concrete Encasement for Creek and Ditch Crossing Detail



CREEK AND RIVER CROSSING DETAIL

Figure 8 – Creek and River Crossing Detail

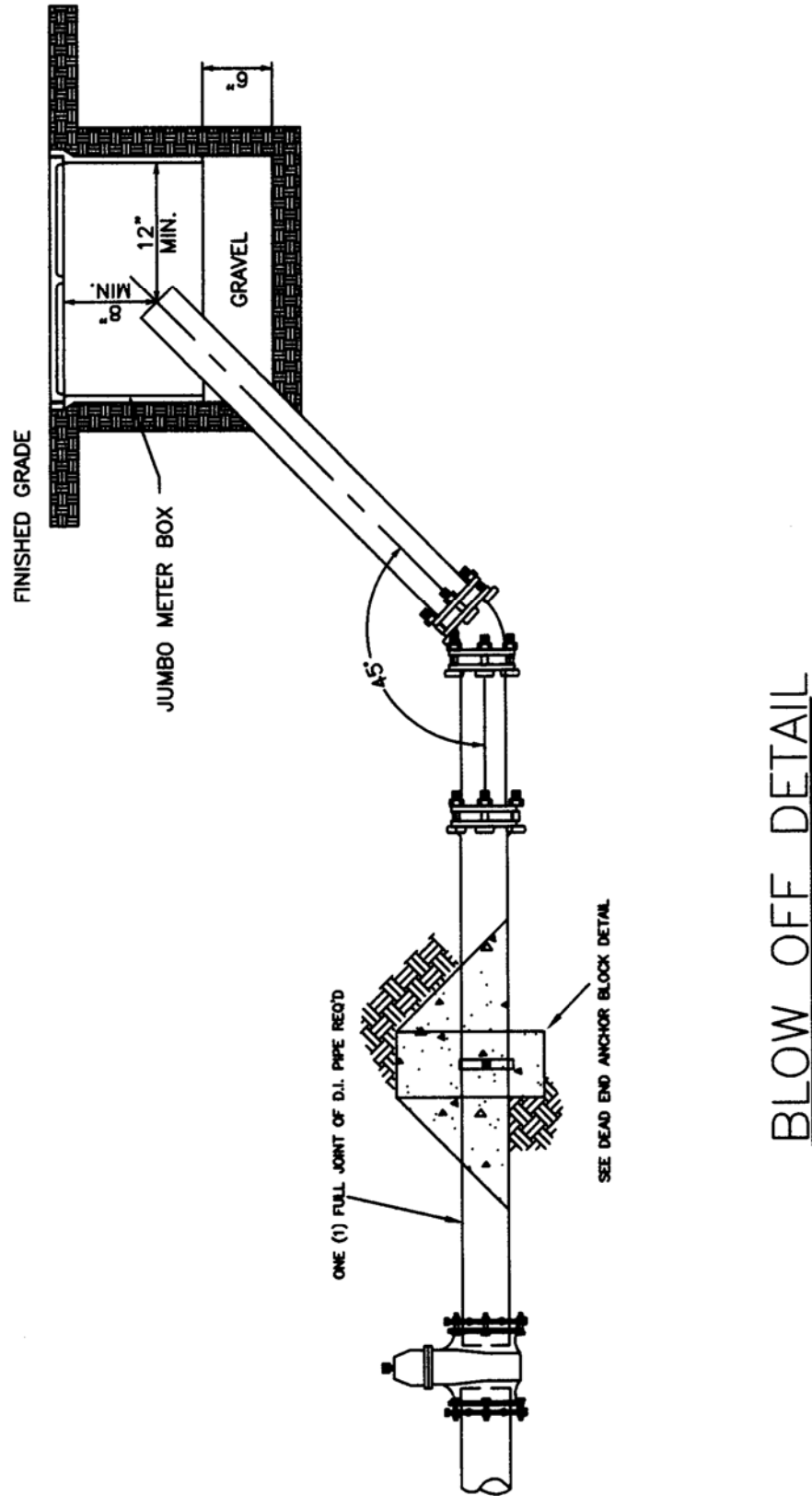

BLOW OFF DETAIL

Figure 9 – Blow Off Detail

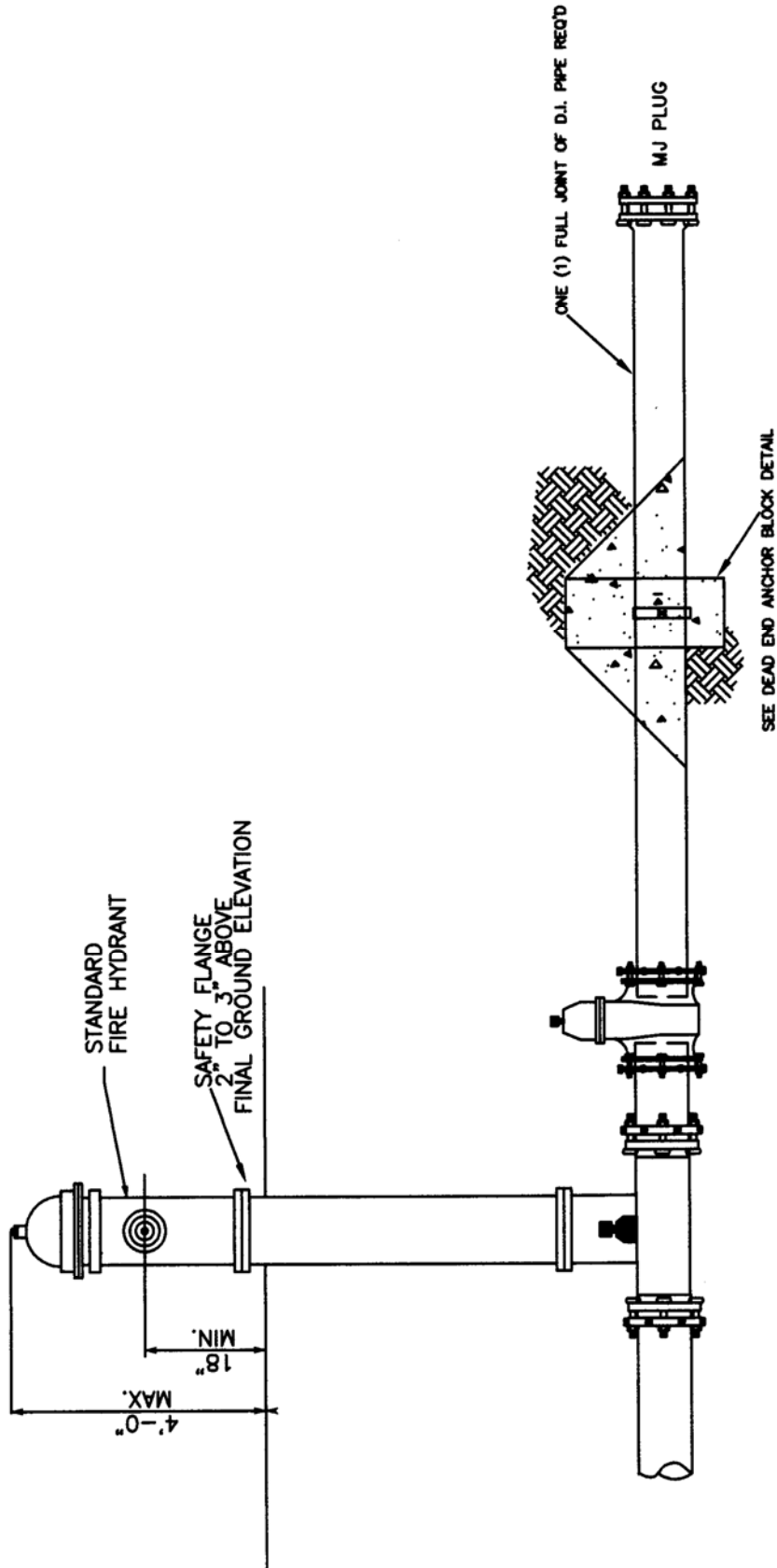

BLOW OFF DETAIL USING FIRE HYDRANT

NOT TO SCALE

Figure 10 – Blow Off Detail Using Fire Hydrant

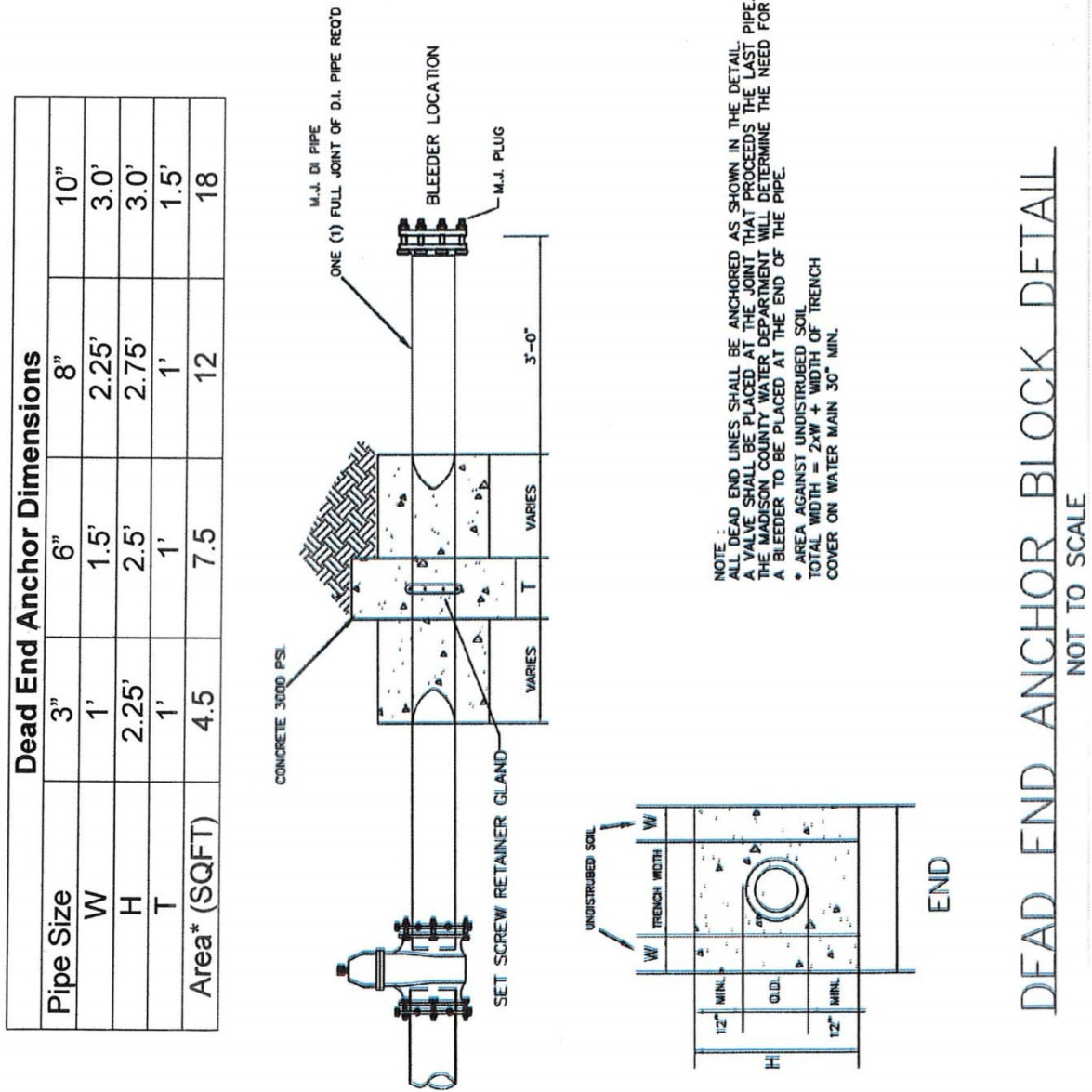

Figure 11 – Dead End Anchor Block Detail

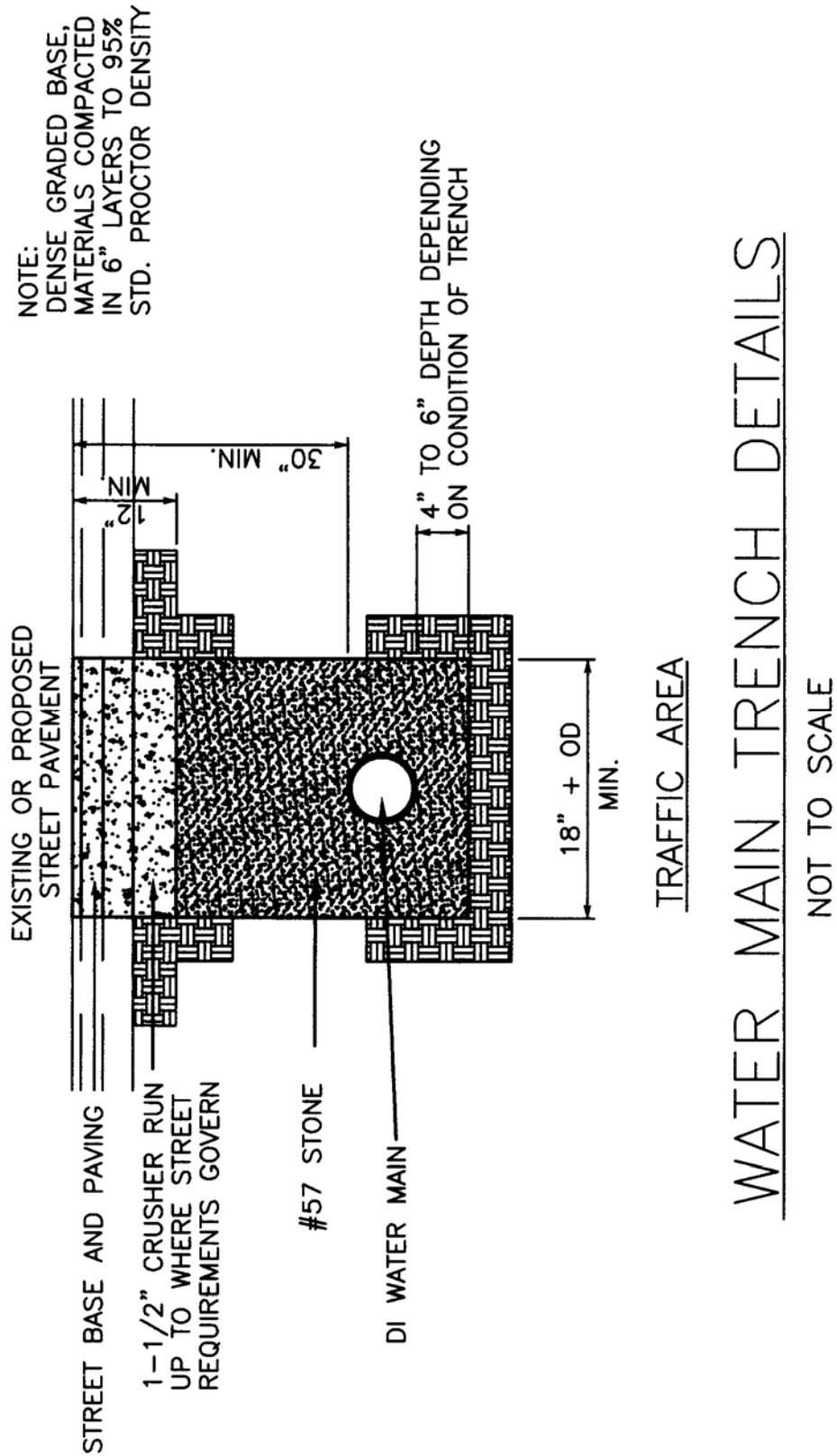
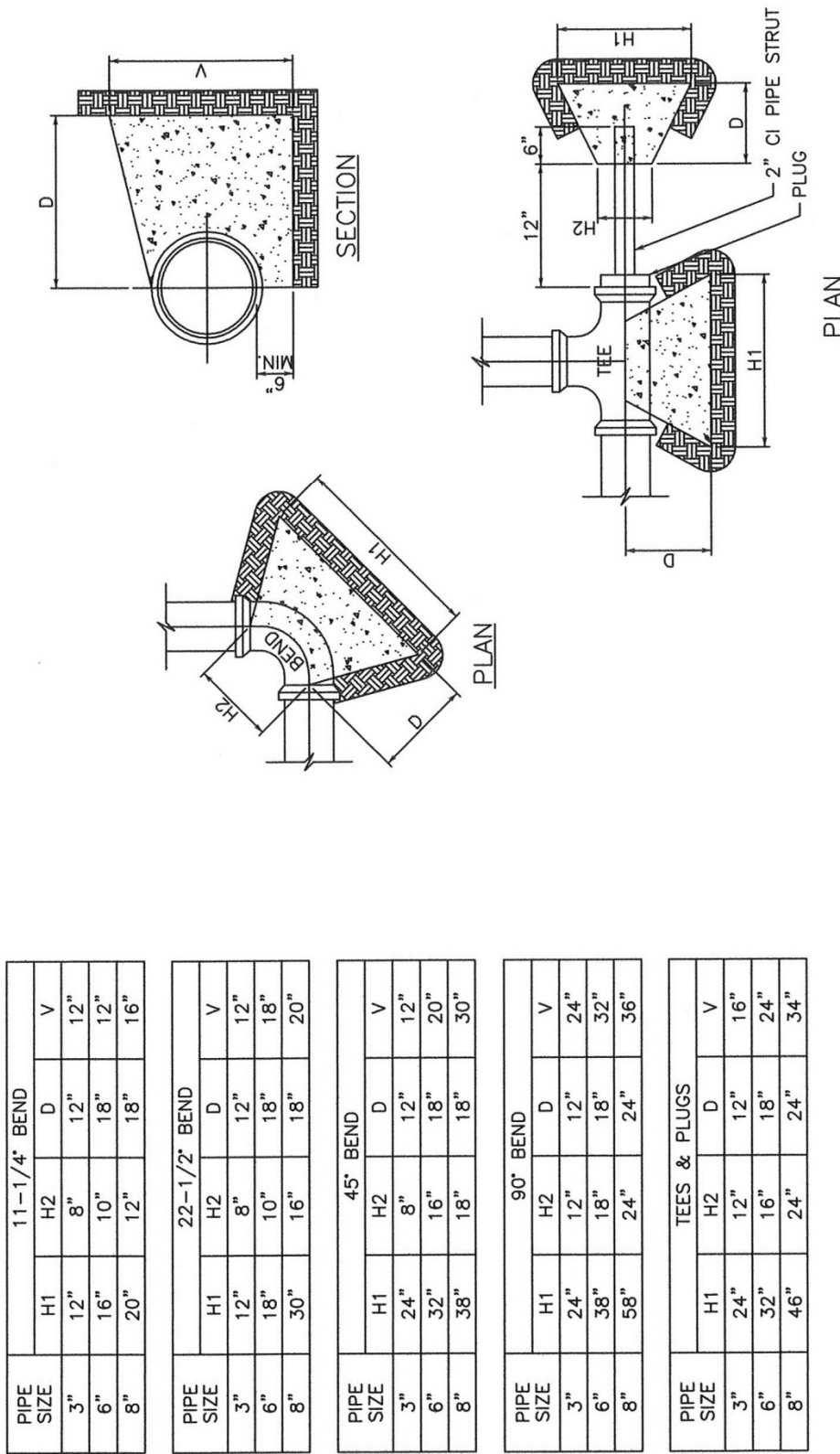

Figure 12 – Water Main Trench Details



CONCRETE THRUST BLOCK DETAIL

NOT TO SCALE

Figure 13 – Concrete Thrust Block Detail

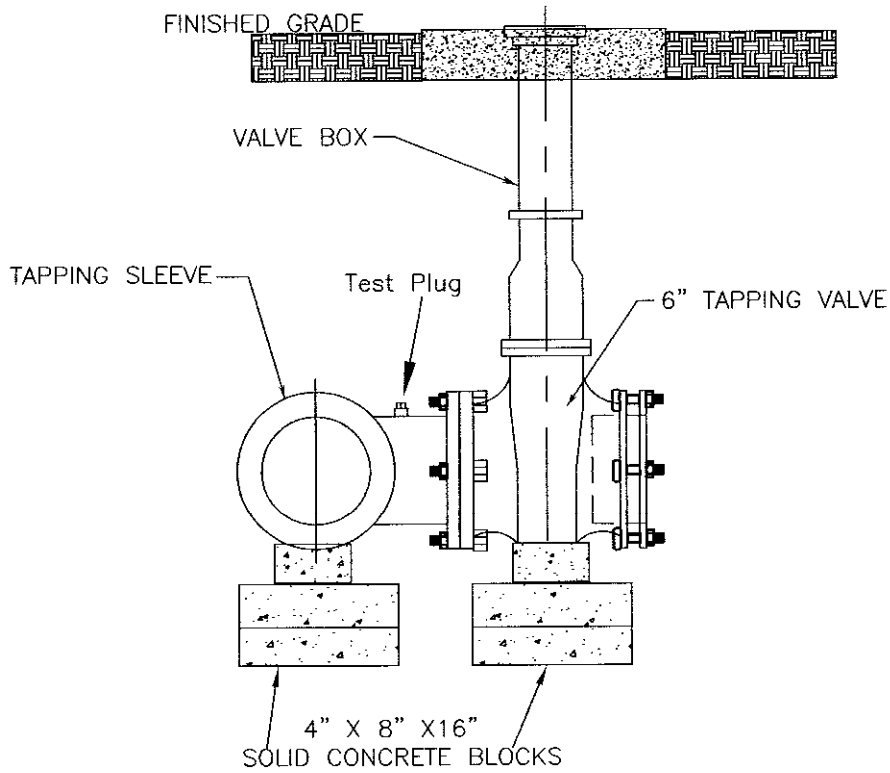

TAPPING SLEEVE & VALVE DETAIL

NOT TO SCALE

Figure 14 – Tapping Sleeve and Valve Detail

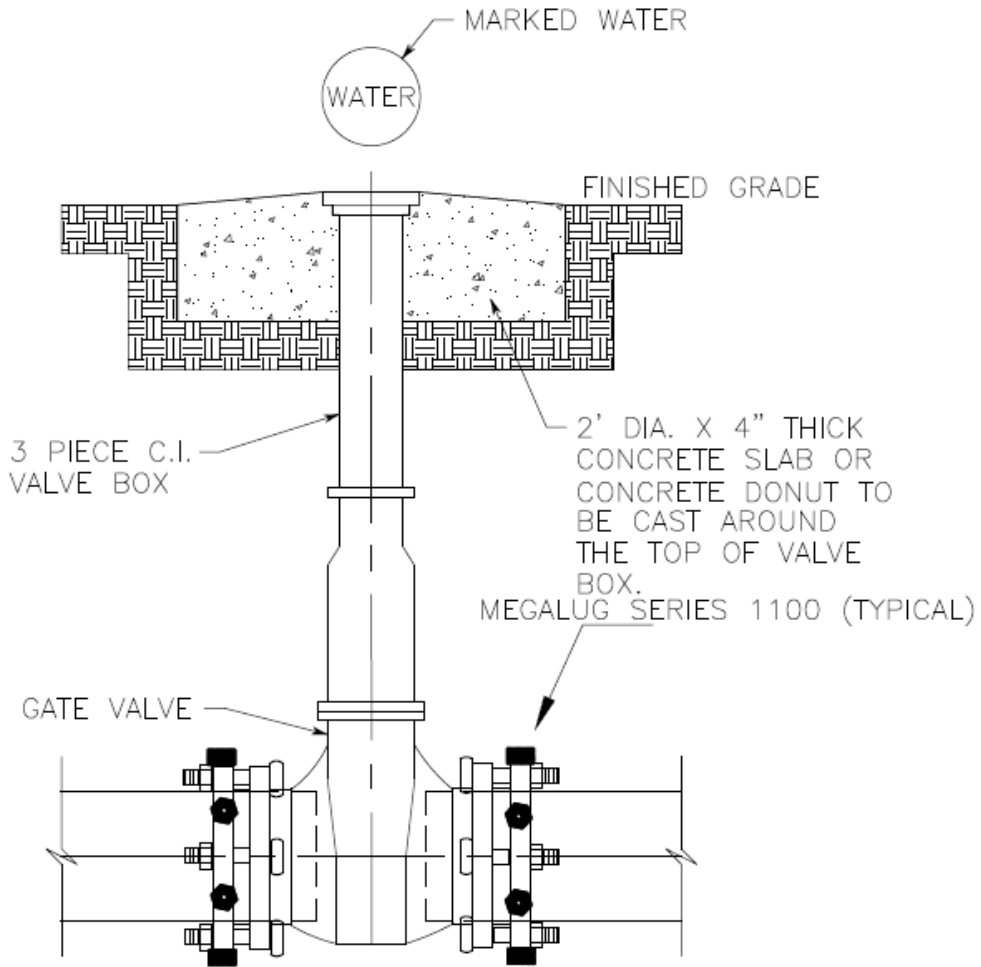

VALVE BOX DETAIL
NOT TO SCALE

Figure 15 – Valve Box Detail

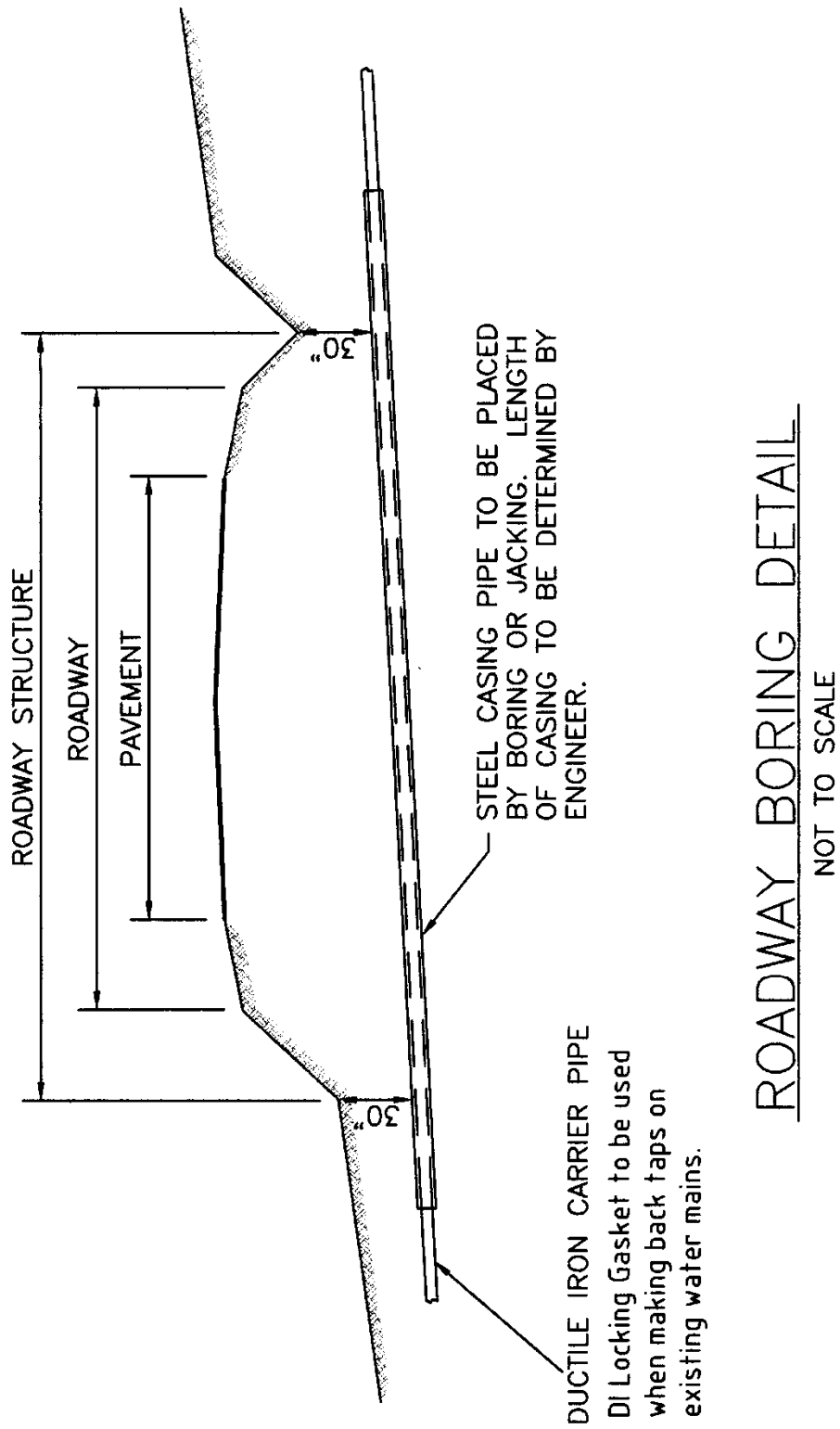
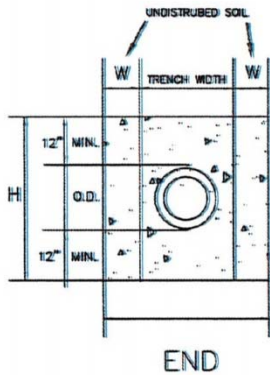
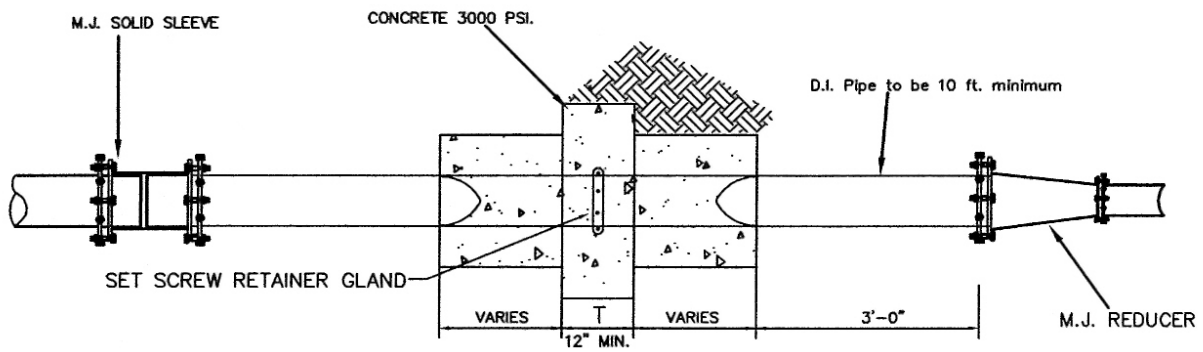

Figure 16 – Roadway Boring Detail

Dead End Anchor Dimensions				
Pipe Size	3"	6"	8"	10"
W	1'	1.5'	2.25'	3.0'
H	2.25'	2.5'	2.75'	3.0'
T	1'	1'	1'	1.5'
Area* (SQFT)	4.5	7.5	12	18



NOTE :
 ALL DEAD END LINES SHALL BE ANCHORED AS SHOWN IN THE DETAIL.
 A VALVE SHALL BE PLACED AT THE JOINT THAT PRECEEDS THE LAST PIPE.
 THE MADISON COUNTY WATER DEPARTMENT WILL DETERMINE THE NEED FOR
 A BLEEDER TO BE PLACED AT THE END OF THE PIPE.
 * AREA AGAINST UNDISTURBED SOIL
 TOTAL WIDTH = 2xW + WIDTH OF TRENCH
 COVER ON WATER MAIN 30" MIN.

ANCHOR BLOCK FOR REDUCER DETAIL

NOT TO SCALE

Figure 17 – Anchor Block for Reducer Detail

