

MADISON COUNTY PURCHASING
DEPARTMENT
100 North Side Square, Room 735
Huntsville, AL 35801

BID SUBMISSION CHECKLIST

Bid #2016-15

Bid Opening Date: April 26, 2016

√	<i>(Please check all completed items)</i>
	Signed, notarized and returned the Illegal Affidavit Forms with bid
	Completed IFB Form, signed and notarized
	Filled in all blanks within the specifications
	Included bid bond, if applicable
	*Included performance bond, if applicable
	Included all requested information in bid package
	Certifications/Licenses/Permits, if applicable
	Certificate of Insurance(s), if applicable
	Acknowledged the Addenda, if applicable
	Put bid number, company name and address on the outside of the envelope(s)
	Sealed bid response
	Cost Sheet on CD, if applicable
	Read specifications thoroughly

MADISON COUNTY COMMISSION
100 NORTH SIDE SQUARE
HUNTSVILLE, ALABAMA 35801

INVITATION FOR BIDS

BID NUMBER: 2016-15

Madison County Commission will accept bids for the Morning View Road Water Main Upgrade Project.

Bids will open on Tuesday, April 26, 2016 at 11:00 a.m.
7th Floor, Room 735 – Madison County Courthouse, Huntsville, Alabama
(See attached specifications)

Current bids are available on our website at www.madisoncountyal.gov

Each vendor submitting a bid must complete the Verified Statements Regarding Unauthorized Aliens.

The Madison County Commission will receive sealed bids until the date and time of bid opening for item(s) meeting, exceeding, or equivalent to specifications. The Madison County Commission reserves the right to accept or reject any and all bids in whole or in part. Failure to comply with any of the requirements contained in this invitation for bids may result in the rejection of the entire bid submitted. Any attachments hereto become a part of the bid and will remain in the bid file. Brand names used in this invitation for bids are for comparison purposes only and are not to be construed as indicating any preference. Any items submitted as equivalent to or exceeding specifications must be described in detail. It is the intent of the Madison County Commission to allow any business selling the type(s) of merchandise described, to participate in our bidding process. If any prospective vendor feels that any part of these specifications would prohibit their company from submitting a bid, or has any questions regarding this bid, you may email the Purchasing Department at sbattler@madisoncountyal.gov prior to the bid opening date.

All bids must be submitted on this form. No errors will be corrected after bids are opened. Bids made out in pencil will NOT be accepted. Vendors must sign and notarize their bid. Failure to do so may result in rejection of bid.

Madison County will accept bids to perform the following work: install approximately 4,300 feet of 12-inch DI water main including hydrants and valves, install new services, pressure test and disinfect the new main, transfer new services to the new main, connect to existing mains, install new meters and backflow preventers for each customer, repair driveways, ROW and landscaping to preconstruction condition as described in the attached Bid Package dated March 2016. The period of performance is 180 days. **There will be a bidder's conference on Tuesday, April 12, 2016 at 9:00am at the Madison County Water Department, 266-B Shields Rd Huntsville, AL 35811.** Attendance is strongly encouraged. Ms. Bailee Robinson will be the point of contact at (256) 746-2871.

The original and one copy of all bid documents and forms provided in Appendix A of the Bid Package must be provided. Additionally, vendors must sign, notarize and return this form with the bid documents. Payment Bond, Performance Bond and a Certificate of Insurance shall be provided post award, prior to execution of the contract.

Alabama Board for General Contractors License Number _____.

Notice on Addenda: Bidders must periodically check Madison County's website for any addenda issued for this procurement. Madison County shall not be responsible for bidder's failure to acquire addenda. The bidder must acknowledge receipt on the addenda on the bid form.

**SUBMIT BID TO: MADISON COUNTY PURCHASING
100 NORTH SIDE SQUARE
ROOM 735
HUNTSVILLE, AL 35801**

**Vendor must show on envelope the bid number and opening date.
Each numbered bid must be in a separate envelope.**

All documents submitted to Madison County will be subject to Alabama's Open Records Laws (Code of Alabama, Title 36-12-40 and 41, as last amended). Due to the provisions of the Open Records Laws and the Competitive Bid Laws (especially Code of Alabama, Title 41-16-24(b)), the Madison County Commission cannot assure any Bidder that any information submitted with the bid, even though marked "Proprietary" will not be open to public inspection and copying.

I hereby affirm that I have not been in any agreement or collusion among vendors or prospective vendors in restraint of freedom of competition, by agreement to bid at a fixed price or to refrain from bidding, or otherwise.

THIS BID MUST BE NOTARIZED.

Subscribed and sworn to before
me this _____ day of
_____ 20_____.

Notary Public

Angela Anderson
Madison County Purchasing Director

Madison County Commission
Awarding Authority

COMPANY NAME: _____

SIGNATURE: _____

PRINT NAME: _____

STREET ADDRESS: _____

CITY: _____ STATE: _____ ZIP CODE: _____

PHONE #: _____ FAX #: _____

EMAIL ADDRESS: _____

FEDERAL ID# _____

DATE: March 28, 2016

Questions regarding specifications for this bid should be sent to Bailee Robinson at brobinson@madisoncountyal.gov or 256-746-2871.

All procurement questions must be sent via email to Sylvia Battle at sbattle@madisoncountyal.gov. Procurement questions will not be permitted via telephone.

ALL VENDORS PLEASE NOTE

Addenda: Bidders must periodically check the County's website for any addenda issued for this procurement. Madison County will not be responsible for a bidder's failure to acquire any addenda issued. The Bidder acknowledges receipt of the following addenda, if applicable:

www.madisoncountyal.gov

Madison County, Alabama

**Bid Package: Including
Scope of Work, Instructions to Bidders, General Conditions, Special
Conditions, Technical Specifications, Contract Documents and
Drawings**

Morning View Road Water Main Upgrade Project

Project Number MCWD 16-004

March 2016

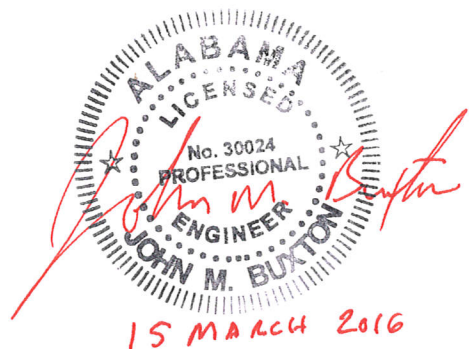

TABLE OF CONTENTS

Section	Page
1. SCOPE OF WORK	
1.1 SUMMARY	1-1
2. INSTRUCTIONS TO BIDDERS	
2.1 BID DOCUMENTS	2-1
2.2 GENERAL CONTRACTOR’S STATE LICENSING REQUIREMENTS	2-1
2.3 EXAMINATION OF BID DOCUMENTS AND THE SITE OF THE WORK	2-1
2.4 PRE-BID CONFERENCE	2-1
2.5 EXPLANATIONS AND INTERPRETATIONS	2-1
2.6 SUBSTITUTIONS	2-2
2.7 PREPARATION AND DELIVERY OF BIDS	2-3
2.8 WITHDRAWAL OR REVISION OF BIDS	2-4
2.9 OPENING OF BIDS	2-5
2.10 INCOMPLETE AND IRREGULAR BIDS	2-5
2.11 BID ERRORS	2-5
2.12 DISQUALIFICATION OF BIDDERS	2-6
2.13 CONSIDERATION OF BIDS	2-6
2.14 UNIT PRICES	2-7
2.15 EXPLANATION OF BID ITEMS	2-7
2.16 AWARD OF CONTRACT	2-10
2.17 POWER OF ATTORNEY	2-11
3. GENERAL CONDITIONS	
3.1 DEFINITIONS	3-1
3.2 INTENT AND INTERPRETATION OF THE CONTRACT DOCUMENTS	3-2
3.3 CONTRACTOR’S REPRESENTATIONS	3-4
3.4 DOCUMENTS FURNISHED TO CONTRACTOR	3-4
3.5 OWNERSHIP OF DRAWINGS	3-4
3.6 SUPERVISION, SUPERINTENDENT AND EMPLOYEES	3-4
3.7 REVIEW OF CONTRACT DOCUMENTS AND FIELD CONDITIONS BY CONTRACTOR	3-5

3.8	SURVEYS BY CONTRACTOR.....	3-6
3.9	SUBMITTALS	3-7
3.10	DOCUMENTS AND SAMPLES AT THE SITE	3-9
3.11	“AS-BUILT” DOCUMENTS.....	3-9
3.12	PROGRESS SCHEDULE	3-10
3.13	EQUIPMENT, MATERIALS AND SUBSTITUTIONS.....	3-10
3.14	SAFETY AND PROTECTION OF PERSONS AND PROPERTY.....	3-11
3.15	HAZARDOUS MATERIALS	3-12
3.16	INSPECTION OF THE WORK.....	3-13
3.17	CORRECTION OF DEFECTIVE WORK.....	3-15
3.18	DEDUCTIONS FOR UNCORRECTED WORK	3-16
3.19	CHANGES IN THE WORK.	3-16
3.20	CLAIMS FOR EXTRA COST OR EXTRA WORK.....	3-19
3.21	DIFFERING SITE CONDITIONS.....	3-20
3.22	CLAIMS FOR DAMAGES.....	3-20
3.23	DELAYS.....	3-20
3.24	RESOLUTION OF CLAIMS AND DISPUTES.....	3-21
3.25	OWNER’S RIGHT TO CORRECT DEFECTIVE WORK	3-22
3.26	OWNER’S RIGHT TO STOP OR SUSPEND THE WORK.....	3-22
3.27	OWNER’S RIGHT TO TERMINATE CONTRACT	3-23
3.28	CONTACTOR’S RIGHT TO SUSPEND OR TERMINATE THE CONTRACT	3-23
3.29	PROGRESS PAYMENTS.....	3-27
3.30	CERTIFICATION AND APPROVALS FOR PAYMENT	3-29
3.31	PAYMENTS WITHHELD.....	3-30
3.32	SUBSTANTIAL COMPLETION	3-31
3.33	OCCUPANCY OR USE PRIOR TO COMPLETION.....	3-33
3.34	FINAL PAYMENT	3-33
3.35	CONTRACTOR’S WARRANTY	3-35
3.36	INDEMNIFICATION AGREEMENT.....	3-36
3.37	CONTRACTOR’S AND SUBCONTRACTORS’ INSURANCE.....	3-37

3.38	PERFORMANCE AND PAYMENT BONDS	3-42
3.39	ASSIGNMENT	3-42
3.40	CONSTRUCTION BY OWNER OR SEPARATE CONTRACTORS	3-43
3.41	SUBCONTRACTS	3-44
3.42	PERMITS, LAWS AND REGULATIONS.....	3-45
3.43	ROYALTIES, PATENTS AND COPYRIGHTS.....	3-46
3.44	USE OF THE SITE.....	3-46
3.45	CUTTING AND PATCHING	3-46
3.46	IN-PROGRESS AND FINAL CLEANUP	3-46
3.47	LIQUIDATED DAMAGES	3-47
3.48	USE OF FOREIGN MATERIALS.....	3-47
4.	SPECIAL CONDITIONS	
4.1	PERIOD OF PERFORMANCE AND SUBSTANTIAL COMPLETION	4-1
4.2	SOURCE OF PROJECT FUNDING	4-1
4.3	COORDINATION WITH MADISON COUNTY WATER DEPARTMENT ..	4-1
4.4	CONTRACT ADMINISTERED BY MADISON COUNTY WATER DEPARTMENT	4-1
4.5	NOTIFICATION REQUIREMENTS	4-1
4.6	ENGINEER FOR THE WORK	4-1
4.7	DESIGNATION OF INSPECTORS	4-2
4.8	EMERGENCY CONTACT INFORMATION	4-2
4.9	OWNER’S REPRESENTATIVE	4-2
4.10	PRECONSTRUCTION VIDEO	4-2
4.11	CONTRACTOR RESPONSIBLE FOR LOCATING UTILITIES	4-2
4.12	DAMAGE TO PROPERTY	4-3
4.13	PRESSURE TESTING, DISINFECTING AND SAMPLING	4-3
4.14	TRAFFIC CONTROL	4-3
4.15	NO STAGGING AREA AVAILABLE	4-3
4.16	MATERIALS FURNISHED BY MADISON COUNTY	4-3
4.17	MATERIALS FURNISHED BY CONTRACTOR	4-4
4.18	ROCK REMOVAL	4-4

4.19	BLASTING	4-4
4.20	FINAL COMPLETION AND ACCEPTANCE.....	4-7
4.21	BUILDER’S RISK INSURANCE NOT REQUIRED	4-7
5.	TECHNICAL SPECIFICATIONS	
5.1	EROSION/SEDIMENT CONTROL AND STORMWATER MANAGEMENT.....	5-1
5.2	SURFACE PREPARATION AND RESTORATION.....	5-1
5.3	INSTALLATION	5-5
5.4	TRENCH EXCAVATION AND BACKFILL	5-9
5.5	CREEK AND DITCH UNDERCROSSINGS.....	5-13
5.6	CONCRETE, AGGREGATES, AND REINFORCING STEEL	5-14
5.7	PRESSURE TESTING REQUIRMENTS.....	5-16
5.8	DISINFECTION AND SAMPLING	5-17
5.9	RECONNECTING SERVICE LINES AND METER BOXES	5-19
5.10	AS-BUILT DRAWINGS.....	5-20

APPENDICES

A. FORMS

A.1	BID FORM	A-2
A.2	BID BOND	A-5
A.3	UNAUTHORIZED ALIEN AFFIDAVIT	A-6
A.4	SWORN AFFIDAVIT FOR SUBCONTRACTORS REGARDING UNAUTHORIZED ALIENS.....	A-7
A.5	SWORN AFFIDAVIT FOR SUBCONTRACTORS REGARDING UNAUTHORIZED ALIENS.....	A-8
A.6	CONTRACTOR’S QUESTIONNAIRE.....	A-9
A.7	SUBCONTRCATOR LIST	A-12

B. CONTRACT DOCUMENTS (SAMPLE)

B.1	CONSTRUCTION CONTRACT.....	A-13
B.2	PAYMENT BOND.....	A-15
B.3	PERFORMANCE BOND.....	A-17

C.	SITE DRAWINGS	
	C.1 CONSTRUCTION DRAWING	A-20
D.	DETAILED DRAWINGS	
	FIGURE 1 EARTH EXCAVATION FOR PVC AND DUCTILE IRON	A-21
	FIGURE 2 ROCK EXCAVATION FOR PVC AND DUCTILE IRON	A-22
	FIGURE 3 DITCH AND OBSTRUCTION CROSSING DETAIL	A-23
	FIGURE 4 DEAD END ANCHOR BLOCK DETAIL	A-24
	FIGURE 5 BLOW OFF DETAIL	A-25
	FIGURE 6 WATER MAIN TRENCH DETAIL	A-26
	FIGURE 7 CONCRETE THRUST BLOCK DETAIL	A-27
	FIGURE 8 VALVE BOX DETAIL	A-28
	FIGURE 9 FIRE HYDRANT INSTALLATION	A-29
	FIGURE 10 SERVICE LINE INSTALLATION	A-30
	FIGURE 11 SAMPLE AS-BUILT DRAWING	A-31

1. SCOPE OF WORK

1.1 SUMMARY.

(a) Scope of Services

The contractor shall:

- Install approximately 4,300 feet of new 12” ductile iron water main, including hydrants and valves. Rock will be encountered in this project;
- Install wattle ditch checks as instructed by the Engineer;
- Install new services on the new main;
- Pressure test and disinfect the new water main;
- Transfer services from existing main to new main;
- Install new meters and backflow preventers for each customer;
- Perform 12” connection on Morning View Rd and an 8” connection on Taylor Denton Ln;
- Repair driveways/culverts to original condition or better;
- Landscape yards and right-of way to original condition or better.

According to the technical specification and drawings provided in this bid package.

(b) Contents. Section 2 of this document provides the Instructions to Bidders. The General Conditions are included in Section 3. Special Conditions are provided in Section 4. The Technical Specifications for the project are described in Section 5. Appendix A includes the contract forms. Appendix B provides samples of contract documents. Drawings depicting the work are included as Appendix C. The Detailed Drawings referenced in the Technical Specifications are provided in Appendix D.

2. INSTRUCTIONS TO BIDDERS

2.1 BID DOCUMENTS. The Bid Documents consist of the Advertisement for Bids, these Instructions to Bidders, any modifications of or supplements to these Instructions to Bidders, the Bid Form and the proposed Contract Documents. The Contract Documents consist of the Construction Contract, the Performance Bond and Payment Bond, the Conditions of the Contract (General, Special, and other Conditions), Technical Specifications including diagrams and drawings, and all addenda issued prior to execution of the Construction Contract. Bid Documents may be obtained or examined as set forth in the Advertisement for Bids.

2.2 GENERAL CONTRACTOR'S STATE LICENSING REQUIREMENTS. All Contractors performing work for Madison County must comply with all applicable licensing and qualification requirements including, but not limited, to Code of Alabama 34-8-1 through 34-8-28 (1975). Generally, when the amount bid for a contract exceeds \$50,000, the bidder must be licensed by the State Licensing Board for General Contractors and must provide Madison County evidence of license before bidding or the bid will not be received by or considered by Madison County, Alabama. A bid exceeding the bid limit stipulated in the bidder's license, or which is for work outside of the type or types of work stipulated in the bidder's license, will not be considered. In case of a joint venture of two or more Contractors, the amount of the bid shall be within the maximum bid limitation as set by the State Licensing Board for General Contractors of the combined limitations of the partners to the joint venture.

2.3 EXAMINATION OF BID DOCUMENTS AND THE SITE OF THE WORK. Before submitting a bid for the Work, the bidders shall carefully examine the Bid Documents, visit the site, and satisfy themselves as to the nature and location of the Work, and the general and local conditions, including weather, the general character of the site, the character and extent of existing work within or adjacent to the site, and any other work being performed thereon at the time of submission of their bids. They shall obtain full knowledge as to transportation, disposal, handling, and storage of materials, and availability of water, electric power, and all other facilities in the area which will have a bearing on the performance of the Work for which they submit their bids. The submission of a bid shall constitute a representation by the bidder that the bidder has made such examination and visit and has judged for and satisfied himself or herself as to conditions to be encountered regarding the character, difficulties, quality, and quantities of work to be performed and the material and equipment to be furnished, and as to the contract requirements involved.

2.4 PRE-BID CONFERENCE. A pre-bid conference will be conducted by Madison County. Attendance at the pre-bid conference is not mandatory; however, it is strongly advised. The date and location of the pre-bid Conference is stated on the invitation for bid form. The pre-bid conference will include a site visit.

2.5 EXPLANATIONS AND INTERPRETATIONS.
(a) Should any bidder observe any ambiguity, discrepancy, omission, or error in the drawings and specifications, or in any other bid document, or be in doubt as to the intention and meaning of these documents, the bidder should immediately report such, in writing, to Ms. Bailee Robinson, Assistant County Engineer, Madison County Water Department, 266 B

Shields Rd, Huntsville, Alabama 35811. Reports may also be sent via email to brobinson@madisoncountyal.gov.

(b) Clarification will be made only by written Addenda sent to all prospective bidders. Madison County will not be responsible in any manner for verbal answers or instructions regarding intent or meaning of the Bid Documents.

(c) In the case of inconsistency in the specifications, a bidder will be deemed to have included in its bid the better quality or greater quantity of the Work involved unless the bidder asked for and obtained the Owner's written clarification of the requirements before submission of a bid.

2.6 SUBSTITUTIONS.

(a) The identification of any product, material, system, item of equipment, or service in the Bid Documents by reference to a trade name, manufacturer's name, model number, etc. (hereinafter referred to as "source"), is intended to establish a required standard of performance, design, and quality and is not intended to limit competition unless the provisions of paragraph (d) below apply.

(b) When the Bid Documents identify only one or two sources, or three or more sources followed by "or approved equal" or similar wording, the bidder's proposal may be based on a source not identified but considered by the bidder to be equal to the standard of performance, design, and quality as specified; however, such substitutions must ultimately be approved by the Owner. If the bidder elects to bid on a substitution without "Pre-bid Approval" as described below, then it will be understood that proof of compliance with specified requirements is the exclusive responsibility of the bidder.

(c) When the Bid Documents identify three or more sources and the list of sources is not followed by "or approved equal" or similar wording, the bidder's proposal shall be based upon one of the identified sources, unless the bidder obtains "Pre-bid Approval" of another source as described below. Under these conditions it will be expressly understood that no product, material, system, item of equipment, or service that is not identified in the Bid Documents or granted "Pre-Bid Approval" will be incorporated into the Work unless such substitution is authorized and agreed upon through a Contract Change Order.

(d) If the Bid Documents identify only one source and expressly provide that it is an approved sole source for the product, material, system, item of equipment, or service, the bidder's proposal must be based upon the identified sole source.

(e) **Procedures for "Pre-bid Approval"**. If it is desired that a product, material, system, piece of equipment, or service from a source different from those sources identified in the Bid Documents be approved as an acceptable source, application for the approval of such source must reach the hands of the Madison County at least ten days prior to the date set for the opening of bids. At Madison County's discretion, this ten day provision may be waived. The application for approval of a proposed source must be accompanied by technical data which the applicant desires to submit in support of the application. Madison County will give consideration to reports from reputable independent testing laboratories, verified experience records showing the reputation of the proposed source with previous users, evidence of reputation of the source for prompt delivery, evidence of reputation of the source for efficiency in servicing its products, or any other pertinent written information. The application to Madison County for approval of a proposed source must be accompanied by a schedule setting forth in which respects the materials or equipment submitted for consideration differ from the materials

or equipment designated in the Bid Documents. The burden of proof of the merit of the proposed substitution is upon the proposer. To be approved, a proposed source must also meet or exceed all express requirements of the Bid Documents. Approval, if granted, shall not be effective until published by Madison County in an addendum to the Bid Documents.

2.7 PREPARATION AND DELIVERY OF BIDS.

(a) Bid Form.

- (i) Bids must be submitted on the Bid Form as contained in the Bid Documents; only one copy is required to be submitted.
- (ii) All information requested of the bidder on the Bid Form must be filled in. The form must be completed by typewriter or hand-printed in ink.
- (iii) Where indicated by the format of the Bid Form, the bidder must specify lump sum prices in both words and figures. In case of discrepancy between the prices shown in words and in figures, the words will govern.
- (iv) All bid items requested in the Bid Form, including alternate bid prices and unit prices for separate items of the Work, must be bid. If a gross sum of bid items is requested in the Proposal Form, the gross sum shall be provided by the bidder.
- (v) The estimated quantities on the Bid Form are for use of Madison County only. Madison County makes no warranty representation or guarantee as the actual quantities
- (vi) In the space provided in the Invitation for Bids Form under “Bidder’s Alabama General Contractors License”, the bidder must insert his or her current general contractor’s state license number, current bid limit, and type(s) of work for which bidder is licensed.
- (vii) The Bid Form shall be properly signed by the bidder. If the bidder is:
 - (1) **an individual**, that individual or his or her “authorized representative” must sign the Proposal Form;
 - (2) **a partnership**, the Proposal Form must be signed by one of the partners or an “authorized representative” of the Partnership;
 - (3) **a corporation**, the president, vice-president, secretary, or “authorized representative” of the corporation shall sign and affix the corporate seal to the Proposal Form.As used in these Instructions to Bidders, “authorized representative” is defined as a person to whom the bidder has granted written authority to conduct business in the bidder’s behalf by signing and/or modifying the bid. Such written authority shall be signed by the bidder (the individual proprietor, or a member of the Partnership, or an officer of the Corporation) and shall be attached to the Proposal Form.

- (viii) Interlineations, alterations or erasures on the Proposal Form must be initialed by the bidder or its “authorized representative”.

(b) Bid Guaranty.

- (i) The Bid Form must be accompanied by a cashier’s check, drawn on an Alabama bank, or a Bid Bond, executed by a surety company duly authorized and qualified to make such bonds in the State of Alabama, payable to Madison County.
- (ii) If a Bid Bond is provided in lieu of a cashier’s check, the bond shall be on a standard form.
- (iii) The amount of the cashier’s check or Bid Bond shall not be less than five percent (5%) of the contractor’s bid, but is not required to be in an amount more than Ten Thousand Dollars (\$10,000).

(c) Other Required Documents. The Bid Package shall include a completed Contractor’s Questionnaire with required attachments and a list of all proposed subcontractors. A subcontractor list is required even if all work is performed by the prime contractor; the bidder must state “no subcontractor” on the Subcontractor List form. Refer to Appendix A for required forms.

(d) Unauthorized Aliens Affidavit (E-Verify Notice). Contractor’s Unauthorized Aliens Affidavit shall be a part of the contact documents and shall be submitted with the bid package. Refer to Appendix A.

(e) Delivery of Bids.

- (i) Bids will be received until the time set, and at the location designated, in the Invitation for Bids unless notice is given of postponement. Any bid not received prior to the time set for opening bids will be rejected absent extenuating circumstances and such bids shall be rejected in all cases where received after other bids are opened.
- (ii) Each bid shall be placed, together with the bid guaranty, in a sealed envelope. On the outside of the envelope the bidder shall write in large letters “Proposal”, below which the bidder shall identify the Project and the Work bid on, the name of the bidder, and the bidder’s current general contractor’s state license number.
- (iii) Bids may be delivered in person or by mail if ample time is allowed for delivery. When sent by mail, the sealed envelope containing the bid, marked as indicated above, shall be enclosed in another envelope for mailing. Bids, delivered in person, sent by US mail, or by delivery service, must be delivered to the Madison County Purchasing Department, 100 Northside Square, Room 735, Huntsville, Alabama 35801.

2.8 WITHDRAWAL OR REVISION OF BIDS.

(a) A bid may be withdrawn prior to the time set for opening of bids, provided a written request, executed by the bidder or the bidder’s “authorized representative”, is filed with the Madison County Purchasing Department prior to that time. The bid will then be returned to the bidder unopened.

(b) A bid which has been sealed in its delivery envelope may be revised by writing the change in price on the outside of the delivery envelope over the signature of the

bidder or the bidder's "authorized representative". In revising the bid in this manner, the bidder must only write the amount of the change in price on the envelope and must not reveal the bid price.

(c) Written communications, signed by the bidder or its "authorized representative", to revise bids will be accepted if received by the Owner prior to the time set for opening bids. The Owner will record the instructed revision upon opening the bid. Such written communication may be by facsimile if so stipulated in Supplemental Instructions to Bidders. In revising the bid in this manner, the bidder must only write the amount of the change in price and must not reveal the bid price.

(d) Except as provided in Section 2.11 of these Instructions to Bidders, no bid shall be withdrawn, modified, or corrected after the time set for opening bids.

2.9 OPENING OF BIDS. Bids will be opened and read publicly at the time and place indicated in the Advertisement for Bids. Bidders or their authorized representatives are invited to be present.

2.10 INCOMPLETE AND IRREGULAR BIDS. A bid that is not accompanied by data required by the Bid Documents, or a bid which is in any way incomplete, may be rejected. Any bid which contains any uninitiated alterations or erasures, or any bid which contains any additions, alternate bids, or conditions not called for, or any other irregularities of any kind, will be subject to rejection. Bids may also be rejected for any of (but not limited to) the following causes

- (a) Failure to utilize bid forms provided by Madison County.
- (b) Lack of signature by an authorized representative on the bid form.
- (c) Failure to properly complete the bid.
- (d) Evidence of collusion among bidders.
- (e) Unauthorized alteration of proposal form.
- (f) Failure to submit a bid bond.
- (g) Failure to note the general contractor's license number as required.

2.11 BID ERRORS.

(a) **Errors and Discrepancies in the Proposal Form.** In case of error in the extension of prices in bids, the unit price will govern. In case of discrepancy between the prices shown in the figures and in words, the words will govern.

(b) **Mistakes within the Bid.** If the low bidder discovers a mistake in its bid, the low bidder may seek withdrawal of its bid without forfeiture of its bid guaranty under the following conditions:

- (i) **Timely Notice:** The low bidder must notify Madison County, Alabama in writing, within three working days after the opening of bids, that a mistake was made. This notice must be given within this time frame whether or not award has been made.
- (ii) **Substantial Mistake:** The mistake must be of such significance as to render the bid price substantially out of proportion to the other bid prices.
- (iii) **Type of Mistake:** The mistake must be due to calculation or clerical error, an inadvertent omission, or a typographical error

which results in an erroneous sum. A mistake of law, judgment, or opinion shall not constitute a valid ground for withdrawal without forfeiture.

- (iv) **Documentary Evidence:** Clear and convincing documentary evidence of the mistake must be presented to Madison County, Alabama as soon as possible, but no later than three working days after the opening of bids.

(c) Madison County's decision regarding a low bidder's request to withdraw its bid without penalty shall be made within 10 days after receipt of the bidder's evidence or by the next regular meeting of Madison County, Alabama. Upon withdrawal of bid without penalty, the low bidder shall be prohibited from (1) doing work on the project as a subcontractor or in any other capacity and (2) bidding on the same project if it is re-bid.

2.12 DISQUALIFICATION OF BIDDERS. Any bidder(s) may be disqualified from consideration for contract award for the following reasons:

(a) **Collusion.** Any agreement or collusion among bidders or prospective bidders in restraint of freedom of competition to bid at a fixed price or to refrain from bidding or otherwise shall render the bids void and shall cause the bidders or prospective bidders participating in such agreement or collusion to be disqualified from submitting further bids to Madison County, Alabama on future lettings. (See § 39-2-6, Code of Alabama 1975, for possible criminal sanctions.)

(b) **Advance Disclosure.** Any disclosure in advance of the terms of a bid submitted in response to an Advertisement for Bids shall render the proceedings void and require re-advertisement and rebid.

(c) **Failure to Settle Other Contracts.** Madison County, Alabama may reject a bid from a bidder who has not paid, or satisfactorily settled, all bills due for labor and material on other contracts in force at the time of letting.

2.13 CONSIDERATION OF BIDS.

(a) After the bids are opened and read publicly, the bid prices will be compared and the results of this comparison will be available to the public. Until the final award of the contract, however, Madison County shall have the right to reject any or all bids, and it shall have the right to waive technical errors and irregularities if, in its judgment, the bidder will not have obtained a competitive advantage and the best interests of Madison County, Alabama will be promoted.

(b) If the Bid Documents request bids for projects or parts of projects in combination or separately, the Bid Documents must include modifications of, or supplements to, these Instructions to Bidders setting forth applicable bid procedures. Award or awards will be made to the lowest responsible and responsive bidder or bidders in accordance with such bid procedures.

(c) The qualifications, ability, and responsibility of all bidders and their proposed sub-contracts will be considered in making the award. Only bids of such contractors who are licensed as required by the Code of Alabama, Titles 34 and 46, as amended, prior to the date of the bid opening will be considered.

2.14 UNIT PRICES.

(a) **Work Bid on a Unit Price Basis.** Where all, or part(s), of the planned Work is bid on a unit price basis, both the unit prices and the extensions of the unit prices constitute a basis of determining the lowest responsible and responsive bidder. In cases of error in the extension of prices of bids, the unit price will govern. A bid may be rejected if any of the unit prices are obviously unbalanced or non-competitive.

(b) **Unit Prices for Application to Change Orders.** As a means of predetermining unit costs for changes in certain elements of the Work, the Bid Documents may require that the bidders furnish unit prices for those items in the Proposal Form. Unit prices for application to changes in the Work are not a basis for determining the lowest bidder. Non-competitive unit prices proposed by the successful bidder may be rejected and competitive prices negotiated by Madison County, Alabama prior to contract award. Unit prices for application to changes in the Work are not effective unless specifically included and agreed upon in the Construction Contract.

2.15 EXPLANATION OF BID ITEMS.

(a) Wattle Ditch Checks.

- (i) Includes all labor, equipment and materials needed to install and maintain wattle ditch check dams. The location of the wattles will be provided throughout the course of the project as instructed by the Engineer of the Work. The Contractor will be paid 50% of the cost for wattles as they are installed, and the Contractor will receive the full 100% of the costs for the wattles upon project completion. This is to ensure the wattles are maintained throughout the project.
- (ii) Payment shall be made at the Contractor's unit price per wattle ditch check dam installed.

(b) 12-Inch DI Water Main Installation.

- (i) Includes all labor and equipment needed to install approximately 4,300 feet of 12-inch ductile iron pipe per the Construction Documents. This includes all trenching, backfilling, installing thrust block and the work needed to connect the new 12" main to the existing 12" main on Morning View Road.
- (ii) Payment shall be made at the Contractor's lump sum price.

(c) Rock Excavated for 12-inch Main Installation.

- (i) Includes all labor and equipment needed to remove rock for the 12-inch water line installation. The method of rock removal will be at the Contractor's discretion. Blasting is permitted according to the Contract Documents. Refer to Section 4.18 and 4.19 in the bid package for details. This line item also includes the labor, equipment and materials needed to properly bed the new main

when rock is encountered. Rock bedding shall be #57 stone. Refer to Figure 2.

- (ii) Payment shall be made at the Contractor's unit price per linear feet of rock excavated during the 12-inch water main installation.

(d) Air Relief Valve Assembly Installation.

- (i) Includes all labor and equipment needed to install each air relief valve as shown on the Construction Drawing. This includes but is not limited to trenching, bedding and backfilling for complete installation.
- (ii) Payment shall be made at the Contractor's unit price per air relief valve installed.

(e) Gate Valve Assembly Installation.

- (i) Includes all labor and equipment needed to install each gate valve as shown on the Construction Drawing. This includes all trenching, pipe/valve bedding, setting valve boxes and backfilling for complete installation.
- (ii) Payment shall be made at the Contractor's unit price per gate valve installed.

(f) Fire Hydrant Assembly Installation.

- (i) Includes all labor and equipment needed to install each fire hydrant assembly as shown on the Construction Drawing. This includes all trenching, bedding and backfilling for complete installation.
- (ii) Payment shall be made at the Contractor's unit price per fire hydrant installed.

(g) Long Side Service Connection.

Contractor must attempt to bore under the road to install the long side services with 2.5" encasement pipe. If limited success with boring, Madison County will direct open cuts for service line installation.

- (i) For Boring: Includes all labor and equipment needed to bore each long side service (service on the opposite side of the road as the 12" DI main) installation as shown on the Construction Drawing. This item includes but is not limited to excavation, boring and backfilling. Long side services require 2.5" encasement pipe to protect the service tubing.
- (ii) For Open-Cutting: Includes all labor, equipment and materials needed to open cut the roadway for long side service installation as shown on the Construction Drawing. This item includes but is not limited to excavation, backfilling the open cut to grade and

maintaining the open cut until Madison County can pave the road. Refer to Figure 4 for details.

- (iii) Payment shall be made at the Contractor's unit price per long side service installed and based on the installation method used (boring or open cut).

(h) Short Side Service Connection.

- (i) Includes all labor and equipment needed to install each short side service (service on the same side of the road as the 12" DI main) as shown on the Construction Drawing. This includes but is not limited to trenching and backfilling to provide complete installation.
- (ii) Payment shall be made at the Contractor's unit price per short side service installed.

(i) New Meter Installation.

- (i) Includes all labor and equipment needed to install a new meter and backflow preventer for each customer. This includes but is not limited to excavating, setting the new meter boxes to grade, reconnecting the meter and backfilling to provide complete installation. Madison County is now replacing existing 12" meter boxes with new 18" meter boxes. The Contractor is responsible for supplying any additional fittings or pipe needed to reconnect each customer to their new meter to account for the change in depth from the old meter box size to the new meter box size.
- (ii) Payment shall be made at the Contractor's unit price per new meter installed.

(j) 8-Inch DI Main Connection.

- (i) Includes all labor and equipment needed to make the 8-inch main connection on Taylor Denton Lane. This includes but it not limited to trenching, installing (parallel to existing 8" main) the minimum amount of joints needed to make the connection and backfilling.
- (ii) Payment shall be made at the Contractor's lump sum price.

(k) Pressure Testing and Disinfection Sampling.

- (i) Includes all labor, material and equipment needed to properly pressure test and disinfect the new water main according to the Contract Documents. This includes installing sample taps for disinfection and sampling purposes and removing the taps upon completion.
- (ii) Payment shall be made at the Contractor's lump sum price.

(l) Driveway/Culvert Repair.

- (i) Includes all labor, equipment and material needed to replace and repair driveways and culverts damaged during water main installation. Concrete and asphalt replacement shall match existing pavement and shall be completed per Contract Documents. Culverts may be removed and replaced if in good condition and if approved by the Engineer. If culvert removed is in poor condition, the Contractor shall replace in like kind. Driveway bores are an option for the Contractor, and the costs associated with driveway bores should be included in this item.
- (ii) Payment shall be made at the Contractor's lump sum price.

(m) Landscaping.

- (i) Includes all labor, equipment and materials needed to landscape the entire disturbed area during construction activities per Contract Documents.
- (ii) Payment shall be made at the Contractor's lump sum price.

2.16 AWARD OF CONTRACT.

(a) The contract shall be awarded to the lowest responsible and responsive bidder unless Madison County, Alabama finds that all the bids are unreasonable or that it is not in the best interest of Madison County, Alabama to accept any of the bids. A responsible bidder is one who, among other qualities determined necessary for performance, is competent, experienced, and financially able to perform the contract. A responsive bidder is one who submits a bid that complies with the terms and conditions of the Advertisement for Bids and the Bid Documents. Minor irregularities in the bid shall not defeat responsiveness.

(b) A bidder to whom award is made will be notified by email and confirmed by letter to the address shown on the Proposal Form at the earliest possible date. Unless other time frames are stipulated in Supplemental Instructions to Bidders, the maximum time frames allowed for each step of the process between the opening of bids and the issuance of an order to proceed with the Work shall be as follows

1.	Award of contract by Madison County Commission	60 calendar days after the opening of bids
2.	Contractor's return of the signed contract, with bonds and evidence of insurance, to Madison County, Alabama	15 calendar days after the contract has been presented to the Contractor for signature
3.	Madison County's approval of the Contractor's bonds and evidence of insurance and completion of	10 calendar days after the Contractor presents complete and acceptable documents to

	contract execution	the Owner
4.	Notice to Proceed issued to the Contractor	Within 15 calendar days after final execution of contract by Madison County, Alabama

The time frames stated above, or as otherwise specified in the Bid Documents, may be extended by written agreement between the parties. Failure by Madison County, Alabama to comply with the time frames stated above or stipulated in Supplemental Instructions to Bidders, or agreed extensions thereof, shall be just cause for the withdrawal of the Contractor's bid and contract without forfeiture of bid security.

(c) Should the successful bidder or bidders to whom the contract is awarded fail to execute the Construction Contract and furnish acceptable Performance and Payment Bonds and satisfactory evidence of insurance within the specified period, Madison County, Alabama shall retain from the bid guaranty, if it is a cashier's check, or recover from the principal or the sureties, if the guaranty is a bid bond, the difference between the amount of the contract as awarded and the amount of the bid of the next lowest responsible and responsive bidder. If no other bids are received, the full amount of the bid guaranty shall be so retained or recovered as liquidated damages for such default. Any sums so retained or recovered shall be the property of Madison County, Alabama.

(d) All bid guaranties, except those of the three lowest bona fide bidders, will be returned immediately after bids have been checked, tabulated, and the relation of the bids established. The bid guaranties of the three lowest bidders will be returned as soon as the contract bonds and the contract of the successful bidder have been properly executed and approved. When the award is deferred for a period of time longer than 45 days after the opening of the bids, all bid guaranties, except those of the potentially successful bidders, shall be returned. If no award is made within the specified period, as it may by agreement be extended, all bids will be rejected, and all guaranties returned. If any potentially successful bidder agrees in writing to a stipulated extension in time for consideration of its bid and its bid was guaranteed with a cashier's check, Madison County, Alabama may permit the potentially successful bidder to substitute a satisfactory bid bond for the cashier's check.

2.17 POWER OF ATTORNEY. Attorneys-in-fact who sign bid bonds or contract bonds must file with each bond a certified and effectively dated copy of their power of attorney.

3. GENERAL CONDITIONS

3.1 DEFINITIONS. Whenever the following terms, or pronouns in place of them, are used in the Contract Documents, the intent and meaning shall be interpreted as follows:

(a) **Contract:** The Contract is the embodiment of the Contract Documents. The Contract represents the entire and integrated agreement between the Owner and Contractor and supersedes any prior written or oral negotiations, representations, or agreements that are not incorporated into the Contract Documents. The Contract may be amended only by a Contract Change Order or a Modification to the Construction Contract. The contractual relationship which the Contract creates between the Owner and the Contractor extends to no other persons or entities. The Contract consists of the following Contract Documents, including all additions, deletions, and modifications incorporated therein before the execution of the Construction Contract:

- (i) Contract
- (ii) Performance and Payment Bonds
- (iii) Conditions of the Contract (General, Supplemental, Special and other Conditions)
- (iv) Specifications
- (v) Drawings
- (vi) Contract Change Orders
- (vii) Modifications to the Construction Contract

(b) **Contract Sum:** The Contract Sum is the total amount payable by the Owner to the Contractor for performance of the Work under the Contract Documents. The term “Contract Sum” means the Contract Sum stated in the Construction Contract as may have been increased or decreased by Change Order(s) in accordance with the Contract Documents.

(c) **Contract Time:** The Contract Time is the period of time in which the Contractor must complete the Work. The date on which the Contract Time begins is specified in the written Notice to Proceed issued to the Contractor by the Owner. The term “Contract Time” means the Contract Time stated in the Construction Contract as may have been extended by Change Order(s) in accordance with the Contract Documents. The term “day” as used in the Contract Documents shall mean calendar day unless otherwise specifically defined.

(d) **Contractor:** The Contractor is the person or persons, firm, partnership, joint venture, association, corporation, cooperative, limited liability company, or other legal entity, identified as such in the Construction Contract. The term “Contractor” means the Contractor or the Contractor’s authorized representative.

(e) **Defective Work:** The term “Defective Work” shall apply to:

- (i) Any product, material, system, equipment, or service, or its installation or performance, which does not conform to the requirements of the Contract Documents,
- (ii) in-progress or completed Work the workmanship of which does not conform to the quality specified or, if not specified, to the quality produced by skilled workers performing work of a similar nature on similar projects in the state,
- (iii) Substitutions and deviations not properly submitted and approved or otherwise authorized,

- (iv) Temporary supports, structures, or construction which will not produce the results required by the Contract Documents, and
- (v) Materials or equipment rendered unsuitable for incorporation into the Work due to improper storage or protection.

(f) **Drawings:** The Drawings are the portions of the Contract Documents showing graphically the design, location, layout, and dimensions of the Work, in the form of plans, elevations, sections, details, schedules, and diagrams.

(g) **Notice to Proceed:** A Notice to Proceed is issued by the Owner, fixing the date on which the Contractor shall begin the prosecution of the Work, which is also the date on which the Contract Time shall begin.

(h) **Owner:** The Owner is the entity identified as such in the Construction Contract and is referred to throughout the Contract Documents as if singular in number. The term "Owner" means the Owner or the Owner's authorized representative. The term "Owner" as used herein shall be synonymous with the term "Awarding Authority" as defined and used in Title 39 - Public Works, Code of Alabama, 1975, as amended.

(i) **The Project:** The Project is the total construction of which the Work required by these Contract Documents may be the entirety or only a part with other portions to be constructed by the Owner or separate contractors.

(j) **Specifications:** The Specifications are that portion of the Contract Documents which set forth in writing the standards of quality and performance of products, equipment, materials, systems, and services and workmanship required for acceptable performance of the Work.

(k) **Subcontractor:** A Subcontractor is a person or entity who is undertaking the performance of any part of the Work by virtue of a contract with the Contractor. The term "Subcontractor" means a Subcontractor or its authorized representatives.

(l) **The Work:** The Work is the construction and services required by the Contract Documents, and includes all labor, materials, supplies, equipment, and other items and services as are necessary to produce the required construction and to fulfill the Contractor's obligations under the Contract. The Work may constitute the entire Project or only a portion of it.

3.2 INTENT AND INTERPRETATION OF THE CONTRACT DOCUMENTS.

(a) **Intent.** It is the intent of the Contract Documents that the Contractor shall properly execute and complete the Work described by the Contract Documents, and unless otherwise provided in the Contract, the Contractor shall provide all labor, materials, equipment, tools, construction equipment and machinery, water, heat, utilities, transportation, and other facilities and services, whether temporary or permanent and whether or not incorporated or to be incorporated in the Work, in full accordance with the Contract Documents and reasonably inferable from them as being necessary to produce the indicated results.

(b) **Complementary Documents.** The Contract Documents are complementary. If Work is required by one Contract Document, the Contractor shall perform the Work as if it were required by all of the Contract Documents. However, the Contractor shall be required to perform Work only to the extent that is consistent with the Contract Documents and reasonably inferable from them as being necessary to produce the indicated results.

(c) **Order of Precedence.** Should any discrepancy arise between the various elements of the Contract Documents, precedence shall be given to them in the following order

unless to do so would contravene the apparent Intent of the Contract Documents stated in preceding Paragraph (a):

- (i) The Construction Contract.
- (ii) Addenda, with those of later date having precedence over those of earlier date.
- (iii) General Conditions of the Contract.
- (iv) Supplementary or Special Conditions (or other Conditions which modify the General Conditions of the Contract).
- (v) The Specifications.
- (vi) Details appearing on the Drawings; large scale details shall take precedence over smaller scale details.
- (vii) The Drawings; large scale drawings shall take precedence over smaller scale drawings.

(d) Organization. Except as may be specifically stated within the technical specifications, neither the organization of the Specifications into divisions, sections, or otherwise, nor any arrangement of the Drawings shall control how the Contractor subcontracts portions of the Work or assigns Work to any trade.

(e) Interpretation.

- (i) The Contract Documents shall be governed by and construed in accordance with the laws of the State of Alabama.
- (ii) The Contract Documents shall be interpreted collectively, each part complementing the others and consistent with the Intent of the Contract Documents stated in preceding Paragraph (a). Unless an item shown or described in the Contract Documents is specifically identified to be furnished or installed by the Owner or others or is identified as "Not In Contract" ("N.I.C."), the Contractor's obligation relative to that item shall be interpreted to include furnishing, assembling, installing, finishing, and/or connecting the item at the Contractor's expense to produce a product or system that is complete, appropriately tested, and in operative condition ready for use or subsequent construction or operation of the Owner or separate contractors. The omission of words or phrases for brevity of the Contract Documents, the inadvertent omission of words or phrases, or obvious typographical or written errors shall not defeat such interpretation as long as it is reasonably inferable from the Contract Documents as a whole.
- (iii) Words or phrases used in the Contract Documents which have well-known technical or construction industry meanings are to be interpreted consistent with such recognized meanings unless otherwise indicated.
- (iv) Except as noted otherwise, references to standard specifications or publications of associations, bureaus, or organizations shall mean the latest edition of the referenced standard specification or publication as of the date of the Invitation for Bids.
- (v) In the case of inconsistency between Drawings and Specifications or within either document not clarified by addendum, the better

quality or greater quantity of Work shall be provided in accordance with the Owner's interpretation.

- (vi) Generally, portions of the Contract Documents written in longhand take precedence over typed portions, and typed portions take precedence over printed portions.
- (vii) Any doubt as to the meaning of the Contract Documents or any obscurity as to the wording of them shall be promptly submitted in writing to the Owner for written interpretation, explanation, or clarification.
- (viii) Severability. The partial or complete invalidity of any one or more provision of this Contract shall not affect the validity or continuing force and effect of any other provision.

3.3 CONTRACTOR'S REPRESENTATIONS. By executing the Contract the Contractor represents to the Owner:

(a) The Contractor has visited the site of the Work to become familiar with local conditions under which the Work is to be performed and to evaluate reasonably observable conditions as compared with requirements of the Contract Documents.

(b) The Contractor shall use its best skill and attention to perform the Work in an expeditious manner consistent with the Contract Documents.

(c) The Contractor is an independent contractor and in performance of the Contract remains and shall act as an independent contractor having no authority to represent or obligate the Owner in any manner unless authorized by the Owner in writing.

3.4 DOCUMENTS FURNISHED TO CONTRACTOR. Unless otherwise provided in the Contract Documents, five (5) sets of Drawings and Technical Specifications will be furnished to the Contractor by the Owner without charge. Other copies requested will be furnished at reproduction cost.

3.5 OWNERSHIP OF DRAWINGS. All original or duplicated Drawings, Specifications, and other documents prepared by the Owner, and furnished to the Contractor are the property of the Owner and are to be used solely for this Project and not to be used in any manner for other work. Upon completion of the Work, all copies of Drawings and Specifications, with the exception of the Contractor's record set, shall be returned or accounted for by the Contractor to the Owner, on request.

3.6 SUPERVISION, SUPERINTENDENT AND EMPLOYEES.

(a) **Supervision and Construction Methods.**

- (i) The term "Construction Methods" shall be interpreted as the construction means, methods, techniques, sequences, and procedures utilized by the Contractor in performing the Work. The Contractor is solely responsible for supervising and coordinating the performance of the Work, including the selection of Construction Methods, unless the Contract Documents give other specific instructions concerning these matters.

- (ii) The Contractor is solely and completely responsible for job site safety, including the protection of persons and property in accordance with Section 3.14.
- (iii) The Contractor shall be responsible to the Owner for acts and omissions of not only the Contractor and its agents and employees, but all persons and entities, and their agents and employees, who are performing portions of the Work for or on behalf of the Contractor or any of its Subcontractors.
- (iv) The Contractor shall be responsible to inspect the in-progress and completed Work to verify its compliance with the Contract Documents and to insure that any element or portion of the Work upon which subsequent Work is to be applied or performed is in proper condition to receive the subsequent Work.

(b) Superintendent.

- (i) The Contractor shall employ and maintain a competent level of supervision for the performance of the Work at the Project site, including a superintendent who shall:
 - (1) Have full authority to receive instructions from the Owner and to act on those instructions; and
 - (2) Be present at the Project site at all times during which Work is being performed.
- (ii) Before beginning performance of the Work, the Contractor shall notify the Owner of the name and qualifications of its proposed superintendent so that the Owner may review the individual's qualifications. If, for reasonable cause, the Owner refuses to approve the individual, or withdraws its approval after once giving it, the Contractor shall name a different superintendent for the Owner's review and approval. Any disapproved superintendent will not perform in that capacity thereafter at the Project site.

(c) Employees. The Contractor shall permit only fit and skilled persons to perform the Work. The Contractor shall enforce safety procedures, strict discipline, and good order among persons performing the Work. The Contractor will remove from its employment on the Project any person who deliberately or persistently produces non-conforming Work or who fails or refuses to conform to reasonable rules of personal conduct contained in the Contract Documents or implemented by the Owner and delivered to the Contractor in writing during the course of the Work.

3.7 REVIEW OF CONTRACT DOCUMENTS AND FIELD CONDITIONS BY CONTRACTOR.

(a) In order to facilitate assembly and installation of the Work in accordance with the Contract Documents, before starting each portion of the Work, the Contractor shall examine and compare the relevant Contract Documents, and compare them to relevant field measurements made by the Contractor and any conditions at the site affecting that portion of the Work.

(b) If the Contractor discovers any errors, omissions, or inconsistencies in the Contract Documents, the Contractor shall promptly report them to the Owner as a written request

for information that includes a detailed statement identifying the specific Drawings or Specifications that are in need of clarification and the error, omission, or inconsistency discovered in them.

- (i) The Contractor shall not be expected to act as a licensed design professional and ascertain whether the Contract Documents comply with applicable laws, statutes, ordinances, building codes, and rules and regulations, but the Contractor shall be obligated to promptly notify the Owner of any such noncompliance discovered by or made known to the Contractor. If the Contractor performs Work without fulfilling this notification obligation, the Contractor shall pay the resulting costs and damages that would have been avoided by such notification.
- (ii) The Contractor shall not be liable to the Owner for errors, omissions, or inconsistencies that may exist in the Contract Documents, or between the Contract Documents and conditions at the site, unless the Contractor knowingly fails to report a discovered error, omission, or inconsistency to the Owner, in which case the Contractor shall pay the resulting costs and damages that would have been avoided by such notification.

(c) If the Contractor considers the Owner's response to a request for information to constitute a change to the Contract Documents involving additional costs and/or time, the Contractor shall follow the procedures of Section 3.20, Claims for Extra Cost or Extra Work.

(d) If, with undue frequency, the Contractor requests information that is obtainable through reasonable examination and comparison of the Contract Documents, site conditions, and previous correspondence, interpretations, or clarifications, the Contractor shall be liable to the Owner for reasonable charges from the Owner for the additional services required to review, research, and respond to such requests for information.

3.8 SURVEYS BY CONTRACTOR.

(a) The Contractor shall provide competent engineering services to assure accurate execution of the Work in accordance with the Contract Documents. The Contractor shall verify the figures given for the contours, approaches, and locations shown on the Drawings before starting any Work and be responsible for the accuracy of the finished Work. Without extra cost to the Owner, the Contractor shall engage a licensed surveyor if necessary to verify boundary lines, keep within property lines, and shall be responsible for encroachments on rights or property of public or surrounding property owners.

(b) The Contractor shall establish all base lines for the location of the principal components of the Work and make all detail surveys necessary for construction, including grade stakes, batter boards and other working points, lines, and elevations. If the Work involves alteration of or addition to existing structures or improvements, the Contractor shall locate and measure elements of the existing conditions as is necessary to facilitate accurate fabrication, assembly, and installation of new Work in the relationship, alignment, and/or connection to the existing structure or improvement as is shown in the Contract Documents.

3.9 SUBMITTALS.

(a) Where required by the Contract Documents, the Contractor shall submit shop drawings, product data, samples, and other information (hereinafter referred to as Submittals) to the Owner for the purpose of demonstrating the way by which the Contractor proposes to conform to the requirements of the Contract Documents. Submittals which are not required by the Contract Documents may be returned by the Owner without action.

(b) The Contractor shall be responsible to the Owner for the accuracy of its Submittals and the conformity of its submitted information to the requirements of the Contract Documents. Each Submittal shall bear the Contractor's approval, evidencing that the Contractor has reviewed and found the information to be in compliance with the requirements of the Contract Documents. Submittals which are not marked as reviewed and approved by the Contractor may be returned by the Owner without action.

(c) The Contractor shall prepare and deliver its submittals to the Owner sufficiently in advance of construction requirements and in a sequence as to cause no delay in the Work or in the activities of the Owner or of separate contractors. In coordinating the Submittal process with its construction schedule, the Contractor shall allow sufficient time to permit adequate review by the Owner.

(d) By approving a Submittal the Contractor represents not only that the element of Work presented in the Submittal complies with the requirements of the Contract Documents, but also that the Contractor has:

- (i) Found the layout and/or dimensions in the Submittal to be comparable with those in the Contract Documents and other relevant Submittals and has made field measurements as necessary to verify their accuracy, and
- (ii) Determined that products, materials, systems, equipment, and/or procedures presented in the Submittal are compatible with those presented, or being presented, in other relevant Submittals and with the Contractor's intended Construction Methods.

(e) The Contractor shall not fabricate or perform any portion of the Work for which the Contract Documents require Submittals until the respective Submittals have been approved by the Owner.

(f) In the case of a resubmission, the Contractor shall direct specific attention to all revisions in a Submittal. The Owner's approval of a resubmission shall not apply to any revisions that were not brought to the Owner's attention.

(g) If the Contract Documents specify that a Submittal is to be prepared and sealed by a registered architect or licensed engineer retained by the Contractor, all drawings, calculations, specifications, and certifications of the Submittal shall bear the Alabama seal of registration and signature of the registered/licensed design professional who prepared them or under whose supervision they were prepared. The Owner shall be entitled to rely upon the adequacy, accuracy and completeness of such a Submittal, provided that all performance and design criteria that such Submittal must satisfy are sufficiently specified in the Contract Documents. The Owner will review, approve, or take other appropriate action on such a Submittal only for the limited purpose of checking for conformance with information given and the design concept expressed in the Contract Documents. The Contractor shall not be responsible for the adequacy of the performance or design criteria specified in the Contract Documents.

(h) Deviations.

- (i) Madison County inspectors are authorized by the Owner to approve “minor” deviations from the requirements of the Contract Documents. “Minor” deviations are defined as those which are in the interest of the Owner, do not materially alter the quality or performance of the finished Work, and do not affect the cost or time of performance of the Work. Deviations which are not “minor” may be authorized only by the Owner through the Change Order procedures of Section 3.19.
- (ii) Any deviation from the requirements of the Contract Documents contained in a Submittal shall be clearly identified as a “Deviation from Contract Requirements” (or by similar language) within the Submittal and, in a letter transmitting the Submittal to the Owner, the Contractor shall direct the Owner’s attention to, and request specific approval of, the deviation. Otherwise, the Owner’s approval of a Submittal does not constitute approval of deviations from the requirements of the Contract Documents contained in the Submittal.
- (iii) The Contractor shall bear all costs and expenses of any changes to the Work, changes to work performed by the Owner or separate contractors required to accommodate an approved deviation unless the Contractor has specifically informed the Owner in writing of the required changes and a Change Order has been issued authorizing the deviation and accounting for such resulting changes and costs.

(i) Owner’s Review and Approval.

- (i) The Owner will review the Contractor’s Submittals for conformance with requirements of, and the design concept expressed in, the Contract Documents and will approve or take other appropriate action upon them. This review is not intended to verify the accuracy and completeness of details such as dimensions and quantities, or to substantiate installation instructions or performance of equipment or systems, all of which remain the responsibility of the Contractor. However, the Owner shall advise the Contractor of any errors or omissions which the Owner may detect during this review. The Owner’s approval of a specific item shall not indicate approval of an assembly of which the item is a component.
- (ii) The Owner will review and respond to all Submittals with reasonable promptness to avoid delay in the Work or in the activities of the Owner, Contractor, or separate contractors, while allowing sufficient time to permit adequate review.
- (iii) No corrections or changes to Submittals indicated by the Owner will be considered as authorizations to perform Extra Work. If the Contractor considers such correction or change of a Submittal to require Work which differs from the requirements of the Contract

Documents, the Contractor shall promptly notify the Owner in writing in accordance with Section 3.20, Claims for Extra Cost or Extra Work.

(j) **Conformance with Submittals.** The Work shall be constructed in accordance with approved Submittals.

3.10 DOCUMENTS AND SAMPLES AT THE SITE.

(a) **“As Issued” Set.** The Contractor shall maintain at the Project site, in good order, at least one copy of all Addenda, Change Orders, supplemental drawings, written directives and clarifications, and approved Submittals intact as issued, and an updated construction schedule.

(b) **“Posted” Set.** The Contractor shall maintain at the Project site, in good order, at least one set of the Drawings and Project Manual into which the Contractor has “posted”(incorporated) all Addenda, Change Orders, supplemental drawings, clarifications, and other information pertinent to the proper performance of the Work. The Contractor shall assure that all sets of the Drawings and Project Manuals being used by the Contractor, Subcontractors, and suppliers are “posted” with the current information to insure that updated Contract Documents are used for performance of the Work.

(c) The documents and samples required by this Section to be maintained at the Project site shall be readily available to the Owner and their representatives.

3.11 “AS-BUILT” DOCUMENTS. Unless otherwise provided in the Contract Documents, the Contractor shall deliver two (2) sets of “As-built” documents, as described herein, to the Owner upon completion of the Work. Each set of “As-built” documents shall consist of a copy of the Record of Coatings Applied, Record of Repairs, and Project Manual, in like-new condition, into which the Contractor has neatly incorporated all Addenda, Change Orders, supplemental drawings, clarifications, field changes, corrections, selections, and other information as required herein or specified elsewhere in the Contract Documents.

(a) **Drawings**

(i) To the greatest extent practicable, information shall be carefully drawn and lettered, in ink, on the Drawings in the form of sketches, details, plans, notes, and dimensions as required to provide a fully dimensioned record of Work. When required for clarity, sketches, details, or partial plans shall be on supplemental sheets and bound into the Drawings and references on the drawing being revised.

(ii) Any entry of information made in the Drawings that is the result of an Addendum or Change Order, shall identify the Addendum or Change Order from which it originated.

(b) **Project Manual**

(i) A copy of all Addenda and Change Orders, excluding drawings thereof, shall be bound in the front of the Project Manual.

(ii) Where a document, form, or entire specification section is revised, the latest issue shall be bound into the Project Manual in the place of the superseded issue.

(iii) Where information within a specification section is revised, the deleted or revised information shall be drawn through in ink and an adjacent note added identifying the Addendum or Change Order containing the revised information.

(c) Within ten days after the Date of Substantial Completion of the Work, or the last completed portion of the Work, the Contractor shall submit the "As-built" documents to the Owner for approval. If the Owner requires that any corrections be made, the documents will be returned in a reasonable time for correction and resubmission.

3.12 PROGRESS SCHEDULE.

(a) The Contractor, shall within fifteen days after the date of commencement stated in the Notice to Proceed, or such other time as may be provided in the Contract Documents, prepare and submit to the Owner for review and approval a practicable construction schedule informing the Owner of the order in which the Contractor plans to carry on the Work within the Contract Time. The Owner's review and approval of the Contractor's construction schedule shall be only for compliance with the specified format, Contract Time, and suitability for monitoring progress of the Work and shall not be construed as a representation that the Owner has analyzed the schedule to form opinions of sequences or durations of time represented in the schedule.

(b) If a schedule format is not specified elsewhere in the Contract Documents, the construction schedule shall be prepared using Alabama Building Commission (ABC) Form C-11, "Progress Schedule and Report", or similar format of suitable scale and detail to indicate the percentage of Work scheduled to be completed at the end of each month. At the end of each month the Contractor shall enter the actual percentage of completion on the construction schedule submit two copies to the Owner, and attach one copy to each copy of the monthly Application for Payment. The construction schedule shall be revised to reflect any agreed extensions of the Contract Time or as required by conditions of the Work.

(c) If a more comprehensive schedule format is specified elsewhere in the Contract Documents or voluntarily employed by the Contractor, ABC Form C-11 shall also be prepared, updated, and submitted as described in preceding Paragraph (b).

(d) The Contractor's construction schedule shall be used by the Contractor and Owner to determine the adequacy of the Contractor's progress. The Contractor shall be responsible for maintaining progress in accordance with the currently approved construction schedule and shall increase the number of shifts, and/or overtime operations, days of work, and/or the amount of construction plant and equipment as may be necessary to do so. If the Contractor's progress falls materially behind the currently approved construction schedule and, in the opinion of the Owner, the Contractor is not taking sufficient steps to regain schedule, the Owner may issue the Contractor a Notice to Cure pursuant to Section 3.27. In such a Notice to Cure the Owner may require the Contractor to submit such supplementary or revised construction schedules as may be deemed necessary to demonstrate the manner in which schedule will be regained.

3.13 EQUIPMENT, MATERIALS AND SUBSTITUTIONS.

(a) Every part of the Work shall be executed in a workmanlike manner in accordance with the Contract Documents and approved Submittals. All materials used in the Work shall be furnished in sufficient quantities to facilitate the proper and expeditious execution

of the Work and shall be new except such materials as may be expressly provided or allowed in the Contract Documents to be otherwise.

(b) Whenever a product, material, system, item of equipment, or service is identified in the Contract Documents by reference to a trade name, manufacturer's name, model number, etc. (hereinafter referred to as "source"), and only one or two sources are listed, or three or more sources are listed and followed by "or approved equal" or similar wording, it is intended to establish a required standard of performance, design, and quality, and the Contractor may submit, for the Owner's approval, products, materials, systems, equipment, or services of other sources which the Contractor can prove to the Owner's satisfaction are equal to, or exceed, the standard of performance, design and quality specified, unless the provisions of Paragraph (d) below apply. Such proposed substitutions are not to be purchased or installed without the Owner's written approval of the substitution.

(c) If the Contract Documents identify three or more sources for a product, material, system, item of equipment or service to be used and the list of sources is not followed by "or approved equal" or similar wording, the Contractor may make substitution only after evaluation by the Owner and execution of an appropriate Contract Change Order.

(d) If the Contract Documents identify only one source and expressly provide that it is an approved sole source for the product, material, system, item of equipment, or service, the Contractor must furnish the identified sole source.

3.14 SAFETY AND PROTECTION OF PERSONS AND PROPERTY.

(a) The Contractor shall be solely and completely responsible for conditions at the Project site, including safety of all persons (including employees) and property. The Contractor shall create, maintain, and supervise conditions and programs to facilitate and promote safe execution of the Work, and shall supervise the Work with the attention and skill required to assure its safe performance. Safety provisions shall conform to OSHA requirements and all other federal, state, county, and local laws, ordinances, codes, and regulations. Where any of these are in conflict, the more stringent requirement shall be followed.

(b) The Contractor shall employ Construction Methods, safety precautions, and protective measures that will reasonably prevent damage, injury or loss to:

- (i) Workers and other persons on the Project site and in adjacent and other areas that may be affected by the Contractor's operations;
- (ii) The Work and materials and equipment to be incorporated into the Work and stored by the Contractor on or off the Project site; and
- (iii) Other property on, or adjacent to, the Project site, including trees, shrubs, lawns, walks, pavements, roadways, structures, utilities, and other improvements not designated in the Contract Documents to be removed, relocated, or replaced.

(c) The Contractor shall be responsible for the prompt remedy of damage and loss to property, including the filing of appropriate insurance claims, caused in whole or in part by the fault or negligence of the Contractor, a Subcontractor, or anyone for whose acts they may be liable.

(d) The Contractor shall comply with and give notices required by applicable laws, ordinances, rules, regulations, and lawful orders of public authorities bearing on safety and protection of persons or property, including without limitation notices to adjoining property

owners of excavation or other construction activities that potentially could cause damage or injury to adjoining property or persons thereon.

(e) The Contractor shall erect and maintain barriers, danger signs, and any other reasonable safeguards and warnings against hazards as may be required for safety and protection during performance of the Contract and shall notify owners and users of adjacent sites and utilities of conditions that may exist or arise which may jeopardize their safety.

(f) If use or storage of explosives or other hazardous materials or equipment or unusual construction methods are necessary for execution of the Work, the Contractor shall exercise commensurate care and employ supervisors and workers properly qualified to perform such activity.

(g) The Contractor shall furnish a qualified safety representative at the Project site whose duties shall include the prevention of accidents. The safety representative shall be the Contractor's superintendent, unless the Contractor assigns this duty to another responsible member of its on-site staff and notifies the Owner in writing of such assignment.

(h) The Contractor shall not permit a load to be applied, or forces introduced, to any part of the construction or site that may cause damage to the construction or site or endanger safety of the construction, site, or persons on or near the site.

(i) The Contractor shall have the right to act as it deems appropriate in emergency situations jeopardizing life or property. The Contractor shall be entitled to equitable adjustment of the Contract Sum or Contract Time for its efforts expended for the sole benefit of the Owner in an emergency. Such adjustment shall be determined as provided in Sections 3.19 and 3.20.

3.15 HAZARDOUS MATERIALS.

(a) A Hazardous Material is any substance or material identified as hazardous under any federal, state, or local law or regulation, or any other substance or material which may be considered hazardous or otherwise subject to statutory or regulatory requirements governing its handling, disposal, and/or clean-up. Existing Hazardous Materials are Hazardous Materials discovered at the Project site and not introduced to the Project site by the Contractor, a Subcontractor, or anyone for whose acts they may be liable.

(b) If during the performance of the Work, the Contractor encounters a suspected Existing Hazardous Material, the Contractor shall immediately stop work in the affected area, take measures appropriate to the condition to keep people away from the suspected Existing Hazardous Material, and immediately notify the Owner of the condition in writing.

(c) The Owner shall obtain the services of an independent laboratory or professional consultant, appropriately licensed and qualified, to determine whether the suspected material is a Hazardous Material requiring abatement and, if so, to certify after its abatement that it has been rendered harmless. Any abatement of Existing Hazardous Materials will be the responsibility of the Owner. The Owner will advise the Contractor in writing of the persons or entities who will determine the nature of the suspected material and those who will, if necessary, perform the abatement. The Owner will not employ persons or entities to perform these services to whom the Contractor has reasonable objection.

(d) After certification by the Owner's independent laboratory or professional consultant that the material is harmless or has been rendered harmless, work in the affected area shall resume upon written agreement between the Owner and Contractor. If the material is found to be an Existing Hazardous Material and the Contractor incurs additional cost or delay due to

the presence and abatement of the material, the Contract Sum and/or Contract Time shall be appropriately adjusted by a Contract Change Order pursuant to Section 3.19.

(e) The Owner shall not be responsible for Hazardous Materials introduced to the Project site by the Contractor, a Subcontractor, or anyone for whose acts they may be liable unless such Hazardous Materials were required by the Contract Documents.

3.16 INSPECTION OF THE WORK.

(a) General

- (i) The Contractor is solely responsible for the Work's compliance with the Contract Documents. Therefore, the Contractor shall be responsible to inspect in-progress and completed Work, and shall verify its compliance with the Contract Documents and that any element or portion of the Work upon which subsequent Work is to be applied or performed is in proper condition to receive the subsequent Work. Neither the presence nor absence of inspections by the Owner, any public authority having jurisdiction, or their representatives shall relieve the Contractor of responsibility to inspect the Work, for responsibility for Construction Methods and safety precautions and programs in connection with the Work, or from any other requirement of the Contract Documents.
- (ii) The Owner, any public authority having jurisdiction, and their representatives shall have access at all times to the Work for inspection whenever it is in preparation or progress, and the Contractor shall provide proper facilities for such access and inspection. All materials, workmanship, processes of manufacture, and methods of construction, if not otherwise stipulated in the Contract Documents, shall be subject to inspection, examination, and test at any and all places where such manufacture and/or construction are being carried on. Such inspections will not unreasonably interfere with the Contractor's operations.
- (iii) The Contractor may be charged by the Owner for any extra cost of inspection incurred by the Owner on account of material and workmanship not being ready at the time of inspection set by the Contractor.

(b) Types of Inspections

- (i) **Scheduled Inspections and Conferences;** Scheduled Inspections and Conferences are conducted by the Owner, scheduled by the Owner in coordination with the Contractor and are attended by the Contractor and applicable Subcontractors, suppliers and manufacturers. Scheduled Inspections and Conferences of this Contract include:
 - (1) **Pre-construction Conference.**
 - (2) **Final Inspection(s):** A Final Inspection shall establish that the Work, or a designated portion of the Work, is Substantially Complete in accordance with Section 3.32 and is accepted by the Owner as being ready for the

Owner's occupancy or use. At the conclusion of this inspection, items requiring correction or completion ("punch list" items) shall be minimal and require only a short period of time for accomplishment to establish Final Acceptance of the Work. If the Work, or designated portion of the Work, includes the installation, or modification, of a fire alarm system or other life safety systems essential to occupancy, such systems shall have been tested and appropriately certified before the Final Inspection.

- (3) **Year-end Inspection(s):** An inspection of the Work or each separately completed portion thereof, is required near the end of the Contractor's one year warranty period(s). The subsequent delivery of the report of this inspection will serve as confirmation that the Contractor was notified of Defective Work found within the warranty period in accordance with Section 3.35.
 - (ii) **Periodic Inspections.** Periodic Inspections are conducted throughout the course of the Work by the Owner, the Owner's consultants, and their representatives, jointly or independently, with or without advance notice to the Contractor.
 - (iii) **Specified Inspections and Tests.** Specified Inspections and Tests include inspections, tests, demonstrations, and approvals that are either specified in the Contract Documents or required by laws, ordinances, rules, regulations, or orders of public authorities having jurisdiction, to be performed by the Contractor, one of its Subcontractors, or an independent testing laboratory or firm (whether paid for by the Contractor or Owner).
- (c) **Uncovering Work.**
- (i) If the Contractor covers a portion of the Work before it is examined by the Inspector and this is contrary to the Owner's request or specific requirements in the Contract Documents, then, upon written request of the Owner, the Work must be uncovered for the Inspector's examination and be replaced at the Contractor's expense without change in the Contract Time.
 - (ii) Without a prior request or specific requirement that Work be examined by the Inspector before it is covered, the Inspector may request that Work be uncovered for examination and the Contractor shall uncover it. If the Work is in accordance with the Contract Documents, the Contract Sum shall be equitably adjusted under Section 3.19 to compensate the Contractor for the costs of uncovering and replacement. If the Work is not in accordance with the Contract Documents, uncovering, correction, and replacement shall be at the Contractor's expense unless the condition was caused by the Owner or a separate contractor in which event the Owner shall be responsible for payment of such costs.

(d) Specified Inspections and Tests.

- (i) The Contractor shall schedule and coordinate Specified Inspections and Tests to be made at appropriate times so as not to delay the progress of the Work or the work of the Owner or separate contractors. If the Contract Documents require that a Specified Inspection or Test be witnessed or attended by the Owner's Representative, the Contractor shall give the Owner timely notice of the time and place of the Specified Inspection or Test. If a Specified Inspection or Test reveals that Work is not in compliance with requirements of the Contract Documents, the Contractor shall bear the costs of correction, repeating the Specified Inspection or Test, and any related costs incurred by the Owner. Through appropriate Contract Change Order the Owner shall bear costs of tests, inspections or approvals which become Contract requirements subsequent to the receipt of bids.
- (ii) If the Owner or public authority having jurisdiction determines that inspections, tests, demonstrations, or approvals in addition to Specified Inspections and Tests are required, the Contractor shall, upon written instruction from the Owner, arrange for their performance by an entity acceptable to the Owner, giving timely notice to the Owner of the time and place of their performance. Related costs shall be borne by the Owner unless the procedures reveal that Work is not in compliance with requirements of the Contract Documents, in which case the Contractor shall bear the costs of correction, repeating the procedures, and any related costs incurred by the Owner.
- (iii) Unless otherwise required by the Contract Documents, required certificates of Specified Inspections and Tests shall be secured by the Contractor and promptly delivered to the Owner.
- (iv) Failure of any materials to pass Specified Inspections and Tests will be sufficient cause for refusal to consider any further samples of the same brand or make of that material for use in the Work.

3.17 CORRECTION OF DEFECTIVE WORK.

(a) The Contractor shall, at the Contractor's expense, promptly correct Defective Work rejected by the Owner or which otherwise becomes known to the Contractor, removing the rejected or nonconforming materials and construction from the project site.

(b) Correction of Defective Work shall be performed in such a timely manner as will avoid delay of completion, use, or occupancy of the Work and the work of the Owner and separate contractors.

(c) The Contractor shall bear all expenses related to the correction of Defective Work, including but not limited to:

- (i) Additional testing and inspections, including repeating specified inspections and tests,
- (ii) Reasonable services and expenses of the Owner, and

- (iii) The expense of making good all work of the Contractor, Owner, or separate contractors destroyed or damaged by the correction of Defective Work.

3.18 DEDUCTIONS FOR UNCORRECTED WORK. If the Owner deems it advisable and in the Owner's interest to accept Defective Work, the Owner may allow part or all of such Work to remain in place, provided an equitable deduction from the Contract Sum, acceptable to the Owner, is offered by the Contractor.

3.19 CHANGES IN THE WORK.

(a) General.

- (i) The Owner may at any time direct the Contractor to make changes in the Work which are within the general scope of the Contract, including changes in the Drawings, Specifications, or other portions of the Contract Documents to add, delete, or otherwise revise portions of the Work.
- (ii) If the Owner directs a change in the Work, the change shall be incorporated into the Contract by a Contract Change Order prepared by the Owner and signed by the Contractor, Owner, and other signatories to the Construction Contract, stating their agreement upon the change or changes in the Work and the adjustments, if any, in the Contract Sum and the Contract Time.
- (iii) In the event of a claim or dispute as to the appropriate adjustment to the Contract Sum or Contract Time due to a directive to make changes in the Work, the Work shall proceed as provided in this section subject to subsequent agreement of the parties or final resolution of the dispute pursuant to Section 3.24.
- (iv) Consent of surety will be obtained from all Contract Change Orders involving an increase in the Contract Sum.
- (v) Changes in the Work shall be performed under applicable provisions of the Contract Documents and the Contractor shall proceed promptly to perform changes in the Work, unless otherwise directed by the Owner.

(b) Determination of Adjustment of the Contract Sum. The adjustment of the Contract Sum resulting from a change in the Work shall be determined by one of the following methods, or a combination thereof, as selected by the Owner:

- (i) **Lump Sum.** By mutual agreement to a lump sum based on or negotiated from an itemized cost proposal from the Contractor. Additions to the Contract Sum shall include the Contractor's direct costs plus a maximum 15% markup for overhead and profit. Where subcontract work is involved the total mark-up for the Contractor and a Subcontractor shall not exceed 25%. No allowance for overhead and profit shall be figured on a change which involves a net credit to the Owner. For the purposes of this method of determining an adjustment of the Contract Sum,

“overhead” shall cover the Contractor’s indirect costs of the change, such as the cost of bonds, superintendent and other job office personnel, watchman, job office, job office supplies and expenses, temporary facilities and utilities, and home office expenses.

- (ii) **Unit Price.** By application of Unit Prices included in the Contract or subsequently agreed to by the parties. However, if the character or quantity originally contemplated is materially changed so that application of such unit price to quantities of Work proposed will cause substantial inequity to either party, the applicable unit price shall be equitably adjusted.
- (iii) **Force Account.** By directing the Contractor to proceed with the change in the Work on a “force account” basis under which the Contractor shall be reimbursed for reasonable expenditures incurred by the Contractor and its Subcontractors in performing added Work and the Owner shall receive reasonable credit for any deleted Work. The Contractor shall keep and present, in such form as the Owner may prescribe, an itemized accounting of the cost of the change together with sufficient supporting data. Unless otherwise stated in the directive, the adjustment of the Contract Sum shall be limited to the following:
 - (1) Costs of labor and supervision, including employee benefits, social security, retirement, unemployment and workers’ compensation insurance required by law, agreement, or under Contractor’s or Subcontractor’s standard personnel policy;
 - (2) Cost of materials, supplies, and equipment, including cost of delivery, whether incorporated or consumed;
 - (3) Rental cost of machinery and equipment, not to exceed prevailing local rates if contractor-owned;
 - (4) Costs of premiums for insurance required by the Contract Documents, permit fees, and sales, use or similar taxes related to the change in the Work;
 - (5) Reasonable credits to the Owner for the value of deleted Work, without Contractor or Subcontractor mark-ups; and
 - (6) For additions to the Contract Sum, mark-up of the Contractor’s direct costs for overhead and profit not exceeding 15% on Contractor’s work nor exceeding 25% for Contractor and Subcontractor on a Subcontractor’s work. No allowance for overhead and profit shall be figured on a change which involves a net credit to the Owner. For the purposes of this method of determining an adjustment of the Contract Sum, “overhead” shall cover the Contractor’s indirect costs of the change, such as the cost of insurance other than mentioned above, bonds, superintendent and other job office personnel, watchman,

use and rental of small tools, job office, job office supplies and expenses, temporary facilities and utilities, and home office expenses.

(c) Adjustment of the Contract Time Due to Changes.

- (i) Unless otherwise provided in the Contract Documents, the Contract Time shall be equitably adjusted for the performance of a change provided that the Contractor notifies the Owner in writing that the change will increase the time required to complete the Work. Such notice shall be provided no later than:
 - (1) With the Contractor's cost proposal stating the number of days of extension requested, or
 - (2) Within ten days after the Contractor receives a directive to proceed with a change in advance of submitting a cost proposal, in which case the notice should provide an estimated number of days of extension to be requested, which may be subject to adjustment in the cost proposal.

The Contract Time shall be extended only to the extent that the change affects the time required to complete the entire Work of the Contract, taking into account the concurrent performance of the changed and unchanged Work.

(d) Change Order Procedures.

- (i) If the Owner proposes to make a change in the Work, the Owner will request that the Contractor provide a cost proposal for making the change to the Work. The request shall be in writing and shall adequately describe the proposed change using drawings, specifications, narrative, or a combination thereof. Within 21 days after receiving such a request, or such other time as may be stated in the request, the Contractor shall prepare and submit to the Owner a written proposal, properly itemized and supported by sufficient substantiating data to facilitate evaluation. The stated time within which the Contractor must submit a proposal may be extended if, within that time, the Contractor makes a written request with reasonable justification thereof.
- (ii) The Contractor may voluntarily offer a change proposal which, in the Contractor's opinion, will reduce the cost of construction, maintenance, or operation or will improve the cost-effective performance of an element of the Project, in which case the Owner will accept, reject, or respond otherwise within 21 days after receipt of the proposal, or such other reasonable time as the Contractor may state in the proposal.
- (iii) If the Contractor's proposal is acceptable to the Owner, or is negotiated to the mutual agreement of the Contractor and Owner, the Owner will prepare an appropriate Contract Change Order for execution. Upon receipt of the fully executed Contract Change Order, the Contractor shall proceed with the change.

- (iv) If the Contractor and Owner cannot agree on the amount of the adjustment in the Contract Sum for a change, the Owner may order the Contractor to proceed with the change on a Force Account basis, but the net cost to the Owner shall not exceed the amount quoted in the Contractor's proposal. Such order shall state that funds are available to pay for the change.
- (v) If the Contractor does not promptly respond to a request for a proposal, or the Owner determines that the change is essential to the final product of the Work and that the change must be effected immediately to avoid delay of the Project, the Owner may determine with the Contractor a sufficient maximum amount to be authorized for the change and direct the Contractor to proceed with the change on a Force Account basis pending delivery of the Contractor's proposal, stating the maximum increase in the Contract Sum that is authorized for the change.
- (iv) Pending agreement of the parties or final resolution of any dispute of the total amount due the Contractor for a change in the Work, amounts not in dispute for such changes in the Work may be included in Applications for Payment accompanied by an interim Change Order indicating the parties' agreement with part of all of such costs or time extension. Once a dispute is resolved, it shall be implemented by preparation and execution of an appropriate Change Order.

3.20 CLAIMS FOR EXTRA COST OR EXTRA WORK.

(a) If the Contractor considers any instructions by the Owner, or public authority having jurisdiction to be contrary to the requirements of the Contract Documents and will involve extra work and/or cost under the Contract, the Contractor shall give the Owner written notice thereof within ten days after receipt of such instructions, and in any event before proceeding to execute such work. As used in this section, "instructions" shall include written or oral clarifications, directions, instructions, interpretations, or determinations.

(b) The Contractor's notification pursuant to Section 3.20. (a), shall state:

- (i) The date, circumstances, and source of the instructions,
- (ii) That the Contractor considers the instructions to constitute a change to the Contract Documents and why, and
- (iii) An estimate of extra cost and time that may be involved to the extent an estimate may be reasonably made at that time.

(c) Except for claims relating to an emergency endangering life or property, no claim for extra cost or extra work shall be considered in the absence of prior notice required under Section 3.20 (a).

(d) Within ten days of receipt of a notice pursuant to Section 3.20 (a), the Owner will respond in writing to the Contractor, stating one of the following:

- (i) The cited instruction is rescinded.
- (ii) The cited instruction is a change in the Work and in which manner the Contractor is to proceed with procedures of Section 3.19, Changes in the Work.

(iii) The cited instruction is reconfirmed, is not considered by the Owner to be a change in the Contract Documents, and the Contractor is to proceed with Work as instructed.

(e) If the Owner's response to the Contractor is as in Section 3.20 (d) (iii), the Contractor shall proceed with the Work as instructed. If the Contractor continues to consider the instructions to constitute a change in the Contract Documents, the Contractor shall, within ten days after receiving the Owner's response, notify the Owner in writing that the Contractor intends to submit a claim pursuant to Section 3.24, Resolution of Claims and Disputes.

3.21 DIFFERING SITE CONDITIONS.

(a) **Definition.** "Differing Site Conditions" are: Subsurface or otherwise concealed physical conditions at the Project site which differ materially from those indicated in the Contract Documents, or unknown physical conditions at the Project site which are of an unusual nature, differing materially from conditions ordinarily encountered and generally recognized as inherent in construction activities of the character required by the Contract Documents.

(b) **Procedures.** If Differing Site Conditions are encountered, then the party discovering the condition shall promptly notify the other party before the condition is disturbed and in no event later than ten days after discovering the condition. Upon such notice and verification that a Differing Site Condition exists, the Owner will, with reasonable promptness make changes in the Drawings and/or Specifications as are deemed necessary to conform to the Differing Site Condition. Any increase or decrease in the Contract Sum or Contract Time that is warranted by the changes will be made as provided under Section 3.19, Changes in the Work.

3.22 CLAIMS FOR DAMAGES. If either party to the Contract suffers injury or damage to person or property because of an act or omission of the other party, or of others for whose acts such party is legally responsible, written notice of such injury or damage, whether or not insured, shall be given to the other party within a reasonable time after the discovery. The notice shall provide sufficient detail to enable the other party to investigate the matter.

3.23 DELAYS.

(a) A delay beyond the Contractor's control at any time in the commencement or progress of Work by an act or omission of the Owner, or any separate contractor or by labor disputes, unusual delay in deliveries, unavoidable casualties, fires, abnormal floods, tornadoes, or other cataclysmic events of nature, may entitle the Contractor to an extension of the Contract Time provided, however, that the Contractor shall, within ten days after the delay first occurs, give written notice to the Owner of the cause of the delay and its probable effect on progress of the entire Work.

(b) Adverse weather conditions that are more severe than anticipated for the locality of the Work during any given month may entitle the Contractor to an extension of Contract Time provided, however;

(i) The weather conditions had an adverse effect on construction scheduled to be performed during the period in which the adverse weather occurred, which in reasonable sequence would have an effect on completion of the entire Work,

- (ii) The Contractor shall, within twenty-one days after the end of the month in which the delay occurs, give the Owner written notice of the delay that occurred during that month and its probable effect on progress of the Work, and
- (iii) Within a reasonable time after giving notice of the delay, the Contractor provides the Owner with sufficient data to document that the weather conditions experienced were unusually severe for the locality of the Work during the month in question. Unless otherwise provided in the Contract Documents, data documenting unusually severe weather conditions shall compare actual weather conditions to the average weather conditions for the month in question during the previous five years as recorded by the National Oceanic and Atmospheric Administration (NOAA) or similar record-keeping entities.

(c) Adjustments, if any, of the Contract Time pursuant to this Section shall be incorporated into the Contract by a Contract Change Order prepared by the Owner and signed by the Contractor, Owner, and other signatories to the Construction Contract or, at closeout of the Contract, by mutual written agreement between the Contractor and Owner. The adjustment of the Contract Time shall not exceed the extent to which the delay extends the time required to complete the entire Work of the Contract.

(d) The Contractor shall not be entitled to any adjustment of the Contract Sum for damage due to delays claimed pursuant to this Section unless the delay was caused by the Owner and was either:

- (i) The result of bad faith or active interference or
- (ii) Beyond the contemplation of the parties and not remedied within a reasonable time after notification by the Contractor of its presence.

3.24 RESOLUTION OF CLAIMS AND DISPUTES.

(a) Applicability of Section.

- (i) As used in this section, "Claims and Disputes" include claims or disputes asserted by the Contractor, its Surety, or Owner arising out of or related to the Contract, or its breach, including without limitation claims seeking, under the provisions of the Contract, equitable adjustment of the Contract Sum or Contract Time and claims and disputes arising between the Contractor (or its Surety) and Owner regarding interpretation of the Contract Documents, performance of the Work, or breach of or compliance with the terms of the Contract.
- (ii) "Resolution" addressed in this Section applies only to Claims and Disputes arising between the Contractor (and its Surety) and Owner and asserted after execution of the Construction Contract and prior to the date upon which final payment is made. Upon making application for final payment the Contractor may reserve the right to subsequent Resolution of existing Claims by including a list of all Claims, in stated amounts, which remain to be resolved and specifically excluding them from any release of claims

executed by the Contractor, and in that event Resolution may occur after final payment is made.

(b) **Continuance of Performance.** An unresolved Claim or Dispute shall not be just cause for the Contractor to fail or refuse to proceed diligently with performance of the Contract or for the Owner to fail or refuse to continue to make payments in accordance with the Contract Documents.

(c) **Good Faith Effort to Settle.** The Contractor and Owner agree that, upon the assertion of a Claim by the other, they will make a good faith effort to achieve mutual resolution of the Claim. If mutually agreed, the Contractor and Owner may endeavor to resolve a Claim through mediation. If efforts to settle are not successful, the Claim shall be resolved in accordance with paragraph (d).

(d) **Final Resolution for Locally-Funded Contracts.** If the Contract is funded in whole with funds provided by a local governmental authority and the Contract Documents do not stipulate a binding alternative dispute resolution method, the final resolution of Claims and Disputes which cannot be resolved by the Contractor (or its Surety) and Owner may be by any legal remedy available to the parties. Alternatively, upon the written agreement of the Contractor and the Owner, final Resolution of Claims and Disputes may be by submission to binding arbitration before a neutral arbitrator or panel.

3.25 OWNER'S RIGHT TO CORRECT DEFECTIVE WORK. If the Contractor fails or refuses to correct Defective Work in a timely manner that will avoid delay of completion, use, or occupancy of the Work or work by the Owner or separate contractors, the Owner may give the Contractor written Notice to Cure the Defective Work within a reasonable, stated time. If within ten days after receipt of the Notice to Cure the Contractor has not proceeded and satisfactorily continued to cure the Defective Work or provided the Owner with written verification that satisfactory positive action is in process to cure the Defective Work, the Owner may, without prejudice to any other remedy available to the Owner, correct the Defective Work and deduct the actual cost of the correction from payment then or thereafter due to the Contractor.

3.26 OWNER'S RIGHT TO STOP OR SUSPEND THE WORK.

(a) **Stopping the Work for Cause.** If the Contractor fails to correct Defective Work or persistently fails to carry out Work in accordance with the Contract Documents, the Owner may direct the Contractor in writing to stop the Work, or any part of the Work, until the cause for the Owner's directive has been eliminated; however, the Owner's right to stop the Work shall not be construed as a duty of the Owner to be exercised for the benefit of the Contractor or any other person or entity.

(b) **Suspension by the Owner for Convenience.**

- (i) The Owner may, at any time and without cause, direct the Contractor in writing to suspend, delay or interrupt the Work, or any part of the Work, for a period of time as the Owner may determine.
- (ii) The Contract Sum and Contract Time shall be adjusted, pursuant to Section 3.19, for reasonable increases in the cost and time caused by an Owner-directed suspension, delay or interruption of Work for the Owner's convenience. However, no adjustment to the

Contract Sum shall be made to the extent that the same or concurrent Work is, was or would have been likewise suspended, delayed or interrupted for other reasons not caused by the Owner.

3.27 OWNER'S RIGHT TO TERMINATE CONTRACT.

(a) Termination by the Owner for Cause.

(i) **Causes:** The Owner may terminate the Contractor's right to complete the Work, or any designated portion of the Work, if the Contractor:

- (1) Should be adjudged bankrupt, or should make a general assignment for the benefit of the Contractor's creditors, or if a receiver should be appointed on account of the Contractor's insolvency to the extent termination for these reasons is permissible under applicable law;
- (2) Refuses or fails to prosecute the Work, or any part of the Work, with the diligence that will insure its completion within the Contract Time, including any extensions, or fails to complete the Work within the Contract Time;
- (3) Refuses or fails to perform the Work, including prompt correction of Defective Work, in a manner that will insure that the Work, when fully completed, will be in accordance with the Contract Documents;
- (4) Fails to pay for labor or materials supplied for the Work or to pay Subcontractors in accordance with the respective Subcontract;
- (5) Persistently disregards laws, ordinances, or rules, regulations or orders of a public authority having jurisdiction, or the instructions of the Owner; or
- (6) Is otherwise guilty of a substantial breach of the Contract.

(ii) **Procedure for Unbonded Construction Contracts** (Generally, contracts less than \$50,000):

- (1) **Notice to Cure:** In the presence of any of the above conditions the Owner may give the Contractor written notice to cure the condition within a reasonable, stated time, but not less than ten days after the Contractor receives the notice.
- (2) **Notice of Termination:** If, at the expiration of the time stated in the Notice to Cure, the Contractor has not proceeded and satisfactorily continued to cure the condition or provided the Owner with written verification that satisfactory positive action is in process to cure the condition, the Owner may, without prejudice to any other rights or remedies of the Owner, give the Contractor written notice that the Contractor's right to complete the Work, or a designated portion of the Work, shall terminate

seven days after the Contractor's receipt of the written Notice of Termination.

- (3) If the Contractor satisfies a Notice to Cure, but the condition for which the notice was first given reoccurs, the Owner may give the Contractor a seven day Notice of Termination without giving the Contractor another Notice to Cure.
 - (4) At the expiration of the seven days of the termination notice, the Owner may:
 - a. take possession of the site, of all materials and equipment stored on and off site, and of all Contractor-owned tools, construction equipment and machinery, and facilities located at the site, and
 - b. finishes the Work by whatever reasonable method the Owner may deem expedient.
 - (5) The Contractor shall not be entitled to receive further payment under the Contract until the Work is completed.
 - (6) If the Owner's cost of completing the Work, including correction of Defective Work, compensation for additional architectural, engineering, managerial, and administrative services, and reasonable attorneys' fees due to the default and termination, is less than the unpaid balance of the Contract Sum, the excess balance less liquidated damages for delay shall be paid to the Contractor. If such cost to the Owner including attorney's fees, plus liquidated damages, exceeds the unpaid balance of the Contract Sum, the Contractor shall pay the difference to the Owner. Final Resolution of any claim or Dispute involving the termination or any amount due any party as a result of the termination shall be pursuant to Section 3.24.
 - (7) Upon the Contractor's request, the Owner shall furnish to the Contractor a detailed accounting of the Owner's cost of completing the Work.
- (iii) **Procedure for Bonded Construction Contracts** (Generally, contracts over \$50,000):
- (1) **Notice to Cure:** In the presence of any of the above conditions the Owner may give the Contractor and its Surety written Notice to Cure the condition within a reasonable, stated time, but not less than ten days after the Contractor receives the notice.
 - (2) **Notice of Termination:** If, at the expiration of the time stated in the Notice to Cure, the Contractor has not proceeded and satisfactorily continued to cure the condition or provided the Owner with written verification that satisfactory positive action is in process to cure the condition, the Owner may, without prejudice to any other

- rights or remedies of the Owner, give the Contractor and its Surety written notice declaring the Contractor to be in default under the Contract and stating that the Contractor's right to complete the Work, or a designated portion of the Work, shall terminate seven days after the Contractor's receipt of the written Notice of Termination.
- (3) If the Contractor satisfies a Notice to cure, but the condition for which the notice was first given reoccurs, the Owner may give the Contractor a Notice of Termination without giving the Contractor another Notice to Cure.
 - (4) **Demand on the Performance Bond:** With the Notice of Termination the Owner shall give the Surety a written demand that, upon the effective date of the Notice of Termination, the Surety promptly fulfill its obligation to take charge of and complete the Work in accordance with the terms of the Performance Bond.
 - (5) **Surety Claims:** Upon receiving the Owner's demand on the Performance Bond, the Surety shall assume all rights and obligations of the Contractor under the Contract. However, the Surety shall also have the right to assert "Surety Claims" to the Owner, which are defined as claims relating to acts or omissions of the Owner prior to termination of the Contractor which may have prejudiced its rights as Surety or its interest in the unpaid balance of the Contract Sum. If the Surety wishes to assert a Surety Claim, it shall give the Owner written notice within twenty-one days after first recognizing the condition giving rise to the Surety Claim. The Surety Claim shall then be submitted to the Owner no later than sixty days after giving notice thereof, but no such Surety Claims shall be considered if submitted after the date upon which final payment becomes due. Final resolution of Surety Claims shall be pursuant to Section 3.24, Resolution of Claims and Disputes. The presence or possibility of a Surety Claim shall not be just cause for the Surety to fail or refuse to take charge of and complete the Work or for the Owner to fail or refuse to continue to make payments in accordance with the Contract Documents.
 - (6) **Payments to Surety:** The Surety shall be paid for completing the Work in accordance with the Contract Documents as if the Surety were the Contractor. The Owner shall have the right to deduct from payments to the Surety any reasonable costs incurred by the Owner, including compensation for additional architectural, engineering, managerial, and administrative services, and attorneys' fees as necessitated by termination of the

Contractor and completion of the Work by the Surety. No further payments shall be made to the Contractor by the Owner. The Surety shall be solely responsible for any accounting to the Contractor for the portion of the Contract Sum paid to Surety by Owner or for the costs and expenses of completing the Work.

- (iv) **Wrongful Termination:** If any notice of termination by the Owner for cause, made in good faith, is determined to have been wrongly given, such termination shall be effective and compensation therefore determined as if it had been a termination for convenience pursuant to Paragraph (b) below.

(b) Termination by the Owner for Convenience.

- (i) The Owner may, without cause and at any time, terminate the performance of Work under the Contract in whole, or in part, upon determination by the Owner that such termination is in the Owner's best interest. Such termination is referred to herein as Termination for Convenience.
- (ii) Upon receipt of a written notice of Termination for Convenience from the Owner, the Contractor shall:
 - (1) Stop Work as specified in the notice;
 - (2) Enter into no further subcontracts or purchase orders for materials, services, or facilities, except as may be necessary for Work directed to be performed prior to the effective date of the termination or to complete Work that is not terminated;
 - (3) Terminate all existing subcontracts and purchase orders to the extent they relate to the terminated Work;
 - (4) Take such actions as are necessary, or directed by the Owner, to protect, preserve, and make safe the terminated Work; and
 - (5) Complete performance of the Work that is not terminated.
- (iii) In the event of Termination for Convenience, the Contractor shall be entitled to receive payment for the Work performed prior to its termination, including materials and equipment purchased and delivered for incorporation into the terminated Work, and any reasonable costs incurred because of the termination. Such payment shall include reasonable mark-up of costs for overhead and profit, not to exceed the limits stated in Section 3.19, Changes in the Work. The Contractor shall be entitled to receive payment for reasonable anticipated overhead ("home office") and shall not be entitled to receive payment for any profits anticipated to have been gained from the terminated Work. A proposal for decreasing the Contract Sum shall be submitted to the Owner by the Contractor in such time and detail, and with such supporting documentation, as is reasonably directed by the Owner. Final modification of the Contract shall be by Contract Change Order

pursuant to Section 3.19. Any Claim or Dispute involving the termination or any amount due a party as a result shall be resolved pursuant to Section 3.24.

3.28 CONTACTOR'S RIGHT TO SUSPEND OR TERMINATE THE CONTRACT.

(a) **Suspension by the Owner.** If all of the Work is suspended or delayed for the Owner's convenience or under an order of any court, or other public authority, for a period of sixty days, through no act or fault of the Contractor or a Subcontractor, or anyone for whose acts they may be liable, then the Contractor may give the Owner a written Notice of Termination which allows the Owner fourteen days after receiving the Notice in which to give the Contractor appropriate written authorization to resume the Work. Absent the Contractor's receipt of such authorization to resume the Work, the Contract shall terminate upon expiration of this fourteen day period and the Contractor will be compensated by the Owner as if the termination had been for the Owner's convenience pursuant to Section 3.27 (b).

(b) **Nonpayment.** The Owner's failure to pay the undisputed amount of an Application for Payment within sixty days after receiving it from the Owner shall be just cause for the Contractor to give the Owner fourteen days' written notice that the Work will be suspended pending receipt of payment but that the Contract shall terminate if payment is not received within fourteen days (or a longer period stated by the Contractor) of the expiration of the fourteen day notice period.

- (i) If the Work is then suspended for nonpayment, but resumed upon receipt of payment, the Contractor will be entitled to compensation as if the suspension had been by the Owner pursuant to Section 3.26, paragraph (b).
- (ii) If the Contract is then terminated for nonpayment, the Contractor will be entitled to compensation as if the termination had been by the Owner pursuant to Section 3.27, Paragraph (b).

3.29 PROGRESS PAYMENTS.

(a) **Frequency of Progress Payments.** Unless otherwise provided in the Contract Documents, the Owner will make payments to the Contractor as the Work progresses based on estimates prepared and certified by the Contractor at the end of each calendar month and approved by the Owner and other authorities whose approval is required.

(b) **Designation of Owner's Representative.** All progress payments and associated documentation shall be submitted to the Owner's Representative for review, approval, and certification as per Section 3.30.

(c) **Schedule Values.** Within ten days after receiving the Notice to Proceed the Contractor shall submit to the Owner a Schedule of Values, which is a breakdown of the Contract Sum showing the value of the various parts of the Work for billing purposes, in a format acceptable to the Owner. The Schedule of Values shall divide the Contract Sum into as many parts ("line items") as the Owner determines to be necessary to permit evaluation and to show amounts attributable to Subcontractors. The Contractor's overhead and profit are to be proportionately distributed throughout the line items of the Schedule of Values. Upon approval, the Schedule of Values shall be used as a basis for monthly Applications for Payment, unless it is

later found to be in error. Approved change order amounts shall be added to or incorporated into the Schedule of Values as mutually agreed by the Contractor and Owner.

(d) Application for Payments.

- (i) Based on the approved Schedule of Values, each monthly Application for Payment shall show the Contractor's estimate of the value of Work performed in each line item as of the end of the billing period. The Contractor's cost of materials and equipment not yet incorporated into the Work, but delivered and suitably stored on the site, may be considered in monthly Applications for Payment.
- (ii) The Contractor's estimate of the value of Work performed and stored materials must represent such reasonableness as to warrant certification by the Owner in accordance with Section 3.30. Each monthly Application for Payment shall be supported by such data as will substantiate the Contractor's right to payment, including without limitation copies of requisitions from subcontractors and material suppliers.
- (iii) If no other date is stated in the Contract Documents or agreed upon by the parties, each monthly Application for Payment shall be submitted to the Owner on or about the first day of each month and payment shall be issued to the Contractor within thirty five (35) days after an Application for Payment is certified pursuant to Section 3.30.

(e) Materials Stored Off Site. Unless otherwise provided in the Contract Documents, the Contractor's cost of materials and equipment to be incorporated into the Work, which are stored off the site, may also be considered in monthly Applications for Payment under the following conditions:

- (i) The contractor has received written approval from the Owner to store the materials or equipment off site in advance of delivering the materials to the off site location;
- (ii) A Certificate of Insurance is furnished to the Owner evidencing that a special insurance policy, or rider to an existing policy, has been obtained by the Contractor providing all-risk property insurance coverage, specifically naming the materials or equipment stored, and naming the Owner as an additionally insured party;
- (iii) The Owner is provided with a detailed inventory of the stored materials or equipment and the materials or equipment are clearly marked in correlation to the inventory to facilitate inspection and verification of the presence of the materials or equipment by the Owner;
- (iv) The materials or equipment are properly and safely stored in a bonded warehouse, or a facility otherwise approved in advance by the Owner; and
- (v) Compliance by the Contractor with procedures satisfactory to the Owner to establish the Owner's title to such materials and equipment or otherwise protect the Owner's interest.

(f) Retainage.

- (i) "Retainage" is defined as the money earned and, therefore, belonging to the Contractor (subject to final settlement of the Contract) which has been retained by the Owner conditioned on final completion and acceptance of all Work required by the Contract Documents. Retainage shall not be relied upon by Contractor (or Surety) to cover or off-set unearned monies attributable to uncompleted or uncorrected Work.
- (ii) In making progress payments the Owner shall retain five percent of the estimated value of Work performed and the value of the materials stored for the Work; but after retainage has been held upon fifty percent of the Contract Sum, no additional retainage will be withheld.

(g) Contractor's Certification.

- (i) Each Application for Payment shall bear the Contractor's notarized certification that, to the best of the Contractor's knowledge, information, and belief, the Work covered by the Application for Payment has been completed in accordance with the Contract Documents, that all amounts have been paid by the Contractor for Work for which previous Certificates for Payments were issued and payments received from the Owner and that the current payment shown in the Application for Payment has not yet been received.
- (ii) By making this certification the Contractor represents to the Owner that, upon receipt of previous progress payments from the Owner, the Contractor has promptly paid each Subcontractor, in accordance with the terms of its agreement with the Subcontractor, the amount due the Subcontractor from the amount included in the progress payment on account of the Subcontractor's Work and stored materials. The Owner may advise Subcontractors and suppliers regarding percentages of completion or amounts requested and/or approved in an Application for Payment on account of the Subcontractor's Work and stored materials.

(h) Payment Established Ownership. All material and Work covered by progress payments shall become the sole property of the Owner, but the Contractor shall not be relieved from the sole responsibility for the care and protection of material and Work upon which payments have been made and for the restoration of any damaged material and Work.

3.30 CERTIFICATION AND APPROVALS FOR PAYMENT.

(a) The Owner's review, approval, and certification of Applications for Payment shall be conducted by the Owner's Representative. The Owner's Representative's review, approval, and certification of Applications for Payment shall be based on the Owner's Representative's general knowledge of the Work obtained through site visits and the information provided by the Contractor with the Application. The Owner's Representative shall not be required to perform exhaustive examinations, evaluations, or estimates of the cost of completed or uncompleted Work or stored materials to verify the accuracy of amounts requested by the

Contractor, but the Owner's Representative shall have the authority to adjust the Contractor's estimate when, in the Owner's Representative's reasonable opinion, such estimates are overstated or understated.

(b) Within ten (10) days after receiving the Contractor's monthly Application for Payment, or such other time as may be stated in the Contract Documents, the Owner's Representative will take one of the following actions:

- (i) The Owner's Representative will approve and certify the Application as submitted and forward for payment.
- (ii) If the Owner's Representative takes exception to any amounts claimed by the Contractor and the Contractor and Owner's Representative cannot agree on revised amounts, the Owner's representative will promptly issue a Certificate for Payment for the amount for which the Owner's Representative is able to certify, transmitting a copy of same to the Contractor.
- (iii) To the extent the Owner's Representative determines may be necessary to protect from loss on account of any of the causes stated in Section 3.31, the Owner's Representative may subtract from the Contractor's estimates and will issue a Certificate for Payment with a copy to the Contractor, for such amount as the Owner's Representative determines is properly due and notify the Contractor in writing of the reasons for withholding payment in whole or in part.

(c) Neither the Owner's Representative's issuance of a Certificate for Payment nor the Owner's resulting progress payment shall be a representation to the Contractor that the Work in progress or completed at that time is accepted or deemed to be in conformance with the Contract Documents.

(d) The Owner's Representative shall not be required to determine that the Contractor has promptly or fully paid Subcontractors and suppliers or how or for what purpose the Contractor has used monies paid under the Construction Contract. However, the Owner's Representative may, upon request and if practical, inform any Subcontractor or supplier of the amount, or percentage of completion, approved or paid to the Contractor on account of the materials supplied or the Work performed by the Subcontract.

3.31 PAYMENTS WITHHELD.

(a) The Owner may nullify or revise a previously issued Certificate for payment prior to Owner's payment there under to the extent as may be necessary in the Owner's opinion to protect the Owner from loss on account of any of the following causes not discovered or fully accounted for at the time of the certification or approval of the Application for Payment:

- (i) Defective Work;
- (ii) Filed, or reasonable evidence indicating probable filing of, claims arising out of the Contract by other parties against the Contractor;
- (iii) The Contractor's failure to pay for labor, materials or equipment or to pay Subcontractors;
- (iv) Reasonable evidence that the Work cannot be completed for the unpaid balance of the Contract Sum;

- (v) Damage suffered by the Owner or another contractor caused by the Contractor, a Subcontractor, or anyone for whose acts they may be liable;
- (vi) Reasonable evidence that the Work will not be completed within the Contract Time, and that the unpaid balance is insufficient to cover applicable liquidated damages; or
- (vii) The Contractor's persistent failure to conform to the requirements of the Contract Documents.

(b) If the Owner deems it necessary to withhold payment pursuant to preceding Paragraph (a), the Owner will notify the Contractor in writing of the amount to be withheld and the reason for same.

(c) The Owner shall not be required to withhold payment for completed or partially completed Work for which compliance with the Contract Documents remains to be determined by Specified Inspections or Final Inspections to be performed in their proper sequence. However, if Work for which payment has been approved, certified, or made under an Application for Payment is subsequently determined to be Defective Work, the Owner shall determine an appropriate amount that will protect the Owner's interest against the Defective Work.

- (i) If payment has not been made against the Application for Payment first including the Defective Work, the Owner will notify the Contractor of the amount to be withheld from the payment until the Defective Work is brought into compliance with the Contract Documents.
- (ii) If payment has been made against the Application for Payment first including the Defective Work, the Owner will withhold the appropriate amount from the next Application for Payment submitted after the determination of noncompliance, such amount to then be withheld until the Defective Work is brought into compliance with the Contract Documents.

(d) The amount withheld will be paid with the next Application for Payment certified and approved after the condition for which the Owner has withheld payment is removed or otherwise resolved to the Owner's satisfaction.

(e) The Owner shall have the right to withhold from payments due the Contractor under this Contract an amount equal to any amount which the Contractor owes the Owner under another contract.

3.32 SUBSTANTIAL COMPLETION.

(a) Substantial Completion is the stage in the progress of the Work when the Work or designated portion of the Work is sufficiently complete in accordance with the Contract Documents so that the Owner can occupy or utilize the Work for its intended use without disruption or interference by the Contractor in completing or correcting any remaining unfinished Work ("punch list" items). Substantial Completion of the Work, or a designated portion of the Work, is not achieved until so agreed in a Certificate of Substantial Completion signed by the Contractor and Owner.

(b) The Contractor shall notify the Owner in writing when it considers the Work, or a portion of the Work which the Owner has agreed to accept separately, to be

substantially complete and ready for a Final Inspection pursuant to Section 3.16. In this notification the Contractor shall identify any items remaining to be completed or corrected for Final Acceptance prior to final payment.

(c) Substantial Completion is achieved and a Final Inspection is appropriate only when a minimal number of punch list items exists and only a short period of time will be required to correct or complete them. Upon receipt of the Contractor's notice for a Final Inspection, the Owner will advise the Contractor in writing of any conditions of the Work which the Owner is aware do not constitute Substantial Completion; otherwise, a Final Inspection will proceed within a reasonable time after the Contractor's notice is given. However, the Owner will not be required to prepare lengthy listings of punch list items; therefore, if the Final Inspection discloses that Substantial Completion has not been achieved, the Owner may discontinue or suspend the inspection until the Contractor does achieve Substantial Completion.

(d) Certificate of Substantial Completion.

- (i) When the Work or a designated portion of the Work is substantially complete, the Owner will prepare and sign a Certificate of Substantial Completion to be signed in order by the Contractor, and Owner.
- (ii) When signed by all parties, the Certificate of Substantial Completion shall establish the Date of Substantial Completion which is the date upon which:
 - (1) The Work, or designated portion of the Work, is accepted by the Owner as being ready for occupancy,
 - (2) The Contractor's one-year and special warranties for the Work covered by the Certificate commence, unless stated otherwise in the Certificate (the one-year warranty for punch list items completed or corrected after the period allowed in the Certificate shall commence on the date of their Final Acceptance) , and
 - (3) Owner becomes responsible for building security, maintenance, utility services, and insurance, unless stated otherwise in the Certificate.
- (iii) The Certificate of Substantial Completion shall set the time within which the Contractor shall finish all items on the "punch list" accompanying the Certificate. The completion of punch list items shall be a condition precedent to Final Payment.

(e) The Date of Substantial Completion of the Work, as set in the Certificate of Substantial Completion of the Work or of the last completed portion of the Work, establishes the extent to which the Contractor is liable for Liquidated Damages, if any; however, should the Contractor fail to complete all punch list items within thirty days, or such other time as may be stated in the respective Certificate of Substantial Completion, the Contractor shall bear any expenses incurred by the Owner as a result of such failure to complete punch list items in a timely manner.

3.33 OCCUPANCY OR USE PRIOR TO COMPLETION.

(a) **Upon Substantial Completion.** Prior to completion of the entire Work, the Owner may occupy or begin utilizing any designated portion of the Work on the agreed Date of Substantial Completion of that portion of the Work.

(b) **Before Substantial Completion.**

- (i) The Owner shall not occupy or utilize any portion of the Work before Substantial Completion of that portion has been achieved.
- (ii) The Owner may deliver furniture and equipment and store, or install it in place ready for occupancy and use, in any designated portion of the Work before it is substantially completed under the following conditions:
 - (1) The Owner's storage or installation of furniture and equipment will not unreasonably disrupt or interfere with the Contractor's completion of the designated portion of the Work.
 - (2) The Contractor consents to the Owner's planned action (such consent shall not be unreasonably withheld).
 - (3) The Owner shall be responsible for insurance coverage of the Owner's furniture and equipment, and the Contractor's liability shall not be increased.
 - (4) The Contractor and Owner will jointly inspect and record the condition of the Work in the area before the Owner delivers and stores or installs furniture and equipment; the Owner will equitably compensate the Contractor for making any repairs to the Work that may subsequently be required due to the Owner's delivery and storage or installation of furniture and equipment.
 - (5) The Owner's delivery and storage or installation of furniture and equipment shall not be deemed an acceptance of any Work not completed in accordance with the requirements of the Contract Documents.

3.34 FINAL PAYMENT.

(a) **Prerequisites to Final Payment.** The following conditions are prerequisites to Final Payment becoming due the Contractor:

- (i) Full execution of a Certificate of Substantial Completion for the Work, or each designated portion of the Work.
- (ii) Final Acceptance of the Work.
- (iii) The Contractor's completion, to the satisfaction of Owner, of all documentary requirements of the Contract Documents; such as delivery of "as-built" documents, operating and maintenance manuals, warranties, etc.
- (iv) Delivery to the Owner of a final Application for Payment, prepared by the Contractor.
- (v) Completion of an Advertisement for Completion pursuant to Paragraph (c) below.

- (vi) Delivery by the Contractor to the Owner of a Release of Claims and such other documents as may be required by Owner, satisfactory in form to the Owner pursuant to Paragraph (d) below.
- (vii) Consent of Surety, if any, to Final Payment to Contractor.
- (viii) Delivery by the Contractor to the Owner of other documents, if any, required by the Contract Documents as prerequisites to Final Payment.

(b) **Final Acceptance of the Work.** “Final Acceptance of the Work” shall be achieved when all “punch list” items recorded with the Certificate(s) of Substantial Completion are accounted for by either:

- (i) Their completion or correction by the Contractor and acceptance by the Owner
- (ii) Their resolution under Section 3.18, Deductions for Uncorrected Work.

(c) **Advertisement for Completion.**

- (i) **If the Contract Sum is less than \$50,000:** The Owner, immediately after determining that all other requirements of the Contract have been completed, shall give public notice of completion of the Contract by having an Advertisement for Completion published one time in a newspaper of general circulation, published in the county in which the Owner is located and shall post notice of completion of the Contract on the Owner’s bulletin board for one week, and shall require the Contractor to certify under oath that all bills have been paid in full. Final payment may be made at any time after the notice has been posted for one entire week.
- (ii) **If the Contract Sum is more than \$50,000:** The Contractor, immediately after being notified by the Owner that all other requirements of the Contract have been completed, shall give public notice of completion of the Contract by having an Advertisement for Completion published for a period of four successive weeks in some newspaper of general circulation published within the city or county where the Work was performed. Proof of publication of the Advertisement for Completion, in duplicate, shall be made by the Contractor to the Owner by affidavit of the publisher and a printed copy of the Advertisement for Completion published, in duplicate. If no newspaper is published in the county where the work was done, the notice may be given by posting at the Court House for thirty days and proof of same made by Probate Judge or Sheriff and the Contractor. Final payment shall not be due until thirty days after this public notice is completed.

(d) **Release of Claims.** The Release of Claims and other documents referenced in Paragraph (a) (vi) above are as follows:

- (i) A release executed by Contractor of all claims and claims of lien against the Owner arising under and by virtue of the Contract,

other than such claims of the Contractor, if any, as may have been previously made in writing and as may be specifically excepted by the Contractor from the operation of the release in stated amounts to be set forth therein.

- (ii) An affidavit under oath, if required, stating that so far as the Contractor has knowledge or information, there are no claims or claims of lien which have been or will be filed by any Subcontractor, Supplier or other party for labor or material for which a claim or claim of lien could be filed.
- (iii) A release, if required, of all claims and claims of lien made by any Subcontractor, Supplier or other party against the Owner or unpaid Contract funds held by the Owner arising under or related to the Work on the Project; provided, however, that if any Subcontractor, Supplier or others refuse to furnish a release of such claims or claims of lien, the Contractor may furnish a bond executed by Contractor and its Surety to the Owner to provide an unconditional obligation to defend, indemnify and hold harmless the Owner against any loss, cost or expense, including attorney's fees, arising out of or as a result of such claims, or claims of lien, in which event Owner may make Final Payment notwithstanding such claims or claims of lien. If Contractor and Surety fail to fulfill their obligations to Owner under the bond, the Owner shall be entitled to recover damages as a result of such failure, including all costs and reasonable attorney's fees incurred to recover such damages.

(e) Effect of Final Payment.

- (i) The making of Final Payment shall constitute a waiver of Claims by the Owner except those arising from:
 - (1) Liens, claims, security interests or encumbrances arising out of the Contract and unsettled;
 - (2) Failure of the Work to comply with the requirements of the Contract Documents;
 - (3) Terms of warranties or indemnities required by the Contract Documents, or
 - (4) Blatant defects.
- (ii) Acceptance of Final Payment by the Contractor shall constitute a waiver of claims by Contractor except those previously made in writing, identified by Contractor as unsettled at the time of final Application for Payment, and specifically excepted from the release provided for in Paragraph (d) (1), above.

3.35 CONTRACTOR'S WARRANTY.

(a) General Warranty. The Contractor warrants to the Owner that all materials and equipment furnished under the Contract will be of good quality and new, except such materials as may be expressly provided or allowed in the Contract Documents to be otherwise, and that none of the Work will be Defective Work as defined in Section 3.1.

(b) **One-Year Warranty.**

- (i) If, within one year after the date of Completion of the Work or each designated portion of the Work (or otherwise as agreed upon in a mutually-executed Certificate of Completion), any of the Work is found to be Defective Work, the Contractor shall promptly upon receipt of written notice from the Owner and without expense to the Owner, replace or correct the Defective Work to conform to the requirements of the Contract Documents, and repair all damage to the site, the building and its contents which is the result of Defective Work or its replacement or correction.
- (ii) The one-year warranty for punch list items shall begin on the Date of Completion if they are completed or corrected within the time period allowed in the Certificate of Substantial Completion in which they are recorded. The one-year warranty for punch list items that are not completed or corrected within the time period allowed in the Certificate of Substantial Completion, and other Work performed after Substantial Completion, shall begin on the date of Final Acceptance of the Work. The Contractor's correction of Work pursuant to this warranty does not extend the period of the warranty. The Contractor's one-year warranty does not apply to defects or damages due to improper or insufficient maintenance, improper operation, or wear and tear during normal usage.
- (iii) Upon recognizing a condition of Defective Work, the Owner shall promptly notify the Contractor of the condition. If the condition is causing damage to the building, its contents, equipment, or site, the Owner shall take reasonable actions to mitigate the damage or its continuation, if practical. If the Contractor fails to proceed promptly to comply with the terms of the warranty, or to provide the Owner with satisfactory written verification that positive action is in process, the Owner may have the Defective Work replaced or corrected and the Contractor and the Contractor's Surety shall be liable for all expense incurred.
- (iii) **Year-End Inspection(s):** An inspection of the Work, or each separately completed portion thereof, is required near the end of the Contractor's one-year warranty period(s). The subsequent delivery of the report of a Year-end Inspection will serve as confirmation that the Contractor was notified of Defective Work found within the warranty period.
- (v) The Contractor's warranty of one year is in addition to, and not a limitation of, any other remedy stated herein or available to the Owner under applicable law.

3.36 INDEMNIFICATION AGREEMENT. To the fullest extent permitted by law, the Contractor shall defend, indemnify, and hold harmless the Owner, Owner's consultants, and their agents, employees, and consultants (hereinafter collectively referred to as the

“Indemnitees”) from and against all claims, damages, losses and expenses, including but not limited to attorneys’ fees, arising out of, related to, or resulting from performance of the Work, provided that such claim, damage, loss or expense is attributable to bodily injury, sickness, disease or death, or to injury to or destruction of tangible property, including loss of use resulting there from, and is caused in whole or in part by negligent acts or omissions of the Contractor, a Subcontractor, anyone directly or indirectly employed by them, or anyone for whose acts they may be liable, regardless of whether such claim, damage, loss or expense is caused in part, or is alleged but not legally established to have been caused in whole or in part by the negligence or other fault of a party indemnified hereunder.

(a) This indemnification shall extend to all claims, damages, losses and expenses for injury or damage to adjacent or neighboring property, or persons injured thereon, that arise out of, relate to, or result from performance of the Work.

(b) This indemnification does not apply to the extent of the sole negligence of the Indemnitees.

3.37 CONTRACTOR’S AND SUBCONTRACTORS’ INSURANCE.

(a) **General.**

(i) **Responsibility.** The Contractor shall be responsible to the Owner from the time of the signing of the Construction Contract or from the beginning of the first work, whichever shall be earlier, for all injury or damage of any kind resulting from any negligent act or omission or breach, failure or other default regarding the work by the Contractor, a Subcontractor, anyone directly or indirectly employed by them or anyone for whose acts they may be liable, regardless of who may be the owner of the property.

(ii) **Insurance Providers.** Each of the insurance coverage’s required below shall be issued by an insurer licensed by the Insurance Commissioner to transact the business of insurance in the State of Alabama for the applicable line of insurance, and such insurer (or, for qualified self-insured or group self-insured, a specific excess insurer providing statutory limits) must have a Best Policyholders Rating of “A-” or better and a financial size rating of Class V or larger.

(iii) **Notification Endorsement.** Each policy shall be endorsed to provide that the insurance company agrees that the policy shall not be canceled, changed, allowed to lapse or allowed to expire for any reason until thirty days after the Owner has received written notice by certified mail as evidenced by return receipt or until such time as other insurance coverage providing protection equal to protection called for in the Contract Documents shall have been received, accepted and acknowledged by the Owner. Such notice shall be valid only as to the Project as shall have been designated by Project Name and Number in said notice.

(iv) **Insurance Certificates.** The Contractor shall procure the insurance coverage’s identified below, or as otherwise required in the Contract Documents, at the Contractor’s own expense, and to

evidence that such insurance coverage's are in effect, the Contractor shall furnish the Owner an insurance certificate(s) acceptable to the Owner and listing the Owner as the certificate holder. The insurance certificate(s) must be delivered to the Owner with the Construction Contract and Bonds for final approval and execution of the Construction Contract. The insurance certificate must provide the following:

- (1) Name and address of authorized agent of the insurance company
 - (2) Name and address of insured
 - (3) Name of insurance company or companies
 - (4) Description of policies
 - (5) Policy Number(s)
 - (6) Policy Period(s)
 - (7) Limits of liability
 - (8) Name and address of Owner as certificate holder
 - (9) Project Name and Number, if any
 - (10) Signature of authorized agent of the insurance company
 - (11) Telephone number of authorized agent of the insurance company
 - (12) Mandatory thirty day notice of cancellation / non-renewal / change
- (v) **Maximum Deductible.** Self-insured retention, except for qualified self-insurers or group self-insurers, in any policy shall not exceed \$25,000.00.

(b) **Insurance Coverage's.** Unless otherwise provided in the Contract Documents, the Contractor shall purchase the types of insurance coverage's with liability limits not less than as follows:

- (i) **Workers' Compensation and Employer's Liability Insurance.**
 - (1) Workers' Compensation coverage shall be provided in accordance with the statutory coverage required in Alabama. A group insurer must submit a certificate of authority from the Alabama Department of Industrial Relations approving the group insurance plan. A self-insurer must submit a certificate from the Alabama Department of Industrial Relations stating the Contractor qualifies to pay its own workers' compensation claims.
 - (2) Employer's Liability Insurance limits shall be at least:
Bodily Injury by Accident - \$1,000,000 each accident
Bodily Injury by Disease - \$1,000,000 each employee
- (ii) **Commercial General Liability Insurance.**
 - (1) Commercial General Liability Insurance, written on an ISO Occurrence Form (current edition as of the date of Advertisement for Bids) or equivalent, shall include, but need not be limited to, coverage for bodily injury and

property damage arising from premises and operations liability, products and completed operations liability, blasting and explosion, collapse of structures, underground damage, personal injury liability and contractual liability. The Commercial General Liability Insurance shall provide at minimum the following limits:

	<u>Coverage</u>	<u>Limit</u>
1.	General Aggregate	\$1,000,000 per Project
2.	Products, Completed Operations Aggregate	\$1,000,000 per Project
3.	Personal and Advertising Injury	\$1,000,000 per Occurrence
4.	Each Occurrence	\$1,000,000

(2) Additional Requirements for Commercial General Liability Insurance:

- a. The policy shall name the Owner, and their agents, consultants and employees as additional insured, state that this coverage shall be primary insurance for the additional insured; and contain no exclusions of the additional insured relative to job accidents.
- b. The policy must include separate per project aggregate limits.

(iii) **Commercial Business Automobile Liability Insurance.**

- (1) Commercial Business Automobile Liability Insurance which shall include coverage for bodily injury and property damage arising from the operation of any owned, non-owned or hired automobile. The Commercial Business Automobile Liability Insurance Policy shall provide not less than \$1,000,000 Combined Single Limits for each occurrence.
- (2) The policy shall name the Owner, and their agents, consultants, and employees as additional insureds.

(iv) **Commercial Umbrella Liability Insurance.**

- (1) Commercial Umbrella Liability Insurance to provide excess coverage above the Commercial General Liability, Commercial Business Automobile Liability and the Workers' Compensation and Employer's Liability to satisfy the minimum limits set forth herein.
- (2) Minimum Combined Primary Commercial General Liability and Commercial/Excess Umbrella Limits of:
\$ 2,000,000 per Occurrence
\$ 2,000,000 Aggregate
- (3) Additional Requirements for Commercial Umbrella Liability Insurance:

- a. The policy shall name the Owner, and their agents, consultants, and employees as additional insureds.
- b. The policy must be on an “occurrence” basis.

(v) **Builder’s Risk Insurance.**

- (1) The Builder’s Risk Policy shall be made payable to the Owner and Contractor, as their interests may appear. The policy amount shall be equal to 100% of the Contract Sum, written on a Causes of Loss - Special Form (current edition as of the date of Advertisement for Bids), or its equivalent. All deductibles shall be the sole responsibility of the Contractor.
- (2) The policy shall be endorsed as follows: “The following may occur without diminishing, changing, altering or otherwise affecting the coverage and protection afforded the insured under this policy:
 - a. Furniture and equipment may be delivered to the insured premises and installed in place ready for use; or
 - b. Partial or complete occupancy by Owner; or
 - c. Performance of work in connection with construction operations insured by the Owner, by agents or lessees or other contractors of the Owner, or by contractors of the lessee of the Owner.”

(c) **Subcontractors’ Insurance.**

- (i) **Workers’ Compensation and Employer’s Liability Insurance.** The Contractor shall require each Subcontractor to obtain and maintain Workers’ Compensation and Employer’s Liability Insurance coverages as described in preceding Paragraph (b), or to be covered by the Contractor’s Workers’ Compensation and Employer’s Liability Insurance while performing Work under the Contract.
- (ii) **Liability Insurance.** The Contractor shall require each Subcontractor to obtain and maintain adequate General Liability, Automobile Liability, and Umbrella Liability Insurance coverages similar to those described in preceding Paragraph (b). Such coverage shall be in effect at all times that a Subcontractor is performing Work under the Contract.
- (iii) **Enforcement Responsibility.** The Contractor shall have responsibility to enforce its Subcontractors’ compliance with these or similar insurance requirements; however, the Contractor shall, upon request, provide the Owner acceptable evidence of insurance for any Subcontractor.

(d) **Termination of Obligation to Insure.** Unless otherwise expressly provided in the Contract Documents, the obligation to insure as provided herein shall continue as follows:

- (i) Builder's Risk Insurance. The obligation to insure under Subparagraph b(v) shall remain in effect until the Date of Substantial Completion as shall be established in the Certificate of Substantial Completion. In the event that multiple Certificates of Substantial Completion covering designated portions of the Work are issued, Builder's Risk coverage shall remain in effect until the Date of Substantial Completion as shall be established in the last issued Certificate of Substantial Completion. However, in the case that the Work involves separate buildings, Builder's Risk coverage of each separate building may terminate on the Date of Substantial Completion as established in the Certificate of Substantial Completion issued for each building.
- (ii) Products and Completed Operations. The obligation to carry Products and Completed Operations coverage specified under Subparagraph b(ii) shall remain in effect for two years after the Date(s) of Substantial Completion.
- (iii) All other Insurance. The obligation to carry other insurance coverage's specified under Paragraph (b) shall remain in effect after the Date(s) of Substantial Completion until such time as all Work required by the Contract Documents is completed. Equal or similar insurance coverages shall remain in effect if, after completion of the Work, the Contractor, a Subcontractor, anyone directly or indirectly employed by them or anyone for whose acts they may be liable, returns to the Project to perform warranty or maintenance work pursuant to the terms of the Contract Documents.

(e) **Waivers of Subrogation.** The Owner and Contractor waive all rights against (1) each other and any of their subcontractors, sub-subcontractors, agents and employees, each of the other, and (2) the separate contractors performing construction or operations related to the Project, if any, and any of their subcontractors, sub-subcontractors, agents and employees, for damages caused by fire or other causes of loss to the extent covered by builder's risk insurance or other property insurance applicable to the Work or to other property located within or adjacent to the Project, except such rights as they may have to proceeds of such insurance held by the Owner or Contractor as fiduciary. The Owner or Contractor, as appropriate, shall require of the separate contractors, if any, and the subcontractor, sub-subcontractors, suppliers, agents and employees of any of them, by appropriate agreements, written where legally required for validity, similar waivers each in favor of other parties enumerated herein. The Policies shall provide such waivers of subrogation by endorsement or otherwise. A waiver of subrogation shall be effective as to the person or entity even though that person or entity would otherwise have a duty of indemnification, contractual or otherwise, did not pay the insurance premium directly or indirectly, and whether or not the person or entity had an insurable interest in the property damaged. The waivers provided for in this paragraph shall survive final acceptance and continue to apply to insured losses to the Work or other property on or adjacent to the Project.

3.38 PERFORMANCE AND PAYMENT BONDS.

(a) **General.** Upon signing and returning the Construction Contract to the Owner for final approval and execution, the Contractor shall, at the Contractor's expense, furnish to the Owner a Performance Bond and a Payment Bond, each in a penal sum equal to 100% of the Contract Sum. Each bond shall be on the form contained in the Bid Package, shall be executed by a surety company (Surety) acceptable to the Owner and duly authorized and qualified to make such bonds in the State of Alabama in the required amounts, shall be countersigned by an authorized, Alabama resident agent of the Surety who is qualified to execute such instruments, and shall have attached thereto a power of attorney of the signing official.

The provisions of this Section are not applicable to this Contract if the Contract Sum is less than \$50,000, unless bonds are required for this Contract in the Supplemental General Conditions.

(b) **Performance Bond.** Through the Performance Bond, the Surety's obligation to the Owner shall be to assure the prompt and faithful performance of the Contract and Contract Change Orders. The Penal Sum shall remain equal to the Contract Sum as the Contract Sum is adjusted by Contract Change Orders. In case of default on the part of the Contractor, the Surety shall take charge of and complete the Work in accordance with the terms of the Performance Bond. Any reasonable expenses incurred by the Owner as a result of default on the part of the Contractor, including architectural, engineering, administrative, and legal services, shall be recoverable under the Performance Bond.

(c) **Payment Bond.** Through the Payment Bond the Surety's obligation to the Owner shall be to guarantee that the Contractor and its Subcontractors shall promptly make payment to all persons supplying labor, materials, or supplies for, or in, the prosecution of the Work, including the payment of reasonable attorney's fees incurred by successful claimants or plaintiffs in civil actions on the Bond. Any person or entity indicating that they have a claim of nonpayment under the Bond shall, upon written request, be promptly furnished a certified copy of the Bond and Construction Contract by the Contractor, or Owner, whomever is recipient of the request.

(d) **Change Orders.** The Penal Sum shall remain equal to the Contract Sum as the Contract Sum is adjusted by Contract Change Orders. All Contract Change Orders involving an increase in the Contract Sum will require consent of Surety by endorsement of the Contract Change Order form. The Surety waives notification of any Contract Change Orders involving only extension of the Contract Time.

(e) **Expiration.** The obligations of the Contractor's performance bond surety shall be coextensive with the contractor's performance obligations under the Contract Documents; provided, however, that the surety's obligation shall expire at the end of the one-year warranty period(s) of Section 3.35.

3.39 ASSIGNMENT. The Contractor shall not assign the Contract or sublet it as a whole nor assign any moneys due or to become due to the Contractor thereunder without the previous written consent of the Owner (and of the Surety, in the case of a bonded Construction Contract). As prescribed by the Public Works Law, the Contract shall in no event be assigned to an unsuccessful bidder for the Contract whose bid was rejected because the bidder was not a responsible or responsive bidder.

3.40 CONSTRUCTION BY OWNER OR SEPARATE CONTRACTORS.

(a) Owner's Reservation of Right.

- (i) The Owner reserves the right to self-perform, or to award separate contracts for, other portions of the Project and other Project related construction and operations on the site. The contractual conditions of such separate contracts shall be substantially similar to those of this Contract, including insurance requirements and the provisions of this section. If the Contractor considers such actions to involve delay or additional cost under this Contract, notifications and assertion of claims shall be as provided in Section 3.20 and Section 3.23.
- (ii) When separate contracts are awarded, the term "Contractor" in the separate Contract Documents shall mean the Contractor who executes the respective Construction Contract.

(b) Coordination. Unless otherwise provided in the Contract Documents, the Owner shall be responsible for coordinating the activities of the Owner's forces and separate contractors with the Work of the Contractor. The Contractor shall cooperate with the Owner and separate contractors, shall participate in reviewing and comparing their construction schedules relative to that of the Contractor when directed to do so, and shall make and adhere to any revisions to the construction schedule resulting from a joint review and mutual agreement.

(c) Conditions Applicable to Work Performed by Owner. Unless otherwise provided in the Contract Documents, when the Owner self-performs construction or operations related to the Project, the Owner shall be subject to the same obligations to Contractor as Contractor would have to a separate contractor under the provision of this Section 3.40.

(d) Mutual Responsibility.

- (i) The Contractor shall reasonably accommodate the required introduction and storage of materials and equipment and performance of activities by the Owner and separate contractors and shall connect and coordinate the Contractor's Work with theirs as required by the Contract Documents.
- (ii) By proceeding with an element or portion of the Work that is applied to or performed on construction by the Owner or a separate contractor, or which relies upon their operations, the Contractor accepts the condition of such construction or operations as being suitable for the Contractor's Work, except for conditions that are not reasonably discoverable by the Contractor. If the Contractor discovers any condition in such construction or operations that is not suitable for the proper performance of the Work, the Contractor shall not proceed, but shall instead promptly notify the Owner in writing of the condition discovered.
- (iii) The Contractor shall reimburse the Owner for any costs incurred by a separate contractor and payable by the Owner because of acts or omissions of the Contractor. Likewise, the Owner shall be responsible to the Contractor for any costs incurred by the Contractor because of the acts or omissions of a separate contractor.

- (iv) The Contractor shall not cut or otherwise alter construction by the Owner or a separate contractor without the written consent of the Owner and separate contractor; such consent shall not be unreasonably withheld. Likewise, the Contractor shall not unreasonably withhold its consent allowing the Owner or a separate contractor to cut or otherwise alter the Work.
- (v) The Contractor shall promptly remedy any damage caused by the Contractor to the construction or property of the Owner or separate contractors.

3.41 SUBCONTRACTS.

- (a) **Award of Subcontracts and Other Contracts for Portion of the Work.**
 - (i) Unless otherwise provided in the Contract Documents, when delivering the executed Construction Contract, bonds, and evidence of insurance to the Owner the Contractor shall also submit a listing of Subcontractors proposed for each principal portion of the Work and fabricators or suppliers proposed for furnishing materials or equipment fabricated to the design of the Contract Documents. This listing shall be in addition to any naming of Subcontractors, fabricators, or suppliers that may have been required in the bid process. The Owner will promptly reply to the Contractor in writing stating whether or not the Owner, after due investigation, has reasonable objection to any Subcontractor, fabricator, or supplier proposed by the Contractor. The issuance of the Notice to Proceed in the absence of such objection by the Owner shall constitute notice that no reasonable objection to them is made.
 - (ii) The Contractor shall not contract with a proposed Subcontractor, fabricator, or supplier to whom the Owner has made reasonable and timely objection. Except in accordance with prequalification procedures as may be contained in the Contract Documents, through specified qualifications, or on the grounds of reasonable objection, the Owner may not restrict the Contractor's selection of Subcontractors, fabricators, or suppliers.
 - (iii) Upon the Owner's reasonable objection to a proposed Subcontractor, fabricator, or supplier, the Contractor shall promptly propose another to whom the Owner has no reasonable objection. If the proposed Subcontractor, fabricator, or supplier to whom the Owner made reasonable objection was reasonably capable of performing the Work, the Contract Sum and Contract Time shall be equitably adjusted by Contract Change Order for any resulting difference if the Contractor has acted promptly and responsively in this procedure.
 - (iv) The Contractor shall not change previously selected Subcontractors, fabricators, or suppliers without notifying the Owner in writing of proposed substitute Subcontractors,

fabricators, or suppliers. If the Owner does not make a reasonable objection to a proposed substitute within three working days, the substitute shall be deemed approved.

(b) Subcontractor Relations.

- (i) The Contractor agrees to bind every Subcontractor and material supplier (and require every Subcontractor to so bind its subcontractors and material suppliers) to all the provisions of the Contract Documents as they apply to the Subcontractor's and material supplier's portion of the Work.
- (ii) Nothing contained in the Contract Documents shall be construed as creating any contractual relationship between any Subcontractor and the Owner, nor to create a duty of the Owner to resolve disputes between or among the Contractor or its Subcontractors and suppliers or any other duty to such Subcontractors or suppliers.

3.42 PERMITS, LAWS AND REGULATIONS.

(a) Permits, Fees and Notices.

- (i) Unless otherwise provided in the Contract Documents, the Contractor shall secure and pay for the building permit and other permits and governmental fees, licenses, and inspections necessary for proper execution and completion of the Work which are customarily secured after award of the Construction Contract and which are in effect on the date of receipt of bids.
- (ii) The Contractor shall comply with and give notices required by all laws, ordinances, rules, regulations, and lawful orders of public authorities applicable to performance of the Work.

(b) Taxes. Unless stated otherwise in the Contract Documents, materials incorporated into the Work should be exempt from sales and use tax. The Contractor and its subcontractors shall be responsible for complying with rules and regulations of the Sales, Use, & Business Tax Division of the Alabama Department of Revenue regarding certificates and other qualifications necessary to claim such exemption when making qualifying purchases from vendors. The Contractor shall pay all applicable taxes that are not otherwise exempt and which are imposed as of the date of receipt of bids, including those imposed as of the date of receipt of bids but scheduled to go into effect after that date. Pursuant to Code of Alabama § 40-9-14.1 (1975) and Alabama Administrative Code r. 810-6-3-.77 (2013) Madison County anticipates applying to the Alabama Department of Revenue for a Sales and Use Tax Certificate of Exemption immediately after the contract is fully executed. The Contractor agrees to likewise apply to the Alabama Department of Revenue immediately upon receipt of the fully executed contract and to provide such additional information to the Alabama Department of Revenue as may be necessary to secure the Sales and Use Tax Exemption Certificate for this Project.

(c) Compensation for Taxes if Exemption is Denied. The Contractor shall be compensated for the actual amount of sales and use tax on materials incorporated in the Work if the Sales and Use Tax Certificate of Exemption is not issued by the Alabama Department of Revenue.

(d) **Compensation for Increases.** The Contractor shall be compensated for additional costs incurred because of increases in tax rates imposed after the date of receipt of bids.

3.43 ROYALTIES, PATENTS AND COPYRIGHTS. The Contractor shall pay all royalties and license fees. The Contractor shall defend, indemnify and hold harmless the Owner and their agents, employees, and consultants from and against all claims, damages, losses and expenses, including but not limited to attorney's fees, arising out of, related to, or resulting from all suits or claims for infringement of any patent rights or copyrights arising out of the inclusion of any patented or copyrighted materials, methods, or systems selected by the Contractor and used during the execution of or incorporated into the Work. This indemnification does not apply to any suits or claims of infringement of any patent rights or copyrights arising out of any patented or copyrighted materials, methods, or systems specified in the Contract Documents. However, if the Contractor has information that a specified material, method, or system is or may constitute an infringement of a patent or copyright, the Contractor shall be responsible for any resulting loss unless such information is promptly furnished to the Owner.

3.44 USE OF THE SITE.

(a) The Contractor shall confine its operations at the Project site to areas permitted by the Owner and by law, ordinances, permits and the Contract Documents and shall not unreasonably encumber the site with materials, equipment, employees' vehicles, or debris. The Contractor's operations at the site shall be restricted to the sole purpose of constructing the Work, use of the site as a staging, assembly, or storage area for other business which the Contractor may undertake shall not be permitted.

(b) Unless otherwise provided in the Contract Documents, temporary facilities, such as storage sheds, shops, and offices may be erected on the Project site with the approval of the Owner. Such temporary buildings and/or utilities shall remain the property of the Contractor, and be removed at the Contractor's expense upon completion of the Work, unless the Owner authorizes their abandonment without removal.

3.45 CUTTING AND PATCHING.

(a) The Contractor shall be responsible for all cutting, fitting, or patching that may be required to execute the Work to the results indicated in the Contract Documents or to make its parts fit together properly.

(b) Any cutting, patching, or excavation by the Contractor shall be supervised and performed in a manner that will not endanger persons nor damage or endanger the Work or any fully or partially completed construction of the Owner or separate contractors.

3.46 IN-PROGRESS AND FINAL CLEANUP.

(a) **In-Progress Clean-Up.**

(i) The Contractor shall at all times during the progress of the Work keep the premises and surrounding area free from rubbish, scrap materials and debris resulting from the Work. Trash and combustible materials shall not be allowed to accumulate inside buildings or elsewhere on the premises. At no time shall any

rubbish be thrown from window openings. Burning of trash and debris on site is not permitted.

- (ii) The Contractor shall make provisions to minimize and confine dust and debris resulting from construction activities.

(b) Final Clean-Up. Before Substantial Completion or Final Acceptance is achieved, the Contractor shall have removed from the Owner's property all construction equipment, tools, and machinery; temporary structures and/or utilities including the foundations thereof (except such as the Owner permits in writing to remain); rubbish, debris, and waste materials; and all surplus materials, leaving the site clean and true to line and grade, and the Work in a safe and clean condition, ready for use and operation.

(c) Owner's Right to Clean-Up. If the Contractor fails to comply with these clean-up requirements and then fails to comply with a written directive by the Owner to clean-up the premises within a specified time, the Owner may implement appropriate clean-up measures and the cost thereof shall be deducted from any amounts due or to become due the Contractor.

3.47 LIQUIDATED DAMAGES.

(a) Time is the essence of the Contract. Any delay in the completion of the Work required by the Contract Documents may cause inconvenience to the public and loss and damage to the Owner including but not limited to interest and additional administrative, architectural, inspection and supervision charges. By executing the Construction Contract, the Contractor agrees that the Contract Time is sufficient for the achievement of Substantial Completion.

(b) The Contract Documents may provide in the Construction Contract or elsewhere for a certain dollar amount for which the Contractor and its Surety (if any) will be liable to the Owner as liquidated damages for each calendar day after expiration of the Contract Time that the Contractor fails to achieve Substantial Completion of the Work. If such daily liquidated damages are provided for, Owner and Contractor, and its Surety, agree that such amount is reasonable and agree to be bound thereby.

(c) If a daily liquidated damage amount is not otherwise provided for in the Contract Documents, a time charge equal to six percent interest per annum on the total Contract Sum may be made against the Contractor for the entire period after expiration of the Contract Time that the Contractor fails to achieve Substantial Completion of the Work.

(d) The amount of liquidated damages due under either paragraph b or c above, may be deducted by the Owner from the moneys otherwise due the Contractor in the Final Payment, not as a penalty, but as liquidated damages sustained, or the amount may be recovered from Contractor or its Surety. If part of the Work is substantially completed within the Contract Time and part is not, the stated charge for liquidated damages shall be equitably prorated to that portion of the Work that the Contractor fails to substantially complete within the Contract Time. It is mutually understood and agreed between the parties hereto that such amount is reasonable as liquidated damages.

3.48 USE OF FOREIGN MATERIALS.

(a) In the performance of the Work the Contractor agrees to use materials, supplies, and products manufactured, mined, processed or otherwise produced in the United States or its territories, if same are available at reasonable and competitive prices and are not contrary to any sole source specification implemented under the Public Works Law.

(b) In the performance of the Work the Contractor agrees to use steel produced in the United States if the Contract Documents require the use of steel and do not limit its supply to a sole source pursuant to the Public Works Law. If the Owner decides that the procurement of domestic steel products becomes impractical as a result of national emergency, national strike, or other cause, the Owner shall waive this restriction.

(c) If domestic steel or other domestic materials, supplies, and products are not used in accordance with preceding Paragraphs A and B, the Contract Sum shall be reduced by an amount equal to any savings or benefits realized by the Contractor.

(d) This Article applies only to Public Works projects financed entirely by the State of Alabama or any political subdivision of the state.

4. SPECIAL CONDITIONS

4.1. PERIOD OF PERFORMANCE AND SUBSTANTIAL COMPLETION.

(a) **Period of Performance.** The Contractor shall perform the Work in one hundred eighty (180) calendar days. The period of performance shall begin with the date on the Notice to Proceed. The period of performance includes ten (10) days for Madison County to perform the bacteriological testing after the main is installed, pressure tested and disinfected. Installation of new meter and connection to the customer line cannot begin until successful completion of the bacteriological testing.

(b) **Substantial Completion.** Substantial completion shall be achieved when the services are transferred and the landscaping is complete.

4.2. SOURCE OF PROJECT FUNDING. Local funds, deemed by the Owner to be an amount sufficient to fulfill the Owner's obligations under this Contract, are to be the source of funding for the project.

4.3. COORDINATION WITH MADISON COUNTY WATER DEPARTMENT. In addition to the coordination requirements contained in the General Conditions and Technical Specifications, the Contractor will coordinate daily with the Madison County Water Department Inspector to keep the inspector informed of the status on the project and to coordinate required inspections. The coordination can occur on-site or via telephone call. Ms. Bailee Robinson will be the primary inspector and point of contact.

4.4. CONTRACT ADMINISTERED BY MADISON COUNTY WATER DEPARTMENT

(a) The contract will be administered by the Madison County Water Department. All correspondence, requests for information, application for payment should be sent to the Madison County Water Department in the attention of Ms. Bailee Robinson. The Madison County Water Department is located at 266-B Shields Rd Huntsville, AL 35811.

(b) After the contract is awarded, all correspondence from the Owner will be signed by Ms. Bailee Robinson, Assistant County Engineer. Contract change orders and supplemental agreements shall be signed by Mr. Dale W. Strong, Chairman Madison County Commission.

4.5. NOTIFICATION REQUIREMENTS.

(a) All requirements for written notification and submittals shall be delivered to Ms. Bailee Robinson at Madison County Water Department located at 266-B Shields Rd Huntsville, AL 35811.

(b) All requirements for verbal notification shall be made to Ms. Bailee Robinson telephone (256) 746-2871. In Ms. Robinson's absence, notifications are to be made to Mr. John Buxton at (256) 746-2870. Leaving a message does not meet the requirement of verbal notification.

(c) The owner shall notify the Contractor in writing for changes to personnel, address, or telephone number.

4.6. ENGINEER FOR THE WORK. The plans and specifications for the project were prepared by the Engineering section of the Madison County Water Department. The Engineer of Record is Mr. John Buxton, P.E., Assistant County Engineer. References in the Technical Specifications to Madison County Representative (MCR) include the inspectors designated in Section 4.7 and Mr. Chuck Faulkner. In instances where a Professional Engineer is required, Mr. Buxton or Mr. Faulkner will make the necessary decisions.

4.7. DESIGNATION OF INSPECTORS.

(a) Ms. Bailee Robinson will serve as the primary inspector. A contact number is (256) 746-2871.

(b) Mr. John Buxton and Mr. Stephen Young will serve as alternate inspectors. They can be contacted by calling Madison County Water Department at (256) 746-2888.

(c) Additional Madison County personnel will inspect specific aspects of the Work such as main disinfection. The primary inspector will inform the superintendent of the names of additional task specific inspectors.

(d) The owner will notify the Contractor in writing any changes to the primary and alternate inspectors.

4.8. EMERGENCY CONTACT INFORMATION. The Contractor shall furnish an emergency phone number, other than the day-to-day number, whereby construction related emergencies may be reported during night hours, weekends and holidays, and shall arrange for an adequate local crew to be “on call” each night, weekend and holidays during the project for the purpose of responding to emergency situations.

4.9. OWNER’S REPRESENTATIVE. The Owner’s Representative for this Project shall be: Ms. Bailee Robinson, Assistant County Engineer, Madison County Water Department, and address 266 Shields Rd Huntsville, AL 35811, phone (256)746-2871, email brobinson@madisoncountyal.gov. The Owner’s Representative shall review and approve progress payments in accordance with Section 3.29 (b). The Owner will notify the Contractor if the Owner’s Representative or any associated contact information changes during the Project.

4.10. PRECONSTRUCTION VIDEO. The Contractor shall prepare two (2) copies of a CD, DVD, or other media, showing all areas in order to have a record of the general condition and appearance of all public and private property on which water mains or services are to be located prior to the beginning of construction. The location, direction, and any pertinent information concerning the property shall be included with the media. This may be accomplished using the soundtrack available on the tape of other suitable means. Detailed views of specific items such as headwalls, retaining walls, driveways, streets, sidewalks, ornamental shrubbery and trees, buildings, and other important topographical features shall be provided. A description of location and specific features shall be provided with the detailed views by utilizing the soundtrack or other suitable means. The Contractor shall retain one (1) copy of the media to use as a reference in restoring property and shall deliver a second copy to Madison County prior to the start of construction.

4.11. CONTRACTOR RESPONSIBLE FOR LOCATING UTILITIES. The Contractor will be responsible for locating all underground utilities including but not limited to water mains, electric, telephone, natural gas, cable television, and fiber optic cables. The Contractor is responsible to insure all underground utilities are located by the proper organizations and clearly marked on the ground. Additionally, the Contractor must insure the utility locates are kept current and updated during the Work.

4.12. DAMAGE TO PROPERTY. The Contractor shall pay at his own expense for damage to property resulting from the Work. Refer to Section 3.14 of the “General Conditions of the Contract”

4.13. PRESSURE TESTING, DISINFECTION AND SAMPLING. The Contractor shall flush, pressure test, and disinfect the water main according to the requirements in the Technical Specifications. Madison County will perform the bacteria sampling. This sampling must be coordinated with the Inspector. Samples can be taken on Monday through Thursday before 1 PM. The Contractor must provide 3 work days notice to have a sample taken. The sample results will be provided to the Contractor within two work days of the sample being taken. Madison County will not take or read samples on the weekends. If the sample results are not satisfactory, then the Contractor will be required to disinfect the main and schedule another bacteria sample. This re-disinfection and sampling will continue until the bacterial sample results are satisfactory. Details regarding the testing requirements can be found in Section 5.8 and 5.9 of the Technical Specifications.

4.14. TRAFFIC CONTROL. The Contractor is responsible for controlling traffic at the work sites. The Contractor shall provide and employ traffic control devices to minimize the inconvenience to motorist while maximizing safety according to the Manual on Uniform Traffic Control Devices, for Streets and Highways, Temporary Traffic Control, latest edition. Refer to Section 3.14, Safety and Protection of Persons and Property. The Contractor at no time during the construction shall close roads to vehicle traffic.

4.15. NO STAGING AREA AVAILABLE. The Contractor must make arrangements for the staging of materials and equipment.

4.16. MATERIALS FURNISHED BY MADISON COUNTY. Madison County will furnish the ductile iron pipe, fittings (elbows, bends, solid sleeves, mechanical joint tees, and fire hydrant tees), gate valves, air relief valves, fire hydrants, anchor couplings, gaskets, tee bolts with nuts, Megalug® restrainer glands, valve boxes, joint lubricant, and materials for sample points for installing the water main. Madison County will also furnish the following materials for new meter installation: meters, backflow preventers, tapping saddles, corporation valves, service tubing and curb stops.

Because Madison County is furnishing the materials incorporated into the project, Section 3.42 (b) and (c) under “Permits, Laws and Regulations” are not applicable.

All materials furnished by Madison County Water Department shall be picked up and/or returned at the Madison County Water Department Warehouse, located at 107B Wholesale Ave.

Contractors may pick up and/or return materials between the hours of 9:00 a.m. - 11:00 a.m. and 12:30 p.m. - 2:00 p.m. on Monday, Wednesday, and Friday excluding holidays. The materials will be issued by Mr. Coby Edwards, warehouseman. The Contractor is responsible for removing all old valve boxes, hydrants, meters, backflow preventers and meter boxes. The Contractor shall properly dispose of the valve boxes and meter boxes. The Contractor shall return the old hydrants, meters and backflow preventers to Madison County's warehouse during the hours of operation.

All pipe, valves, fittings, and appurtenances shall be handled so as to prevent any damage, particularly to the lining or coating. All pipe and fittings shall be loaded and unloaded by lifting so as to avoid shock or damage. Under no circumstances shall such materials be dumped, dropped, or otherwise handled in a manner, which may cause damage. The Contractor will inspect material on receipt from the Water Department warehouse. If the Contractor receives any damaged material, the Contractor must notify Mr. Edwards of the damaged materials prior to departing the warehouse. The damaged materials will be exchanged for undamaged materials. After the Contractor has departed the warehouse, the Contractor is responsible for any damage to materials. Madison County will furnish replacement materials for the damaged materials and the cost of replacement materials will be deducted from the Contractor's payment.

4.17. MATERIALS FURNISHED BY CONTRACTOR. The Contractor will provide the following materials: gravel, concrete, concrete blocks, backfill material, encasement pipe for services, additional fittings or pipe needed to reconnect the customer to the new meter, landscaping, erosion control materials and other necessary items not listed as being furnished by Madison County in Section 4.16 in "Special Conditions".

4.18. ROCK REMOVAL. Rock will be encountered during this project. The Contractor is to remove the rock by their method of choice, given the method is approved by the Owner and abides by the contract documents. The Contractor will be paid per linear foot of rock removed for the 12" ductile iron water main installation. The definition of rock, for this project, is a large mass of solid stone, below the earth's surface, larger than 1 cubic yard, that requires special equipment to be removed, including but not limited to, a rock hammer, blasting, etc. Frail rock, such as chert rock and chalk that can be removed with an excavator using rock teeth or other typical construction equipment is not considered rock removal.

4.19. BLASTING.

(a) **Purpose.** This section establishes standards intended to eliminate and reduce unnecessary and excessive airblast overpressures, ground vibrations and dust which are physically harmful and otherwise detrimental to individuals and the community in the enjoyment of life, property and conduct of business. All blasting operations shall be conducted in accordance with prevailing municipal, state or other agency regulations.

All due caution shall be exercised while blasting. If any structure or property is damaged by blasting operations, such structure or property shall be promptly replaced or repaired by the Contractor at its own expense. Without limiting the force and effect of any other provision of these contract documents and to the fullest extent possible, the Contractor shall indemnify and hold harmless the Owner and the Owner's consultants, agent, and employees from and against all

claims, liability, damages, losses, costs and expenses of every kind or type, including but not limited to attorneys' fees arising or resulting from performance of the work, specifically including the use of any explosives for the purpose of facilitating the work. This obligation shall extend to any claim, loss, damage, liability, cost or expense attributable to bodily injury, sickness, disease, death or to injury to or destruction of real or tangible property. Such obligation shall not be construed to negate, abridge or reduce other rights or obligations of indemnity which would otherwise exist.

(b) Certified Blaster. All blasting shall be performed by a certified blaster by the City of Huntsville. A copy of the certification shall be included in the blasting plan.

(c) Independent Instrumentation. The Contractor shall hire an independent firm to perform the required airblast and ground vibrations measurements.

(d) Blasting Plan & Pre-Blast Survey. A written blasting plan and survey of existing structures and utilities shall be submitted to Madison County two weeks prior to any planned blasting operation. The plan and survey shall be reviewed for compliance with the requirements for blasting. The Contractor must receive approval of the plan prior to blasting. Approval of the blasting plan by Madison County does not relieve the Contractor of any liability resulting from the blasting operations.

- (i) The blasting plan will include the following items as a minimum:
 - (1) Name, address, and contact information of the person preparing the blasting plan.
 - (2) Name of the blaster in charge of blasting operations. A copy of the blaster's certificate shall be attached to the plan.
 - (3) Planned blasting schedule.
 - (4) Distance to nearest structure
 - (5) Type of cover to be used.
 - (6) Seismographic monitor information including: company responsible for monitoring, contact name and telephone, seismograph make and model, seismic and acoustic frequency range and response in hertz, date of most recent calibration, and seismograph location.
- (ii) A survey of all structures and utilities within 500 feet of any proposed blasting shall be conducted prior to blasting operations. The survey will note the existing conditions of structures and utilities. Particular emphasis shall be given to observing and recording any existing cracks or other damage to structures.

(e) Blasting Restrictions.

- (i) When blasting operations are performed within 2,000 feet of any structure, railway or highway, before detonation, the blast shall be covered with a minimum of three feet of clean fill dirt and/or a mat to prevent fragments being thrown.
- (ii) Blasting detonations are allowed only during daylight hours, but no earlier than 7:00 a.m. Blasting is prohibited on Sunday.
- (iii) A certified blaster and at least one other witness shall be present during. Blasting shall be performed under the most skilled supervision.

(f) **Vibration & Airblast Overpressure Levels.** The allowable ground vibration and airblast overpressure levels resulting from the detonation of explosives are as follows:

- (i) For ground vibration, levels not to be exceeded at any time are 0.50 inch per second peak particle velocity for frequencies below 40 Hz and 2.00 inches per second for frequencies equal to and greater than 40 Hz; except that if the measured ground vibration level continuously exceeds 0.50 inch per second particle velocity after a period of one second following the maximum particle velocity, the charge weight per delay shall be reduced so that the particle velocity does not exceed 0.50 inch per second.
- (ii) For airblast overpressure, levels not to be exceeded at any time are 129 peak dB_L (linear) – 0.1 Hz high-pass system; 128 peak dB_L (linear) – two Hz high-pass system; and 124 peak dB_L (linear) – five or six Hz high-pass system.

The instrumentation shall be located in the right-of-way at the intersection of the right-of-way and a line connecting the centroid of each blast to the nearest structure. The location of the instrument shall be identified in the blasting plan and approved by Madison County.

(g) **Instrumentation.**

- (i) A three-component direct reading velocity instrument with a frequency response of five Hz or below to 200 Hz and adhering to the design criteria for portable seismographs as outlined in U.S. Department of Interior, Bureau of Mines report RI 8506, "Measurement of Blast-Induced Ground Vibrations and Seismograph Calibration," shall be used for determining compliance with the ground vibration limits specified in section 12-71. The minimum frequency ranges for ground vibration instrumentation are two to 150 Hz for quarry blasting and five to 200 Hz for construction and excavation blasting. The maximum allowable peak particle velocity shall apply to each of the three components.
- (ii) An airblast channel having a frequency range of 0.1 to 200 Hz, two to 200 Hz, or five or six Hz to 200 Hz on a blasting seismograph shall be used for determining compliance with the airblast overpressure levels specified in section 12-71. The instrumentation shall adhere to the design criteria and operational guidelines as outlined in U.S. Department of Interior, Bureau of Mines report RI 8508, "Airblast Instrumentation and Measurement Techniques for Surface Mine Blasting."
- (iii) Instruments shall be operated in accordance with the instrument manufacturer's instructions. Instrument measurements shall be considered valid only when ambient levels are less than 0.1 inch per second and ten dB_L lower than the levels of the explosive blast being measured. Therefore, all instruments shall be set to trigger

no higher than 0.3 inch per second and 118 dB_L on two Hz high-pass systems for monitoring purposes.

(h) Records. Persons responsible for blasting operations shall maintain a record of each blast. The blasting records shall be provided to the Owner after each blast. All records shall contain the following minimum data:

- (i) Name of person responsible for the blasting operation.
- (ii) Location, date and time of blast.
- (iii) Name of blaster in charge.
- (iv) Type of material blasted.
- (v) Number of holes, burden and spacing.
- (vi) Diameter and depth of holes.
- (vii) Types of explosives used.
- (viii) Amount of explosives used.
- (ix) Maximum amount of explosives per delay period of 8 milliseconds or greater.
- (x) Maximum number of holes per delay period of 8 milliseconds or greater.
- (xi) Method of firing and type of circuit.
- (xii) Weather conditions (including such factors as wind directions, ect.)
- (xiii) Height or length of stemming.
- (xiv) If mats or other protection were used.
- (xv) Type of detonators used and delay periods used.
- (xvi) Seismograph and airblast readings when measured.

4.20 FINAL COMPLETION AND ACCEPTANCE. The contractor shall inform the MCR when the project is complete. The MCR shall inspect the work. If completed in accordance with this specification, Madison County shall issue the Contractor a letter of final acceptance which shall mark the beginning of the contractor's one year warranty period. If the work is found to be incomplete or not completed in accordance with specifications, Madison County shall notify the Contractor of the reasons for non-acceptance.

(a) Minimum Requirements for Final Acceptance:

- (i) Pass pressure test
- (ii) Bacteriological samples pass ADEM and ADPH requirements
- (iii) All valves and valve boxes to grade and operable
- (iv) All fire hydrants to grade, operable, and properly located at the intersection of property lines and right-of-way or easement lines (unless other location specified) with pumper nozzles facing the street
- (v) Acceptance of the as-built drawing
- (vi) All meters are returned to service on new main
- (vii) Completion of landscaping and repairs to driveways and pavement
- (viii) All temporary taps and/or injection taps and blow-offs removed.

4.21 BUILDER'S RISK INSURANCE NOT REQUIRED. Builder's Risk Insurance as described in Section 3.37 (b) (v) is not required for this project.

5. TECHNICAL SPECIFICATIONS

5.1 EROSION/SEDIMENT CONTROL AND STORMWATER MANAGEMENT. Coverage under General NPDES Permit No. ALR100000 from the Alabama Department of Environmental Management (ADEM) is not required for this project. However, it shall be the responsibility of the Contractor to implement/maintain effective erosion and sediment controls according to ADEM's guidelines.

The Contractor must consult the project drawing for the placement of any sediment and erosion control Best Management Practices (BMPs). All controls must be constructed and stabilized prior to disturbance.

All BMPs shall be conducted in accordance with specifications contained in the "Alabama Handbook for Erosion Control, Sediment Control and Stormwater Management on Construction Sites and Urban Areas", latest edition.

Regular site and receiving water(s) inspections must be conducted to ensure the BMPs are properly designed, implemented, maintained and, if necessary, repaired. The Contractor is responsible for daily observations. Any poorly functioning controls, non-compliant discharges, or other deficiencies observed during inspections shall be corrected as soon as possible, but not to exceed five (5) days of the inspection unless prevented by unsafe weather conditions.

Temporary vegetative cover must be implemented on areas anticipating no active disturbance for longer than thirteen (13) days, and permanent re-vegetation or cover on all disturbed areas shall be applied when disturbance is complete. See Section 5.2 (f) below for specifics.

5.2 SURFACE PREPARATION AND RESTORATION.

(a) Clearing and Grubbing. Where clearing or partial clearing of the right-of-way or easements is necessary, such work shall be completed prior to trench excavation. Projecting materials, such as trees, logs, brush, hedges, etc., shall be cut as near to the surface of the ground as possible, and all stumps and roots shall be grubbed out unless specifically stated otherwise. All materials so cleared and grubbed shall be removed from the site or piled for disposal. In no case shall excavated materials be allowed to cover brush or trees prior to disposal.

On public property, existing trees or limbs over 2 inches in diameter shall not be cut unless they are within 4 feet of pipe centerline or specific permission is received from the Madison County Representative (MCR). On private easements or in lawns, no trees or brush shall be cleared or cut without prior approval of the MCR. The Contractor shall be required to remove trees, shrubs, or plants on private property intact, to ball the roots, keep watered as required, and replant in their original location upon completion of pipe laying operations, unless written permission is otherwise obtained from the MCR or unless otherwise specified. The Contractor shall replace, at his own expense, any tree, shrub, or plant damaged as a result of his operations or dies within 6 months of the time it was disturbed or damaged.

Where grubbing is not specifically required, trees, stumps and brush shall be cut to a height of no more than 6 inches above the ground.

The Contractor shall bear all costs of disposing of all cleared and grubbed materials. Unless otherwise specified, all merchantable timber cut from the area designated to be cleared shall become the property of the Contractor.

In no case shall any materials from clearing and grubbing operations be left on the project, be pushed onto abutting private properties, or be buried in embankments or trenches on the project.

(b) Drainage Structures and Pipe Culverts. Existing pipe culverts in conflict with the proposed construction shall be unearthed, carefully disjointed, and stockpiled adjacent to the right-of-way. The pipes shall be cleaned and replaced immediately after new construction is clear so as to cause no serious inconveniences to the property owners and to allow access to their property as quickly as possible. Any culvert pipe in unsuitable condition, for any reason, shall be replaced with suitable pipe at the Contractor's expense. All culverts shall be re-laid to proper grade on a firm bedding of gravel base, 6 inches thick, and mechanically tamped to a density such that settlement will not occur. Where existing rubble or concrete headwalls are cut, damaged or removed, they shall be replaced in an equal or better condition, as determined by the MCR.

(c) Fences. All fences in conflict with the proposed construction shall be removed in a neat and workmanlike manner and then replaced immediately following construction operations. Where materials removed are not suitable for reuse, they shall be replaced with new material of equal or better quality and construction, at the Contractor's expense. All fences shall be rebuilt to line, with posts well set, wires fastened with new staples or ties, and well stretched. All corner and end posts shall be well braced and set a minimum of 30 inches in the ground.

Temporary fences may be required. These shall be the responsibility of the Contractor, who shall also coordinate removal of fences with all property owners. In no case shall fences remain down overnight without express written authorization from the MCR.

(d) Poles, Signs, Guy Wires and Other Utilities. All utility poles, guy wires, sign posts and similar private obstructions, which are indicated on the plans or existing on the ground, shall be removed and replaced by the Contractor at his own expense. In the event street sign posts or signs are damaged or destroyed by the Contractor's operations, they may be replaced by Madison County at the Contractor's expense.

When it is necessary to remove or adjust any utilities, representatives of the utilities involved shall be notified to decide the method and nature of work to be done. The Contractor shall make satisfactory arrangements with other utilities for the required removal or adjustments at the Contractor's expense, unless otherwise specified.

Any and all underground utilities or other structures damaged by the Contractor during the prosecution of the Work shall be repaired or replaced to their original condition by the Contractor at no expense to the Owner.

(e) **Plants and Trees.** Plants and trees shall not be removed unless directed by the MCR. When plants and/or trees are to be removed and replaced, the following steps shall be taken:

- (i) Remove all trees, shrubs or plants, which interfere with construction, intact with root system and protect from drying during construction period.
- (ii) Replace plants to original location as soon as possible, taking care to insure the hole is large enough and no damage is done to root system.
- (iii) Fill hole with good topsoil, tamp lightly and firmly into place, and water plant.

Contractor shall replace, with like kind and size, any plant, tree, or shrub which is disturbed by construction and dies within the warranty period, at no cost to Owner.

(f) **Seeding, Sodding, and Mulching.** All areas disturbed by the construction shall be seeded and mulched in a timely manner. Following backfill, the areas to be seeded shall be brought to the designated grade with not less than the original depth of select topsoil, with due consideration being given to shrinkage and settlement. Care should be taken to insure that all areas which have been disturbed during construction will properly drain. The topsoil shall be free from rocks, roots, or other debris.

Areas to be seeded shall be tilled and fertilized at a minimum rate of 400 pounds of fertilizer per acre; then seeded under favorable weather conditions, during normal and acceptable planting seasons. Seeding rate shall be as recommended for the type of seed mixture to be applied, which shall be equivalent to existing conditions or as approved by the MCR. If the construction is completed during winter months, a temporary seeding of winter rye grass at a minimum rate of 120 pounds per acre shall be undertaken to prevent erosion until spring.

Where slope of ground is flat or gentle slope, a uniform cover of straw mulch shall be spread over the seeded area within a day or two after seeding. All areas with steep slopes shall have protective netting installed or shall be sodded, with the Contractor being responsible for furnishing whatever means necessary to hold the sod in place.

Sodded areas that are disturbed shall be replaced in like kind. Contractor shall sod all yards on the west side of the road disturbed by main installation.

The Contractor shall be responsible for maintaining of seeded areas until final acceptance and for providing a satisfactory stand of grass, to be defined as having no bare spots larger than 3 square feet and no more than 10% of total area with bare spots larger than 1 square foot.

Madison County will furnish water, at no charge, from a fire hydrant along the Project to the Contractor for establishing grassed areas, but it shall be the responsibility of the Contractor to provide whatever means necessary for distributing the water throughout the project.

(g) **Removing and Replacing Pavement.** Remove existing pavement as necessary for installing the pipe line and appurtenances.

- (i) **Marking:** Before removing any pavement, mark the pavement neatly paralleling pipe lines and existing street lines. Space the

marks the width of the trench. Items (v) and (vi) below identify special requirements for driveways.

- (ii) **Breaking or Cutting:** Break asphalt pavement along the marks using jack hammers or other suitable tools. Break concrete pavement along the marks using of jack hammers or by scoring with a rotary saw and breaking below the score with the use of jack hammers or other suitable tools.
- (iii) **Machine Pulling:** Do not pull pavement with machines until it is completely broken and separated from remaining pavement.
- (iv) **Damage to Adjacent Pavement:** Do not disturb or damage the adjacent pavement. If the adjacent pavement is disturbed or damaged, remove and replace.
- (v) **Concrete Driveways:** Remove concrete driveways to their full width. Prior to replacing concrete pavement, make a final cut using a rotary saw. Unless otherwise directed by the MCR, all driveways shall be replaced from the driveway joint at the street to the nearest undisturbed construction joint. If no construction joint exists between the location of the cut and the right-of-way line, replace concrete from the street joint to a location twelve (12) inches back from the edge of the original cut.
- (vi) **Asphalt Driveways and Pavements:** When replacing the asphalt, remove the pavement twelve (12) inches back from the edges of the original cut. Use jack hammers or other suitable tools. Replace driveways, sidewalks, and curbs with the same material and to the same dimensions as existing.

(h) **Concrete Pavement and Driveways.** All concrete, so replaced, shall be the same thickness as that removed or 6 inches (4 inches for driveways), whichever is greater, and shall be installed over a properly backfilled and compacted trench. The Contractor shall protect the concrete and cure as per the requirements of Section 5.6, "Concrete, Aggregates and Reinforcing Steel". All pavements, including driveways, shall be Class "A" concrete. Reinforcing steel equivalent to that removed shall be used; welded wire mesh is to be used in all installations as a minimum. All edges, grooves and joints of the concrete shall be tooled to produce a finished job similar to the adjoining concrete.

(i) **Asphalt Pavement and Driveways.** Backfill trench, with dense graded base material, to a smooth and even grade at the proper depth to allow adequate space for binder coarse and/or pavement. This material shall be tamped with acceptable and approved mechanical tampers in layers not to exceed 10 inches (loose measure), to a minimum compaction of 95% in accordance with AASHTO T 99. Where required, the top 6 inches of subgrade shall be compacted to 100%. Backhoes, rubber tired loaders, bulldozers, etc. are not acceptable tamping devices. Where paving is not to be immediately patched, fill trench to finish grade within 24 hours of excavation with a layer of cold-mix, minimum 1 ½" thick, and maintain until pavement patching is complete.

Bituminous binder layer shall be placed in accordance with Section 414 of the State of Alabama Highway Department Standard Specifications for Highway Construction (SAHD Specifications). Minimum thickness of binder layer shall be 2 inches for two lane roads and 2 ½ inches for roads

of three or more lanes. The asphalt binder shall extend a minimum of 9 inches on either side of the trench and shall be compacted by rolling to provide a smooth, uniform surface 1 to 1 ½ inches below the finish grade.

Bituminous asphalt paving shall be placed, to a minimum depth of 1 ½ inches, in accordance with Section 416 Mix A of SAHD Specifications.

The finished surface of the new compacted paving shall be flush with the existing surface and shall conform to the grade and crown of the existing pavement. The surface of the new pavement shall be smooth to within 1/4 inch when checked using a straightedge.

Asphalt shall not be applied to wet material or during adverse weather conditions. Do not place asphalt upon frozen surfaces or when the temperature is below 40 degrees, without express written approval of the MCR.

(j) **Gravel Roads and Driveways.** After the trench has been properly backfilled and compacted, where a gravel roadway or driveway has been cut, crushed rock material shall be placed on the full width of the trench (plus any other areas disturbed by the construction) and shall be to a grade approved by the MCR. Gravel shall be spread, leveled, and graded to conform to existing grades and surfaces.

5.3 INSTALLATION.

(a) Laying Pipe

- (i) **Inspection.** No water mains shall be covered until visually inspected by MCR. Any mains covered prior to inspection shall be uncovered at the Contractor's expense.
- (ii) **Earth Trenches.** Grade the bottom of the trench to a true line. Lay the pipe in clean bedding material, free of rock, organic, and other unsuitable materials. Earth trench excavation and backfill requirements are described in Section 5.4 and illustrated in Appendix D, Figure 1.
- (iii) **Rock Trenches.** Bed the pipe in at least six inches of clay or granular bedding material. Backfill with the same material to at least two feet above the pipe. Rock trench excavation and backfill requirements are described in Section 5.4 and illustrated in Appendix D, Figure 2.
- (iv) **Drainage Crossings – ditches/streams/rivers.** Ductile iron pipe shall be laid under bottom of drainage ditch/stream/river and concrete poured on pipe, unless otherwise specified. Detailed requirements for drainage and creek crossings are presented in Section 5.5 and depicted in Appendix D, Figure 3.
- (v) **Drainage Crossings – pipes/culverts.** When crossing under drainage pipe, ductile iron pipe shall be laid a minimum of 18" under the drainage pipe. No fittings or taps shall be placed under drainage pipes.
- (vi) **Along Roads.** Water lines are to be laid behind existing ditches or future drainage ditches, close to right-of-way line. Where there is

curb and gutter and sidewalks, water main is to be laid between sidewalk and right-of-way line. Keep a minimum distance of 2 feet from sidewalk.

- (vii) **Tracer Wire.** All PVC pipe shall have tracer wire #14 solid copper (insulated). Tracer wire is to be brought up outside valve boxes and placed on top center of PVC pipe; use duct tape to hold in place. Tracer wire is not required for ductile iron pipe.
- (viii) **Dead End Mains.** Dead end mains are to be anchored using one full joint of ductile iron pipe with concrete and restrainer gland as illustrated in Appendix D, Figure 4.
- (ix) **Fittings and Valves.** Coatings to be fusion – bonded epoxy color red oxide; fittings and valves are to be mechanical-joint type. Mega lugs are to be used on all mechanical joints, as a way of fastening the connection. Concrete thrust blocking will be required in addition to mega lugs except on fire hydrant tees. When starting off with a full joint of PVC pipe, always cut off bevel end of PVC pipe for a better fitting mechanical joint.
- (x) **Open Cut Roads.** Ductile iron pipe is to be used on all roadway crossings; this includes new roads and existing roads. Appendix D, Figure 6 illustrates roadway crossings.
- (xi) **Depth of Cover.** All water mains shall have a minimum cover of 30 inches. Unless installed under storm drains, no water mains shall exceed a maximum cover of 54 inches measured from final grade. Service lines shall have a minimum cover of 18 inches.
- (xii) **Protection of Pipe.** The Contractor shall exercise care in keeping foreign materials out of main before and during installation. Should this requirement not be adhered to, pipe shall be removed, cleaned and replaced, or pipe shall be cleaned by running a series of polyfoam pigs through the pipe line, at the Contractor's expense. At the end of each day's work, all open ends of piping shall be sealed with plugs designed to prevent any foreign matter from entering the pipe. Plywood barriers are not acceptable for this purpose.
- (xiii) **Joint Deflection.** Pipelines intended and/or shown to be laid in a straight line shall be laid straight with no deflection at the joints. No deflection will be allowed unless necessary due to grade, curves, or to avoid obstructions. Should it be necessary to deflect pipe from a straight line, the maximum amount of deflection allowed shall not exceed the values listed in the following table or as recommended by the manufacturer.

PIPE SIZE	MAX. JOINT DEFLECTION	MAX. DEFLECTION PER JOINT
3" – 6"	5°	21" (20' JOINTS)
8" – 12"	5°	19" (18' JOINTS)
14" – 16"	4°	15" (18' JOINTS)
18" – 36"	3°	11" (18' JOINTS)

(b) **Thrust Restraint.** All tees, plugs, caps, bends, or any other locations where unbalanced forces exist, shall be anchored by adequate thrust blocking as defined herein. Appendix D, Figure 7 depicts the thrust restraint requirements for bends and tees. Concrete for thrust blocking shall be Class B concrete (3,000 PSI) and shall be placed against undisturbed earth. SAKRETE is not acceptable for thrust blocking. A minimum of one-third (1/3) cubic yard of concrete for each thrust block shall be used. Where weak soil conditions or higher test pressures are encountered, the bearing area of each block will be increased as required by the MCR.

The Contractor shall insure that all bolts, nuts, and set screw rings are left clear of concrete thrust blocking for future access. Plywood or other suitable means of confining the concrete and keeping the bolts and nuts clear shall be used, and any excess concrete shall be removed at the Contractor's expense.

Vertical bends, at locations where the installation of concrete thrust blocks is difficult, shall be secured by the use of MEGA LUG retainer glands and/or THREADED RODS and a minimum of 100' ductile iron pipe restrained by locking gaskets.

Thrust ties may be required in some instances by the MCR. Where so required, the Contractor shall provide threaded rods, mild steel (A-36) or equivalent, with a minimum diameter of 3/4 inch. Threaded rods shall be installed using approved harness assembly or special bolts or plates so designed for this purpose.

Minimum number of threaded rods shall be as follows:

<u>PIPE DIAMETER</u>	<u>TIE RODS REQUIRED</u>
4" TO 10"	2
12" TO 14"	4

Following installation, threaded rods and nuts shall be coated with coal-tar epoxy paint for protection from rust and corrosion.

(c) **Tapping Existing Water Mains.** All 6" and larger taps shall be made by Madison County Water Department with a **minimum notice of forty-eight (48) hours.** The Contractor shall do all excavation and install the tapping sleeve and valve in accordance with the specifications. In addition, the Contractor shall do a pressure test on the tapping sleeve and valve prior to MCWD tapping the water main.

(d) **Valve Boxes.** Valve boxes shall be set vertical and concentric with valve stem. Appendix D, Figure 8 depicts the valve box installation. Backfill and compact area around valve body with gravel or other suitable and approved granular material before setting valve box

so that valve box does not rest directly on valve body or pipeline. Backfill around valve boxes shall be the same as that specified for adjacent pipe and shall be carefully and thoroughly compacted. Care should be taken to insure the valve box is not displaced from proper alignment or grade. Misaligned valve boxes shall be excavated, plumbed, and backfilled, at the Contractor's expense.

Under no circumstance shall DUCTILE IRON or PVC PIPE be used for a valve box or extension. Valve boxes must be brought to proper height with the use of a valve box extension. Any valves installed at a depth greater than 48", measured from final grade to top of valve operating nut, shall have a valve stem riser installed prior to backfill. The riser shall extend to a depth of one foot below final grade. All valve boxes shall be constructed with concrete pads, two-foot square by 4" thick concrete class B, or a 24 inch round valve box pad.

(e) **Fire Hydrants.** Appendix D, Figure 9 depicts the typical fire hydrant installation. Fire hydrants shall be installed in the locations depicted on the drawing(s). Unless otherwise specified, all fire hydrants shall be installed complete with a 6" gate valve and valve box.

Control valves shall be anchored directly to fire hydrant tees. Valves and valve boxes shall be installed as per specifications. Unless otherwise specified, hydrants may be connected to control valves with an anchoring assembly or with mega lug retainer glands.

Contractor shall furnish solid concrete blocks, 4" thick by 16" long, to be installed under fire hydrant base. Hydrant shall be carefully placed on base block to prevent breaking and to hold hydrant plumb.

A minimum of four (4) cubic feet of washed gravel or crushed stone shall be placed around the base of all fire hydrants, to a point at least 12" above weep holes, in order to allow for proper drainage of hydrant barrel after closing. Gravel shall be installed a minimum distance of 12" in all directions from hydrant drainage holes. Pug mix will not be acceptable for this application. Additionally, all hydrants shall have caps on each nozzle, with chains tied together and secured to hydrant barrel to prevent loss of caps. All caps and threads shall be cleaned and greased by the Contractor.

All fire hydrants shall be located so as to provide complete and unobstructed access for a minimum of five (5) feet in all directions. No fire hydrants are to be placed in sidewalks. Place hydrants a minimum of 3 feet from sidewalk. Pumper nozzle shall be facing the street and shall be no less than 18 inches, and no more than 24 inches, from final ground elevation. Safety flange shall be approximately 2 to 3 inches above finished ground level to provide access to bolts and nuts.

Hydrant extensions, where required, shall be installed by the Contractor and considered incidental to fire hydrant installation. Contractors are encouraged to request taller or shorter hydrants before installation to avoid delays and extra work involved with addition of extensions. Where hydrant risers are required, the Contractor shall inform himself of the type of hydrant riser to be used and its proper installation, taking special precaution to insure the breakaway flange of the riser is installed next to the hydrant barrel and not below grade.

The Contractor shall check each fire hydrant installation with a level to insure it is installed plumb. Any fire hydrants improperly located, not plumb, or improperly installed and backfilled shall be removed and properly reinstalled at the Contractor's expense.

5.4 TRENCH EXCAVATION AND BACKFILL

(a) Trench Excavation. All excavations shall be made to the lines and grades as established by the drawings and shall be open cut through whatever material encountered. The Contractor will determine the final alignment in the field with the approval of the MCR. In areas where soil conditions permit normal excavation of the trench, the sides shall be cut as nearly vertical as possible from the bottom of the trench to a point at least 12 inches above the top of the pipe. For all pipe sizes up to and including 24" diameter, a minimum clearance of 6 inches on each side of the pipe is required for proper placement and compaction of the bedding or backfill material. Pipe diameters 30" and above shall require 9 inches clearance on all sides. The maximum trench width measured at the top of the pipe shall be the outside diameter of the pipe plus 24 inches.

The sides of the excavation shall be cut at such a slope that will prevent caving; the trench shall be adequately supported and the safety of workers provided for as required by the most recent standards adopted by OSHA. Any sheeting or bracing used in area of unsuitable material, required to protect adjacent structures, property, workers or the public, shall be left in place until the excavation has been backfilled to a sufficient depth to prevent caving.

Trench widths shall be confined to dedicated rights-of-way or construction easements, unless special written agreements have been made with the affected property owner. Place all excavated materials within easements or rights-of-way, and do not obstruct any public or private roadways or streets.

The convenience and protection of the general public and, more particularly, the residents along the proposed path of the pipelines shall be considered of paramount importance and shall be provided for by the Contractor in an adequate manner, satisfactory to the MCR. All trench excavations shall proceed in a systematic manner so as to result in a minimum of inconvenience to the public. Trench excavation shall not advance more than 200 feet ahead of pipe laying and backfilling work without express permission of the MCR. The Contractor shall be responsible for the safety conditions of all open and backfilled trenches.

The Contractor shall completely backfill and clean up all trench excavations immediately after each section of pipe has been inspected (or tested) and approved. The MCR may instruct the Contractor to cease excavation operations on new sections of pipeline until such time as completed sections are completely backfilled, cleaned up and landscaped. Such clean-up operations may include, but shall not be limited to, the removal of all construction debris and excess excavated materials, restoration of all fences, ditches, culverts, signs or other similar items damaged by the construction and the restoration of all driveways, roads and other gravel, concrete or paved surfaces.

(b) Trench Bottom. Excavate the trench to the grades shown or established by the MCR, with proper allowance for pipe thickness and pipe base or special bedding where

required. If the trench is excavated below the required grade, the Contractor will correct any part so excavated, at no additional cost to the Owner, with approved bedding materials. Place the bedding material over the full width of trench in compacted layers not to exceed 6 inches deep.

When, in the opinion of the MCR, the existing material in the bottom of the trench is unsuitable for supporting the pipe, excavate below the flow line of the pipe to suitable material or as directed by the MCR. The Contractor shall backfill the trench to the specified pipe grade with number 57 stone, free from dirt or other organic matter. The use of pug mix for backfill in this area will not be allowed. Place and compact the stabilization material over the full width of the trench in layers not to exceed 6 inches.

The trench bottom shall be shaped so as to provide uniform bearing of the pipe on undisturbed earth throughout its entire length. Bell holes shall be dug to aid in securing uniform support of the pipe.

(c) Excavation in Rock. Whenever trench excavation is required in rock, the requirements of this paragraph shall govern. All rock encountered in trench excavation shall be removed to a depth of 6 inches below the bottom of the pipe barrel. The undercut shall be backfilled with crushed #57 stone. In no case shall solid rock exist within 9 inches of the finished pipe line on any side.

(d) Removal and Replacement of Topsoil. Where trenches cross lawns, cultivated fields, pasture lands, or other areas where reasonable topsoil exists, remove and stockpile the entire depth of topsoil or the top 12 inches, whichever is less, from the entire trench width; do not mix with the remaining excavated material. Replace topsoil over the backfilled trench to the original depth removed. If no topsoil has been stockpiled or such topsoil is unsuitable, the Contractor shall acquire additional topsoil, haul and place to a minimum depth of 6 inches, at the Contractor's expense.

Any imported topsoil used by the Contractor shall be suitable, fertile sandy loam, and shall be free of clods, roots, gravel and all other inert material. It should also be free of weeds or other undesirable vegetation and/or seed. The Contractor shall remove, at his own expense, all such growth, both surface and root, which may appear in the imported topsoil within the warranty period.

(e) Removal of Water. The Contractor shall at all times provide and maintain the necessary equipment and means to remove all water from excavated areas. All excavated areas shall be kept free of water while any work is in progress. The Contractor shall take precautions to prevent the displacement of structures or pipelines as a result of accumulated water. The Contractor will not, under any circumstances, permit or allow water to enter the construction area of any other contractor.

Bedding material or pipe shall not be placed in wet or unstable trenches. Soil that cannot be properly dewatered shall be excavated, and dry material shall be tamped in place to such a depth as may be required to provide a firm trench bottom.

All water removed or diverted from excavations shall be disposed of in a manner which will prevent damage to adjacent property or any flooding of streets or property. Disposal of trench water through the pipeline under construction shall not be allowed.

(f) **Excavation in Paved Driveways.** Where trenches must cross or otherwise be excavated in driveways, curb and gutter, or sidewalks, the removal of pavement or concrete shall be performed in a neat and workmanlike manner. See Section 5.2 for specifics on cutting, removing, and replacing pavement materials. All paving materials shall be removed before starting the trench excavation, and these materials shall not be used in any fill or backfill.

All excavated materials shall be placed so as to cause as little interference to traffic as possible. The Contractor shall at all times keep a sufficient width of the roadway clear of dirt and other material to allow the free flow of traffic. The Contractor shall backfill these excavations immediately after pipe laying to minimize traffic congestion or traffic hazards.

The Contractor shall make every effort to complete construction and allow immediate access to adjacent property at all driveway entrances located along the roads. Owners or tenants of properties, where access and/or entrance drives are located, shall be notified at least eight (8) hours prior to the time the construction will be started and informed as to the length of time driveways will be closed (which shall not exceed six (6) hours).

Following pipeline installation, all trenches in roadways, rights-of-way, or other areas where traffic will pass over the trench shall be maintained in such a condition as to allow for normal traffic to pass over such trenches in a safe manner.

Whenever flagmen or other guards or required are necessary for safety, they shall be furnished with approved safety clothing and any other regulation traffic control devices as may be required by regulation or deemed necessary by the Contractor.

(g) **Bedding.** All water mains shall be installed upon a firm and solid bedding, no less than six inches in depth, and smoothly graded so as to support the entire length of pipe to be installed. Bell holes shall be dug at each bell to insure that the remainder of the pipe barrel is fully supported by the bedding. Bedding may be classified as follows:

- (i) **Class "1" Bedding.** Bedding materials are those on site; excavated earth may be used for bedding.
- (ii) **Class "2" Bedding.** Bedding materials shall be composed of gravel materials, #57 stone. Substitution of alternate bedding materials will be approved only in individual cases and only by the MCR, at the specific request of the Contractor.
- (iii) **Class "3" Bedding.** Bedding materials shall be concrete and reinforcing steel and shall meet all requirements of Section 5.6, "Concrete, Aggregates, and Reinforcing Steel". Excavation shall be carried to the bottom of the concrete as shown in the detail drawings. Where excavation is carried to a depth below the bottom of the concrete for any reason, the space may be filled with either Class "2" or Class "3" bedding material, unless otherwise specified.

Generally, Class "1" bedding is sufficient for the majority of pipe installations. In areas where rock excavation is required, where unstable soils are encountered, where specified on the plans or elsewhere in the Contract Documents, or where directed by the MCR, Class "2" bedding will

be required. All Class "3" bedding requirements will be clearly labeled on the drawings or specified in the Contract Documents.

(h) Backfilling Pipeline Trenches. The Contractor shall not begin backfilling before the MCR has inspected the grade and alignment of the pipe, the bedding of the pipe, and the joints between the pipes. Contractor to backfill to finished grade with good earth, sand or gravel (select material), free from large rocks or hard lumpy materials. Large rocks shall be defined as any larger than 3 inches in diameter. No materials of perishable, spongy or otherwise unsuitable nature shall be used in backfilling. It is essential that the completed backfill be done in such a manner as to minimize voids in the backfill.

The Contractor shall place the specified backfill material at approximately the same rate along both sides of the pipe and compact by tamping, in layers not to exceed 3 inches, up to the horizontal centerline of the pipe, with a minimum depth of 6 inches. The intent is to cradle the pipe so that the full length is uniformly supported on firm bedding and the weight of the pipe and backfill is borne uniformly by the lower half of the pipe barrel. Special attention should be given to the backfilling and tamping procedures to insure that no voids or uncompacted areas occur beneath the pipe. After backfilling and tamping to the pipe centerline, the remainder of the pipe zone will be placed and compacted in maximum of 6 inch layers. After this, fill and compact the trench as specified below, depending upon the location of the Work and danger from subsequent settlement.

- (i) **Backfilling in Unimproved Areas.** From an elevation of one foot above the top of the pipe to the surface of the ground, backfill may be deposited by front end loader, bulldozer, or other suitable equipment. Depositing in layers or tamping will not be required. Sufficient surplus excavated material may be neatly rounded over the trench to compensate for subsequent settlement.
- (ii) **Backfilling in Lawns or Other Improved Areas.** Backfill may be placed from an elevation of 10 inches above the top of the pipe to one foot below the ground by any suitable equipment. The top 10 inches of backfill shall be placed and compacted in two lifts of 5 inches each. Topsoil shall be placed above the selected backfill to finished grade.
- (iii) **Backfilling Beneath Driveways, Roads, and Parking Lots.** From an elevation of one foot above the top of the pipe to one foot below the bottom of the pavement, number 57 stone shall be used. From one foot below the bottom of the pavement, 1 ½ crushed stone (also referred to as crusher run) shall be used, deposited in layers of not more than 6 inches. Each successive layer shall be well compacted by manually operated tampers. As an option to this method, the Contractor may elect to install granular material (such as "pug mix") at his expense.

(i) Disposal of Excavated Materials. The Contractor shall dispose of, at an off-site location, all excess excavated material that cannot be used or is not suitable for backfill.

5.5 CREEK AND DITCH UNDERCROSSINGS

(a) **Permits.** All necessary permits for any undercrossings will be obtained by Madison County. The Contractor shall be responsible for insuring that all crossings are installed in accordance with the requirements of the permits. The Contractor shall keep copies of all undercrossing permits, obtained by the Owner, at the job site; the copies shall be readily available for reference in accordance with individual permit requirements. The required method for creek undercrossings will be specified on the project drawing.

(b) **Encasement of Pipe in Concrete.** Where specified on the construction drawings, the Contractor shall place concrete backfill around pipelines. The pipe will be supported on solid concrete blocks. The blocks will be positioned so the minimum clearance between the bottom of the pipe and bottom of the trench is 6 inches. Class A concrete will be used to encase the pipe. The minimum dimensions are depicted on the detailed drawing. Concrete encasement so placed shall be allowed sufficient time to reach initial set before any additional backfill material is placed in trench. Concrete shall be placed in such a manner that no dirt or foreign material becomes mixed with the concrete. The remainder of the ditch shall be filled with rip-rap materials. In no case shall materials be placed in the trench which will impede the flow of water in the creek or stream.

(c) **Erosion Control.** Madison County will obtain any required stormwater permits. Utilize erosion control methods as indicated on the attached drawing(s). Specifications providing planning and design considerations, maintenance guidelines and installation requirements will also be attached for any requested erosion control methods.

Whenever working along waterways, rivers, creeks, streams, wetlands, floodplains, or other such areas, a strict erosion and sediment control program shall be instituted and maintained for the duration of the project. It is especially important due to the nature of such a project, with close proximity of the Work to the water body, to take effective measures to prevent, to the maximum extent possible, the deposition/disposal of materials, waste, debris/litter, or liquids from falling or being placed into the water body. Properly dispose of any floating, submerged, or offsite deposited construction waste resulting from construction activities.

Temporary or permanent stockpiling and side-casting of excavated material within the banks of the water body, or disposal of material into water of the State from dredging/disturbances is prohibited, unless specifically approved in writing by the Alabama Department of Environmental Management.

Minimize, to the extent practicable, the width of any access through a stream bank. When construction disturbance is complete, restore the stream bank access to original contours; stabilize, and, unless structural forms of stabilization, such as stone rip-rap, are indicated, vegetate with annual and perennial vegetation consistent with pre-disturbance conditions or such alternate condition that provides an equal protection of water quality.

Unless authorized by the Alabama Department of Environmental Management, equipment, machinery, vehicles, or pollution prevention/abatement equipment, or other construction materials, shall not be left unattended within the watercourse.

All erosion control methods shall be conducted in accordance with specifications contained in the Alabama Handbook for Erosion Control, Sediment Control, and Stormwater Management on Construction Sites and Urban Areas, which specifications and requirements shall be made a part of these specifications as if contained herein in their entirety.

5.6 CONCRETE, AGGREGATES, AND REINFORCING STEEL

(a) Concrete. Concrete shall be composed of Portland Cement, fine and coarse aggregate, and water, with the following minimum requirements:

Class "A" - 6 ½ sacks cement/cubic yard, slump 2 - 4 inches,
maximum water/cement ratio, by weight = 0.50.

Class "B" - 5 ½ sacks cement/cubic yard, slump 2 - 4 inches,
maximum water/cement ratio, by weight = 0.55.

Portland Cement shall conform to ASTM C-150, Type I, and one cubic foot sack of Portland Cement shall be considered as 94 pounds in weight.

Class "A" concrete shall be proportioned so as to have a minimum 28-day compressive strength of 4,000 psi; and Class "B" shall have a minimum 28-day strength of 3,000 psi. High early strength cement may be used if approved by the MCR, in which case the above compressive strengths shall be attained at the age of seven days.

Class "B" concrete shall be required for driveways, sidewalks, curbs and gutters and concrete thrust blocking unless otherwise specified or shown on plans. For other structures, class of concrete shall be specified on plans or elsewhere in specifications, or shall be determined by the MCR.

The equipment for producing and delivering ready-mix concrete shall conform to the requirements of ASTM C94 "Standard Specifications for Ready-Mixed Concrete", latest revision.

(b) Concrete Admixtures. Where specified hereinafter, an air entraining agent shall be added to the concrete mix in accordance with ASTM C-260. The admixture shall be introduced in such quantities as to produce the specified amount of air entrainment.

No other admixtures, such as retarders or plasticizers, shall be used unless so directed by the MCR. Any proposed admixtures shall be submitted and approved by the MCR prior to being used with any concrete.

(c) Aggregates for Concrete. Aggregates used in concrete mix shall conform to ASTM C-33 and shall consist of clean, hard, durable, uncoated particles free from lumps of clay, thin, or elongated pieces, and organic or other injurious matter.

Fine aggregates shall consist of sand, or a mixture of sands, and not more than 50% stone screenings. Coarse aggregate shall be well graded from coarse to fine to produce a workable concrete mix, as follows:

Sieve Size	% Retained (by weight)
1 1/2"	0
1"	0-5
3/4"	25-50
3/8"	75-90
No. 4	95-100

(d) **Reinforcing Steel.** Steel reinforcement shall be free from rust, scale, mortar, dirt, and other objectionable coatings. All reinforcing steel shall be spaced in accordance with the requirements of ACI Code 318, latest revision, and in accordance with details shown on the plans. The steel shall be properly secured in position by concrete, non-metallic, or other approved chairs, spacers, or ties. Splices shall be made only as shown on the plans or as directed by the MCR. All reinforcing steel bars shall conform to ASTM A-615 and welded steel wire fabric shall conform to ASTM A-185.

No reinforcing steel shall be within 2" of finished surface, shall any metal which is connected to or in contact with any reinforcing steel.

(e) **Forms.** All forms shall be designed so they may be removed without damage to the concrete. They shall fit together sufficiently tight to prevent leakage of mortar and sufficiently strong, braced, and tied, so as to maintain initial position and shape throughout pouring operations and initial curing period.

The inside of all forms shall be coated with a non-staining oil or other approved material to prevent concrete from adhering to form. Tar paper or oil which will discolor concrete shall not be used.

(f) **Placing Concrete.** MCR shall be notified at least one full working day before placing any concrete, to permit inspection of forms, reinforcing, and other associated work. Authorization to place concrete shall be secured from the MCR before placing concrete in any portion of any structure. Any concrete placed in violation of this provision or in the absence of the MCR, shall be removed and renewed if so ordered.

Placement of concrete shall conform to the requirements of ACI 304 and ACI 318, unless modified herein. All forms and fill below concrete shall be dampened before placing concrete. All concrete shall be placed in daylight and no portion of the Work shall be started which cannot be completed in daylight.

No concrete shall be placed when the temperature is below 40 degrees F without written permission of the MCR. No concrete shall be placed against frozen earth or forms and reinforcement with frost or ice present. Every effort shall be made to maintain a concrete temperature of below 90 degrees F at time of placement.

Concrete shall be compacted and vibrated both during and immediately after depositing. All air shall be expelled and coarse aggregates worked away from surface, face of forms, and under and around all reinforcement. Do no over-use vibrator and segregate aggregates, bringing water to surface.

Finish and cure concrete in conformance with the applicable requirements of ACI 614 or this specification. Curing compounds are acceptable in place of keeping concrete surface moistened. Generally, unless otherwise approved, a light broom finish is desired.

The MCR shall be notified to inspect the concrete immediately following the removal of forms. Any holes or imperfections discovered shall be promptly repaired with grout. Where grinding is required to remove metal projections, notify the MCR so inspection may be performed before the application of grout, in order to insure no metal is left within 1" of the finished concrete surface. The exposed surface shall be left smooth, even and uniform in color. Should bulges, sags, or honeycombs exist to such an extent that they cannot be satisfactorily repaired, the entire section shall be removed and renewed. A final inspection of the finished concrete shall be conducted by the MCR prior to the placement of any backfill. Any backfill placed without the MCR approval shall be removed, at the Contractor's expense, to allow for the concrete surface to be inspected.

Any and all cracks or imperfections developing at any point of the Work shall be thoroughly repaired in a manner satisfactory to the MCR.

5.7 PRESSURE TESTING REQUIREMENTS

(a) **General.** As soon as a continuous valve section of new water main has been installed, the Contractor shall proceed immediately to complete flushing and pressure testing as specified herein. However, no pressure test shall be conducted until all taps, including service taps, have been installed and all thrust blocking has been in place for a minimum of five days.

The Contractor shall furnish all labor, materials, tools and equipment necessary to fill and flush the lines and then seal the main for testing. The pipe shall be slowly filled with water and all air expelled from the pipe. The pipe shall then be allowed to stand for 24 hours, after which it shall again be checked for any trapped air. All new lines shall be flushed, until clear water is observed, at a minimum velocity of 2.5 feet per second. It shall be the responsibility of the Contractor to provide for adequate disposal of flushed water and to protect existing structures or landscaping from damage from flushing operations. All mains shall be flushed with a full sized flushing assembly unless otherwise approved.

All pressure tests shall be scheduled at least 24 hours in advance and shall be conducted in the presence of the MCR. No pressure test shall start at a time which will result in the completion time being later than 3:00 p.m., or which will result in a completion time later than 1:00 p.m. on Friday afternoon. The duration of each pressure test shall be a minimum of 2 hours for uncovered pipes and 6 hours for pipelines which have been backfilled. All valves within the section being tested shall be open during the pressure test, including fire hydrant control valves. **The new mains shall be tested at 160 psi.**

The Contractor shall furnish a gauge capable of reading well in excess of the test pressure; the

said gauge shall be in new condition and graduated in one (1) or two (2) psi increments. MCWD will furnish a digital pressure gauge for recording each pressure test. The pump suction shall be metered or placed in a graduated container such that the amount of water required, maintaining test pressure, may be accurately measured.

(b) **Testing Procedures.** The following testing procedure shall be used:

- (i) Pump line to required test pressure and record gauge pressure.
- (ii) Monitor gauge continuously and record pressure after 30 minutes. If, at any time during the pressure test, the pressure drops more than 5 psi, pump back to test pressure and record amount of water required restoring system to test pressure.
- (iii) Continue until completion of required test period; then total the amount of water used to maintain pressure within 5 psi of required test pressure. This amount shall be defined as leakage.

(c) **Allowable Leakage.** Allowable leakage shall be defined as 10 gallons per 24 hours, per mile of pipe, per inch of nominal diameter. Any leakage greater than the calculated allowable leakage for a test section shall constitute a failing test, and will require the Contractor to find and eliminate the leak or leaks. In addition, any observed leaks shall be stopped, regardless of test requirements or results. All costs of finding and repairing leaks shall be borne by the Contractor.

As an alternate, the following formula may be used to calculate the allowable leakage:

$$L = \frac{SD\sqrt{P}}{148,000}$$

Where:

L = Allowable leakage in gallons per hour

S = Length of pipeline in feet

D = Nominal diameter in inches

P = Average test pressure during test in psig

Generally, short valve sections shall be tested independently, but the Contractor may request that several sections be combined on complex projects involving small diameter mains in short sections. In this case, the allowable leakage for each section shall be computed separately; the smallest value obtained shall be used for the entire test section, in order to eliminate the possibility of a major leak at a single location. All mains 10" diameter or larger shall require a passing pressure test on each individual valve section.

5.8 DISINFECTION AND SAMPLING

(a) **General.** Following acceptable completion of the pressure test, water mains shall be disinfected, by the Contractor, in accordance with AWWA specifications governing water main disinfections. Bacteriological samples shall be collected from each dead end main and at other locations as may be required by MCR.

The Contractor shall provide an adequate number of temporary taps, usually 1", for the injection of a disinfecting agent, collecting bacteriological samples, and pressure testing, as shown on the

project drawing. At a minimum, disinfection taps are required at each tie point, and sampling taps are required at a minimum of 2 feet from each dead end main and along each valved section of main. Following successful disinfection and sampling, the Contractor shall remove all materials and cap all temporary corporation stops. The cost of all materials, equipment, and labor shall be borne by the Contractor.

The Contractor may be required to install temporary blow-offs at ends of all mains, as directed by the MCR, and must remove these installations upon successful disinfection of main. The Contractor shall properly dispose of flushing water and protect any structures, subgrade or landscaping as required. The Contractor shall obtain and apply sufficient quantities of a reducing agent to thoroughly neutralize the remaining chlorine residual. The quantities and types of neutralizing chemicals to be used shall be in accordance with AWWA C651, latest revision, and shall conform to all Federal, State, and local regulatory requirements.

Madison County personnel will collect the samples for bacteriological testing. Should any mains test bad or unacceptable, more samples must be taken. The Contractor will be responsible for re-disinfecting the main(s). MCR will then resample the main(s). Should bad samples again be collected after two tries to disinfect, it shall be assumed that there is a problem with the main, and the Contractor shall be required to determine the cause of the problem. The Contractor may at any point, when trying to obtain satisfactory results from a main which has repeatedly failed health samples, at his own expense, attempt to disinfect mains and hire an independent, approved laboratory to collect and analyze samples under the supervision of MCWD.

(b) Disinfection Method. The contractor shall disinfect the water mains in accordance with the most recent AWWA specifications and using the continuous-feed method. ANSI/AWWA C651-05 is the reference for the procedure below, which to be used for disinfecting all water mains:

- (i) **Preliminary flushing.** Before the main is chlorinated, it shall be filled to eliminate air pockets and flushed to remove particulates. The flushing velocity shall not be less than 2.5 ft/sec. (Flushing is not a substitute for using preventative measures during construction. For 24-inch diameter mains, an acceptable alternative to flushing is to broom-sweep the main.)
- (ii) **Chlorinating the main.** Water supplied from a temporary backflow-protected connection to the existing distribution system shall flow at a constant and measured rate into the newly installed main. In the absence of a meter, the rate may be approximated using a Pitot gauge in the discharge, measuring the time to fill a container. At a point no more than 10 feet downstream from the beginning of the new main, water entering the new main shall receive a dose of chlorine fed at a constant rate such that the water will not have less than 25mg/L of free chlorine. To ensure that this concentration is provided, measure the chlorine concentration at regular intervals in accordance with the procedures described in the most current edition of *Standard*

Methods for the Examination of Water and Wastewater or AWWA Manual M12, or using appropriate chlorine test kits. Chlorine application shall not cease until the entire main is filled with heavily chlorinated water. The heavily chlorinated water shall be retained in the main for at least 24 hours. After 24 hours, the treated water in all sections of the main shall have a free chlorine residual no less than 10 mg/L. The Contractor must either document the free chlorine residual and provide the documentation to the MCR or test the free chlorine residual in the presence of the MCR. The Contractor shall then flush the main and request the water department obtain samples for bacteriological examination.

Direct-feed chlorinators shall not be used for the application of liquid chlorine. The preferred equipment for applying liquid chlorine is a solution-feed vacuum operated chlorinator and a booster pump. Feed lines shall be made of suitable material to withstand corrosion caused by the chlorine and high pressures created by the booster pumps.

5.9 RECONNECTING SERVICE LINES AND METER BOXES

(a) General. The Contractor shall connect all existing services to the new water main prior to pressure testing and bacteriological testing. During pressure testing, leave service taps exposed to observe possible leaks. Services can be transferred to the new main once all test results are satisfactory. Appendix D., Figure 10 depicts a typical meter installation. Materials, provided by Madison County, will be used to connect the existing meters to the new water main. These materials include tapping saddle, corporation valve, service tubing, and curb stop. Contractor is responsible for furnishing the encasement pipe for the long side services.

The Contractor shall attempt to bore each long side service. If boring fails due to challenging subsurface conditions, the Contractor may open-cut the road to install the long side service. After multiple bore failures, the Contractor may open-cut the remaining long side services.

(b) Installation Requirements.

- (i) Service saddles with corporation stops shall be used on all water mains.
- (ii) Service lines shall be installed perpendicular to mains using shortest possible route. All service lines shall be continuous; **no splices** will be allowed. In a case where the service line is damaged or must be extended during construction, the entire service line must be replaced.
- (ii) 2.5" encasement pipe shall be installed to protect services, refer to Appendix D, Figure 10.
- (iv) There are to be no more than two (2) taps at one location, and these must run in the same direction.

- (v) The corporation valve must be installed with the operating nut on top.
- (vi) Services lines under roadways shall have a minimum cover of 18 inches.
- (vii) Contractor shall connect to existing meter. If existing meter is deeper than 15 inches, the Contractor is to adjust the height of meter. No meters shall be deeper than 15 inches.
- (viii) Meter boxes are to be installed flush with existing grade. Curb stops shall be placed just inside of meter box with operating nut turned up.
- (ix) The Contractor shall backfill under mains and corporation valves in a manner to insure there are no voids under the mains or corporation valves. The fill material shall be added in 3 to 6 inch layers and placed under the corporation valves. After 12 inches of material is placed over the corporation valves, then the backfilling procedures, as described in Section 5.4, shall apply.

(c) Replacement of Meters. The Contractor shall install new meters and backflow preventers for every household. The meters and backflow preventers will be provided by Madison County. The Contractor must coordinate with the customer according to the instructions in Paragraph (d) below. Old meters and backflow preventers are to be returned to Madison County's warehouse as referenced in Section 4.16.

(d) Coordination with Customers. The Contractor must inform the customer of a planned water outage no less than 24 hours before the planned outage occurs. The duration of the outage shall be no longer than four (4) hours for each residence. Customers shall also be notified of possible air in customer's water lines when those conditions may exist. Customer coordination is required when work to be performed to the customer's connection could potentially cause an outage. Face-to-face coordination is preferred. After attempts of face-to-face or telephone notification are unsuccessful, written notices may be used.

5.10 AS-BUILT DRAWINGS. The Contractor shall provide an as-built drawing of the completed project to Madison County. Appendix D., Figure 11 is a sample of an acceptable as-built drawing. The drawing will include the size of the installed water main, the location of the installed water main, and location and type of valves associated with the installed water main. Location of main should be annotated with footage from road centerlines and include side of road (N, S, E, W) the main is on.

(a) Valves should be annotated by measuring the distance, in feet, and direction (N, S, E, W) from the centerline of an addressed driveway and a road centerline.

(b) Valve distances and directions should not be located off of power poles, mailboxes, road signs, trees, fence posts or buildings. If the Contractor feels it is necessary to locate a valve off of one of the previously listed items, the MCR should be contacted first.

(c) It is not required that the Drawing be computer generated. If the Drawing is hand written, the Contractor should make sure the Drawing is neat and legible. If the Contractor fails to submit an acceptable As-Built Drawing to MCWD, the project will be considered incomplete.

APPENDICES

A. FORMS

A.1 BID FORM.....A-2
A.2 BID BOND.....A-5
A.3 UNAUTHORIZED ALIEN AFFIDAVIT.....A-6
A.4 SWORN AFFIDAVIT OF EMPLOYER REGARDING UNAUTHORIZED
ALIENSA-7
A.5 SWORN AFFIDAVIT FOR SUBCONTRACTORS REGARDING
UNAUTHORIZED ALIENSA-8
A.6 CONTRACTOR’S QUESTIONNAIREA-9
A.6 SUBCONTRACTOR LISTA-12

B. CONTRACT DOCUMENTS (SAMPLE)

B.1 CONSTRUCTION CONTRACT.....A-13
B.2 PAYMENT BOND.....A-15
B.3 PERFORMANCE BONDA-17

C. SITE DRAWINGS

C.1 CONSTRUCTIONA-20

D. DETAILED DRAWINGS

FIGURE 1 EARTH EXCAVATION FOR PVC AND DUCTILE IRON.....A-21
FIGURE 2 ROCK EXCAVATION FOR PVC AND DUCTILE IRON.....A-22
FIGURE 3 DITCH AND OBSTRUCTION CROSSING DETAILA-23
FIGURE 4 DEAD END ANCHOR BLOCK DETAILA-24
FIGURE 5 BLOW OFF DETAIL.....A-25
FIGURE 6 WATER MAIN TRENCH DETAIL.....A-26
FIGURE 7 CONCRETE THRUST BLOCK DETAIL.....A-27
FIGURE 8 VALVE BOX DETAIL.....A-28
FIGURE 9 FIRE HYDRANT INSTALLATION.....A-29
FIGURE 10 SERVICE LINE INSTALLATIONA-30
FIGURE 11 SAMPLE AS-BUILT DRAWING.....A-31

A.1 BID FORM

To: Madison County Commission,

Date:

In compliance with your Advertisement for Bids and subject to all the conditions thereof, the undersigned (Legal Name of Bidder)

hereby proposes to furnish all labor and materials and perform all work required for the Work

Morningview Road Water Main Upgrade Project, Project Number MCWD 16-004, dated March 2016.

The Bidder, which is organized and existing under the laws of the State of _____, having its principal offices in the City of _____, is:

__ Corporation, __ Partnership Individual, ____(Other) _____

LISTING OF PARTNERS OR OFFICERS: If Bidder is a Partnership, list all partners and their addresses; if Bidder is a Corporation, list the names, titles, and business addresses of its officers:

BIDDER’S REPRESENTATION: The Bidder declares that it has examined the site of the Work, having become fully informed regarding all pertinent conditions, and that it has examined the Specifications (including all Addenda received) for the Work and the other Bid and Contract Documents relative thereto, and that it has satisfied itself relative to the Work to be performed.

ADDENDA: The Bidder acknowledges receipt of Addenda Numbers. _____ through _____ inclusively.

Base Bid Calculation Table

Instructions for Completion: Multiply Column A by Column B and total in Column C for Bid items that are per foot or per unit. For bid items that are a lump sum include the total cost in Column C only. The total of Column C will be the Base Bid Total on page 1 of this form.

Bid Items		Bid Evaluation		
Item	Unit	A Unit Price	B Bid Quantity	C Extended Amount
Wattle Ditch Checks	EA		10	
12" DI Water Main Installation	LS			
Rock Excavated for 12" Main (85%)	LF		3,655	
Air Relief Valve Assembly Installation	EA		2	
Gate Valve Assembly Installation	EA		4	
Fire Hydrant Assembly Installation	EA		5	
Long Side Service (Bore)	EA		15	
Long Side Service (Open-Cutting if Boring Fails)	EA		15	
Short Side Service	EA		9	
New Meter Installation	EA		24	
8" DI Main Connection	LS			
Pressure Testing and Disinfection	LS			
Driveway/Culvert Repair	LS			
Landscaping	LS			
			Total	

BASE LUMP SUM BID:

(Total from Column C from Base Bid Calculation Table on page 2 of this form)

Base Bid Total

For the Work complete as specified, the sum of _____

_____ Dollars (\$_____) is bid.

BID SECURITY: The undersigned agrees to enter into a Construction Contract and furnish the prescribed Performance and Payment Bonds and evidence of insurance within fifteen calendar days, or such other period stated in the Bid Documents, after the contract forms have been presented for signature, provided such presentation is made within 60 calendar days after the opening of bids, or such other period stated in the Bid Documents. As security for this

condition, the undersigned further agrees that the funds represented by the Bid Bond (or cashier's check) attached hereto may be called and paid into the account of the Awarding Authority as liquidated damages for failure to so comply.

Attached hereto is a: *(Mark the appropriate box and provide the applicable information.)*

Bid Bond, executed by _____ as Surety,
cashier's check on the _____ Bank _____,
for the sum of _____ Dollars
(\$ _____) made payable to the Awarding Authority.

BIDDER'S ALABAMA GENERAL CONTRACTORS LICENSE:

License Number	Bid Limit	Type(s) of Work
----------------	-----------	-----------------

CERTIFICATIONS: The undersigned certifies that he or she is authorized to execute contracts on behalf of the Bidder as legally named, that this proposal is submitted in good faith without fraud or collusion with any other bidder, that the information indicated in this document is true and complete, and that the bid is made in full accord with State law. Notice of acceptance may be sent to the undersigned at the address set forth below.

The Bidder also declares that a list of all proposed major subcontractors and suppliers will be submitted at a time subsequent to the receipt of bids as established by the Owner in the Bid Documents but in no event shall this time exceed twenty-four (24) hours after receipt of bids.

I hereby certify that I have read and understand Madison County's general terms and conditions and affirm that I have not been in any agreement or collusion among bidders or prospective bidders in restraint of freedom of competition. Upon award of this bid, I will not substitute any item on this bid under any circumstances. I also understand that the general terms and conditions are standard and that any contradicting requirements of the IFB or RFP supercede.

Legal Name of Bidder _____

Mailing Address _____

*** By (Legal Signature)** _____

* Name (type or print) _____

*Title _____

Telephone Number _____

* If other than the individual proprietor, or an above named member of the Partnership, or the above named president, vice-president, or secretary of the Corporation, attach written authority to bind the Bidder. Any modification to a bid shall be over the initials of the person signing the bid, or of an authorized representative.

A.2 BID BOND

The PRINCIPAL:

The SURETY:

The OWNER: Madison County, Alabama, Madison County Courthouse, 100 Northside Square, Huntsville, Alabama 35801

The PROJECT for which the Principal's Bid is submitted: Morning View Road Water Main Upgrade, dated March 2016.

KNOW ALL MEN BY THESE PRESENTS, that we, the undersigned Principal and Surety, jointly and severally, hereby bind ourselves, our heirs, executors, administrators, successors, and assigns to the Owner in the PENAL SUM of five percent (5%) of the amount of the Principal's bid.

THE CONDITION OF THIS OBLIGATION is that the Principal has submitted to the Owner the attached bid, which is incorporated herein by reference, for the Project identified above.

NOW, THEREFORE, if, within the terms of the Bid Documents, the Owner accepts the Principal's bid and the Principal thereafter either:

(a) executes and delivers a Construction Contract with the required Performance and Payment Bonds (each in the form contained in the Bid Documents and properly completed in accordance with the bid) and delivers evidence of insurance as prescribed in the Bid Documents, or

(b) fails to execute and deliver such Construction Contract with such Bonds and evidence of insurance, but pays the Owner the difference, not to exceed the Penal Sum of this Bond, between the amount of the Principal's Bid and the larger amount for which the Owner may award a Construction Contract for the same Work to another bidder, then, this obligation shall be null and void, otherwise it shall remain in full force and effect.

The Surety, for value received, hereby stipulates and agrees that the obligation of the Surety under this Bond shall not in any manner be impaired or affected by any extension of the time within which the Owner may accept the Principal's bid, and the Surety does hereby waive notice of any such extension.

SIGNED AND SEALED this _____ day of _____, _____.

ATTEST:

PRINCIPAL:

By _____

Name and Title

SURETY:

ATTEST

By _____

Name and Title

A.3 UNAUTHORIZED ALIENS AFFIDAVIT

EACH VENDOR SUBMITTING A BID MUST COMPLETE AND SUBMIT WITH ITS BID THE FOLLOWING STATEMENT

STATE OF ALABAMA
MADISON COUNTY

VERIFIED STATEMENT REGARDING UNAUTHORIZED ALIENS

The undersigned hereby certifies, under oath, in regard to the performance of the services or for the supply of materials or things described in this Invitation for Bid, that:

(A) it has conducted a verification, pursuant to all federal and state laws, of all the employees who will perform work on the Madison County Commission contract or work on the materials or things supplied to the Madison County Commission in response to this Invitation for Bid to insure that no unauthorized aliens will be employed to perform Madison County Commission work or supply materials or things to the Madison County Commission,

and

(B) to the best of their knowledge and belief, it is not employing or otherwise using unauthorized aliens to provide services, materials or things to the Madison County Commission.

The undersigned agrees:

1. it will verify that whether an employee is an unauthorized alien by inspecting such documents as are designated by Federal Law. For contracts in excess of \$100,000.00, in any twelve (12) month period of time, the contractor or supplier shall certify to the Commission that it has and will verify, to the extent allowable by Federal Law, by using the Federal E-Verify program, that no unauthorized aliens are utilized in providing services, materials or things to the Commission;

2. upon request, it will certify to the Commission, under oath by an officer or a management level employee, that it has verified to the extent allowable under Federal Law that named or otherwise described employees utilized in providing services, materials or things to the Commission are not unauthorized aliens;

3. upon determination by any appropriate Federal Agency that an employee is an unauthorized alien, the undersigned shall terminate the unauthorized alien's employment.

4. if the undersigned fails to terminate an employee determined to be an unauthorized alien by the Federal government or fails to provide the verification described above, the Madison County Commission may terminate the contract for the performance of services, materials or things pursuant to Madison County, Alabama, Policy Regarding The Employment of Unauthorized Aliens by Contractors and Suppliers.

The requirements and obligations of this Policy and Statement shall be interpreted and implemented in a manner consistent with all Federal and State Laws. If any provision of this Policy or Statement is declared invalid or in conflict with Federal or State Laws, such invalidly or conflict shall not affect the other provisions of this Policy or Statement which can be given effect without the invalid provision. The provisions of this Policy and Statement are declared to be severable.

NAME:

BY: _____

Printed Name of Person Signing: _____

Position: _____

SWORN TO and subscribed before me on this the _____ day of _____, 20 _____.

Notary Public

My Commission Expires: _____

A.4 SWORN AFFIDAVIT OF EMPLOYER REGARDING UNATHORIZED ALIENS

1. The undersigned hereby attests by this sworn affidavit signed before a notary that it does not knowingly employ, hire for employment, or continue to employ an unauthorized alien.

2. The undersigned hereby attests that it is enrolled in the Federal E-Verify program. A true and correct copy of the undersigned's fully executed Federal E-Verify Memorandum of Understanding is attached hereto.

3. The Federal E-Verify Memorandum of Understanding attached hereto is the operative Memorandum of Understanding under which the undersigned is currently participating in the Federal E-Verify Program.

4. This sworn affidavit is provided to comply with Alabama Act No. 2011-535, known as the "Beason-Hammon Alabama Taxpayer and Citizen Protection Act."

Name: _____

By: _____

Printed Name: _____

Position: _____

STATE OF ALABAMA

COUNTY OF MADISON

I, the undersigned, Notary Public in and for said County in said State, hereby certify that _____, whose name as _____ of _____, is signed to the foregoing instrument and who is known to me, acknowledged before me on this day that, being informed of the contents of the instrument, he, as such _____ and with full authority, executed the same voluntarily for and as the act of said _____.

Given under my hand this the ____ day of _____, 20__.

Notary Public
My Commission Expires: _____

A.5. SWORN AFFIDAVIT OF SUBCONTRACTOR REGARDING UNATHORZIED ALIENS

1. The undersigned subcontractor hereby attests by this sworn affidavit signed before a notary that it does not knowingly employ, hire for employment, or continue to employ an unauthorized alien.

2. The undersigned subcontractor hereby attests that it is enrolled in the Federal E-Verify program. A true and correct copy of the undersigned's fully executed Federal E-Verify Memorandum of Understanding is attached hereto.

3. The Federal E-Verify Memorandum of Understanding attached hereto is the operative Memorandum of Understanding under which the undersigned is currently participating in the Federal E- Verify Program.

4. This sworn affidavit is provided to comply with Alabama Act No. 2011-535, known as the "Beason-Hammon Alabama Taxpayer and Citizen Protection Act."

Name: _____

By: _____

Printed Name: _____

Position: _____

STATE OF ALABAMA

COUNTY OF MADISON

I, the undersigned, Notary Public in and for said County in said State, hereby certify that

_____, whose name as _____ of _____, is signed to the foregoing instrument and who is known to me, acknowledged before me on this day that, being informed of the contents of the instrument, he, as such _____ and with full authority, executed the same voluntarily for and as the act of said _____.

Given under my hand this the ____ day of _____, 20__.

Notary Public

My Commission Expires: _____

A.6 CONTRACTOR'S QUESTIONNAIRE

1. General Information

1.1 Name of Firm: _____
Street Address: _____
Mailing Address: _____
Phone Number: _____
Email Address: _____
Point of Contact: _____

1.2 Date your firm was organized: _____
Legal form of business: Corporation: _____
Individual: _____
Partnership: _____
Joint Venture: _____
Other: _____
Federal I.D. #: _____
Subsidiary of another company? _____
Parent Company Name: _____

1.3 In what states are you licensed to do business? _____
Alabama Contractor's License Number: _____

1.4 Number of full-time office employees: _____
Number of full-time permanent field employees: _____

1.5 If you answer yes to any of the following questions, please attach a brief explanation and contact info persons who may be contacted for additional information (indicate yes or no):

- a) Are there any claims, arbitration proceedings or suits pending against your organization? _____
- b) Within the last 5 years, has your organization filed any lawsuits or requested arbitration related to construction contracts? _____
- c) Within the last 5 years, has your organization failed to complete work awarded to it? _____
- d) Has your organization ever been adjudged bankrupt or filed a petition in bankruptcy? _____
- e) Within the last 5 years, has your organization been assessed liquidated damages for failure to complete a project by the contract date? _____
- f) Within the last 3 years, has your organization received a final order for willful or repeated violations issued by OSHA or the Alabama Department of Labor or other government agency? _____

g) Have any Performance Bond or Payment Bond claims ever been paid by any surety on behalf of your organization? _____

2. Contractor's Experience and Additional Info

2.1 Number of years doing similar work which you are bidding? _____

Approximate number of projects that your organization has completed that are similar to the work you are bidding? _____

Has your organization ever performed work that required a significant amount of rock excavation? _____

If yes to question above, what rock removal method(s)/ equipment were used? _____

Has your organization ever performed work that involved blasting? _____

2.2 List major and/or similar projects completed within the last 5 years:

2.3 Attach a list of major projects in progress. Include cost of construction and anticipated completion date.

2.4 What percentage of the contract amount do you typically perform with your own forces? _____

Identify work normally performed with your own forces or projects similar to the one for which your firm is bidding? _____

3. References

3.1 Does the Owner have concurrences of the Contractor to contact any and all references included? (answer yes or no): _____

3.2 OWNER/CLIENT

Owner/Client #1: _____

Street Address: _____

City/State/Zip: _____

Owner/Client #2: _____

Street Address: _____

City/State/Zip: _____

Owner/Client #3: _____

Street Address: _____

City/State/Zip: _____

4. Certification

4.1 *The undersigned certifies under oath that the information provided herein is true and sufficiently complete so as to not be misleading.*

Signature: _____

Date: _____

B.1 CONSTRUCTION CONTRACT

This Construction Contract is entered into this _____ day of _____, between Madison County, Alabama (“Owner”), Madison County Courthouse, 100 Northside Square, Huntsville, AL 35801 and _____ (“Contractor”), _____ Address _____ for the Work of the Project, identified as:

Morning View Road Water Main Upgrade Project, Project Number MCWD 16-004

The CONTRACT DOCUMENTS are dated March 2016, and have been amended by

ADDENDA _____

Bid Items		Bid Evaluation		
Item	Unit	A Unit Price	B Bid Quantity	C Extended Amount
Wattle Ditch Checks	EA		10	
12” DI Water Main Installation	LS			
Rock Excavated for 12” Main (85%)	LF		3,655	
Air Relief Valve Assembly Installation	EA		2	
Gate Valve Assembly Installation	EA		5	
Fire Hydrant Assembly Installation	EA		6	
Long Side Service (Bore)	EA		15	
Long Side Service (Open-Cut if Boring Fails)	EA		15	
Short Side Service	EA		9	
New Meter Installation	EA		24	
8” DI Main Connection	LS			
Pressure Testing and Disinfection	LS			
Driveway/Culvert Repair	LS			
Landscaping	LS			
			Total	

The CONTRACT SUM is _____ Dollars

(\$ _____) and is the sum of the Contractor’s Base bid for the Work and the following:

BID ALTERNATE PRICES: NONE

BID OPTION: NONE

UNIT PRICE ITEMS: NONE

The **CONTRACT TIME** is one hundred eighty (180) calendar days.

THE OWNER AND THE CONTRACTOR AGREE AS FOLLOWS:

The Contract Documents, as defined in the General Conditions of the Contract are incorporated herein by reference. The Contractor shall perform the Work in accordance with the Contract Documents. The Owner will pay and the Contractor will accept as full compensation for such performance of the Work, the Contract Sum subject to additions and deductions (including liquidated damages) as provided in the Contract Documents. The Work shall be commenced on a date to be specified in the Notice to Proceed.

LIQUIDATED DAMAGES for which the Contractor and its Surety (if any) shall be liable and may be required to pay the Owner in accordance with the Contract Documents shall be equal to four hundred and 00/100 Dollars (\$400.00) per calendar day.

STATE GENERAL CONTRACTOR'S LICENSE: The Contractor does hereby certify that Contractor is currently licensed by the Alabama State Licensing Board for General Contractors and that the certificate for such license bears the following:

_____	_____	_____
License No.	Bid Limit:	Classification:

The Owner and Contractor have entered into this Construction Contract as of the date first written above and have executed this Construction Contract in sufficient counterparts to enable each contracting party to have an originally executed Construction Contract each of which shall, without proof or accounting for the other counterparts, be deemed an original thereof.

The Owner does hereby certify that this Construction Contract was let in accordance with the provisions of Title 39, Code of Alabama 1975, as amended, and all other applicable provisions of law.

CONTRACTING PARTIES

Contractor

MADISON COUNTY, ALABAMA

By _____

By _____

Name

Dale W. Strong, Chairman,
Madison County Commission

Title

B.2 PAYMENT BOND

SURETY'S BOND NUMBER

The PRINCIPAL

The SURETY

The OWNER

Madison County, Alabama, Madison County Courthouse, 100 Northside Square, Huntsville, Alabama 35801

The PENAL SUM of this Bond (the Contract Sum):

DATE of the Construction Contract:

The PROJECT:

Morning View Road Water Main Upgrade Project, Project Number MCWD 2016-004, Bid 2016-XX, dated March 2016.

1. WE, THE PRINCIPAL (hereinafter "Contractor") AND THE SURETY, jointly and severally, hereby bind ourselves, our heirs, executors, administrators, successors, and assigns to the Owner in the Penal Sum stated above to promptly pay all persons supplying labor, materials, or supplies for or in the prosecution of the Contract, which is incorporated herein by reference, and any modifications thereof by Contract Change Orders. If the Contractor and its Subcontractors promptly pay all persons supplying labor, materials, or supplies for or in the prosecution of the Contract and Contract Change Orders, then this obligation shall be null and void; otherwise to remain and be in full force and effect.

2. The Penal Sum shall remain equal to the Contract Sum as the Contract Sum is adjusted by Contract Change Orders. All Contract Change Orders involving an increase in the Contract Sum will require consent of Surety by endorsement of the Contract Change Order form. The Surety waives notification of any Contract Change Orders involving only extension of the Contract Time.

3. Any person that has furnished labor, materials, or supplies for or in the prosecution of the Contract and Contract Change Orders for which payment has not been timely made may institute a civil action upon this Bond and have their rights and claims adjudicated in a civil action and judgment entered thereon. Notwithstanding the foregoing, a civil action may not be instituted on this bond until 45 days after written notice to the Surety of the amount claimed to be due and the nature of the claim. The civil action must commence not later than one year from the date of final settlement of the Contract. The giving of notice by registered or certified mail, postage prepaid, addressed to the Surety at any of its places of business or offices shall be deemed sufficient. In the event the Surety or Contractor fails to pay the claim in full within 45 days from the mailing of the notice, then the person or persons may recover from the Contractor and Surety, in addition to the amount of the claim, a reasonable attorney's fee based on the result, together with interest on the claim from the date of the notice.

4. Every person having a right of action on this bond shall, upon written application to the Owner indicating that labor, material, or supplies for the Work have been supplied and that payment has not been made, be promptly furnished a certified copy of this bond and the Construction Contract. The claimant

may bring a civil action in the claimant's name on this Bond against the Contractor and the Surety, or either of them, in the county in which the Work is to be or has been performed or in any other county where venue is otherwise allowed by law.

5. This bond is furnished to comply with Code of Alabama, §39-1-1, and all provisions thereof shall be applicable to civil actions upon this bond.

6. All claims and disputes between Owner and either the Contractor or Surety arising out of or related to this bond, or its breach, shall be resolved in accordance with Section 3.24, General Conditions of the Contract

SIGNED AND SEALED this _____ day of _____, _____ .

ATTEST: CONTRACTOR as PRINCIPAL:

By _____

Name and Title

Countersigned by

Alabama Resident Agent for Surety:

Surety:

By _____

Name

By _____

Address

Name and Title

NOTE: Power of attorney for the Surety's signatory shall be furnished with the original and three copies of the bond.

B.3. PERFORMANCE BOND

The PRINCIPAL

The SURETY

The OWNER

Madison County, Alabama, Madison County Courthouse, 100 Northside Square, Huntsville, Alabama 35801

The PENAL SUM of this Bond (the Contract Sum):

DATE of the Construction Contract:

The PROJECT:

Morning View Road Water Main Upgrade Project, Project Number MCWD 2016-004, Bid 2016-XX, dated March 2016.

1. WE, THE PRINCIPAL (hereinafter “Contractor”) AND THE SURETY, jointly and severally, hereby bind ourselves, our heirs, executors, administrators, successors, and assigns to the Owner in the Penal Sum stated above for the performance of the Contract, and Contract Change Orders, in accord with the requirements of the Contract Documents, which are incorporated herein by reference. If the Contractor performs the Contract, and Contract Change Orders, in accordance with the Contract Documents, then this obligation shall be null and void; otherwise it shall remain in full force and effect.
2. The Penal Sum shall remain equal to the Contract Sum as the Contract Sum is adjusted by Contract Change Orders. All Contract Change Orders involving an increase in the Contract Sum will require consent of Surety by endorsement of the Contract Change Order form. The Surety waives notification of any Contract Change Orders involving only extension of the Contract Time.
3. Whenever the Owner gives the Contractor and the Surety, at their addresses stated above, a written Notice to Cure a condition for which the Contract may be terminated in accordance with the Contract Documents, the Surety may, within the time stated in the notice, cure or provide the Owner with written verification that satisfactory positive action is in process to cure the condition.
4. The Surety’s obligation under this Bond becomes effective after the Contractor fails to satisfy a Notice to Cure and the Owner:
 - (a) gives the Contractor and the Surety, at their addresses stated above, a written Notice of Termination declaring the Contractor to be in default under the Contract and stating that the Contractor’s right to complete the Work, or a designated portion of the Work, shall terminate seven days after the Contractor’s receipt of the notice; and
 - (b) gives the Surety a written demand that, upon the effective date of the Notice of Termination, the Surety promptly fulfill its obligation under this Bond.
5. In the presence of the conditions described in Paragraph 4, the Surety shall, at its expense:
 - (a) On the effective date of the Notice of Termination, take charge of the Work and be responsible for the safety, security, and protection of the Work, including materials and

equipment stored on and off the Project site, and

(b) Within twenty-one days after the effective date of the Notice of Termination, proceed, or provide the Owner with written verification that satisfactory positive action is in process to facilitate proceeding promptly, to complete the Work in accordance with the Contract Documents, either with the Surety's resources or through a contract between the Surety and a qualified contractor to whom the Owner has no reasonable objection.

6. As conditions precedent to taking charge of and completing the Work pursuant to Paragraph 5, the Surety shall neither require, nor be entitled to, any agreements or conditions other than those of this Bond and the Contract Documents. In taking charge of and completing the Work, the Surety shall assume all rights and obligations of the Contractor under the Contract Documents; however, the Surety shall also have the right to assert "Surety Claims" to the Owner in accordance with the Contract Documents. The presence or possibility of a Surety Claim shall not be just cause for the Surety to fail or refuse to promptly take charge of and complete the Work or for the Owner to fail or refuse to continue to make payments in accordance with the Contract Documents.

7. By accepting this Bond as a condition of executing the Construction Contract, and by taking the actions described in Paragraph 4, the Owner agrees that:

(a) the Owner shall promptly advise the Surety of the unpaid balance of the Contract Sum and, upon request, shall make available or furnish to the Surety, at the cost of reproduction, any portions of the Project Record, and

(b) as the Surety completes the Work, or has it completed by a qualified contractor, the Owner shall pay the Surety, in accordance with terms of payment of the Contract Documents, the unpaid balance of the Contract Sum, less any amounts that may be or become due the Owner from the Contractor under the Construction Contract or from the Contractor or the Surety under this Bond.

8. In the presence of the conditions described in Paragraph 4, the Surety's obligation includes responsibility for the correction of Defective Work, liquidated damages, and reimbursement of any reasonable expenses incurred by the Owner as a result of the Contractor's default under the Contract, including architectural, engineering, administrative, and legal services.

9. Nothing contained in this Bond shall be construed to mean that the Surety shall be liable to the Owner for an amount exceeding the Penal Sum of this Bond, except in the event that the Surety should be in default under the Bond by failing or refusing to take charge of and complete the Work pursuant to Paragraph 5. If the Surety should fail or refuse to take charge of and complete the Work, the Owner shall have the authority to take charge of and complete the Work, or have it completed, and the following costs to the Owner, less the unpaid balance of the Contract Sum, shall be recoverable under this Bond:

(a) the cost of completing the Contractor's responsibilities under the Contract, including correction of Defective Work;

(b) additional architectural, engineering, managerial, and administrative services, and reasonable attorneys' fees incident to completing the Work;

(c) interest on, and the cost of obtaining, funds to supplement the unpaid balance of the Contract Sum as may be necessary to cover the foregoing costs;

(d) the fair market value of any reductions in the scope of the Work necessitated by insufficiency of the unpaid balance of the Contract Sum and available supplemental funds to cover the foregoing costs; and

(f) additional architectural, engineering, managerial, and administrative services, and

reasonable attorneys' fees incident to ascertaining and collecting the Owner's losses under the Bond.

10. All claims and disputes arising out of or related to this bond, or its breach, shall be resolved in accordance with Section 3.24, General Conditions of the Contract.

SIGNED AND SEALED this _____ day of _____, _____.

ATTEST:

Contractor as Principal:

By _____

Name and Title

Countersigned by
Alabama Resident Agent for Surety:

SURETY:

By _____

By _____

Name

Name and Title

Address

NOTE: Power of attorney for the Surety's signatory shall be furnished with the original and three copies of the bond

C.1. CONSTRUCTION DRAWING

Madison County Water Department

Morning View Road Water Main Upgrade, Phase II

Tie to Existing 12" PVC Main w/ Solid Sleeve.
 Temporary Blow Off for Flushing w/ Thrust Restraint. Refer to Details 4 & 5.
 1" Sample Tap (Remove After Testing)
 Bends Will Be Required.

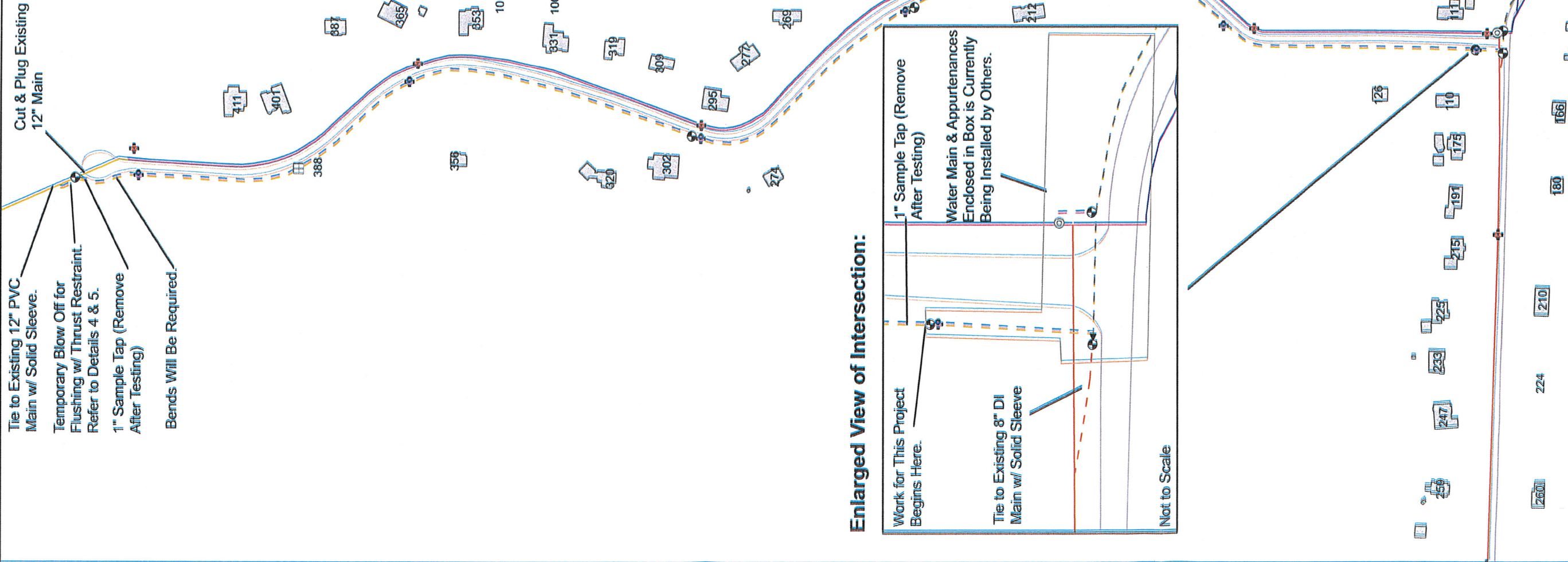

Notes:

- All Locations of Proposed Main, Hydrants and Valves are TBD in Field.
- Contractor Shall Have Existing Utilities Located Prior to Work.
- Valves are to be Operated by MCWD Personnel Only.
- Location of Wattles are TBD in Field by the Engineer.
- Thrust Restraint Required at Tee's and Bends.
- Crushed #57 Stone Bedding is Required Where Rock is Encountered. Refer to Section 5.5 of Technical Specifications.
- The Contractor Must Attempt Boring Services under Morning View Rd for Long Side Services. If Boring Fails, Services Will be Installed by Open-Cutting the Road. Long Side Services Must be Encased in 2.5" Sch 40 PVC. See Figure 8 for Details.
- Contractor to Cut Asphalt According to Section 5.2(g)(ii) and Backfill Open Cut Roads to Grade. Madison County Will Perform Final Saw Cut and Complete Asphalt Paving.
- The 8" and 12" Main Connections Shall be Made Simultaneously/Consecutively to Limit Customer Outage.
- Contractor Shall Remove Old Hydrants, Meters, Meter Boxes, Backflow Preventers and Valve Boxes. Hydrants, Meters and Backflow Preventers are to be Returned to MCWD Warehouse and Valve Boxes and Meter Boxes Disposed by Contractor.
- Ms. Bailee Robinson is the Primary Point of Contact at (256) 746-2871.

Enlarged View of Intersection:

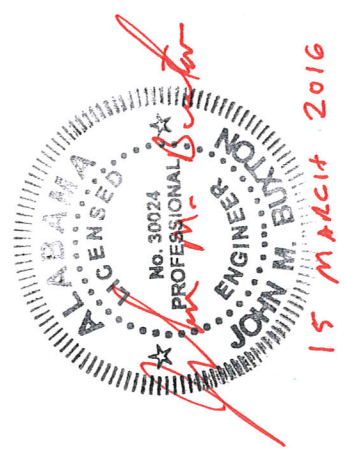
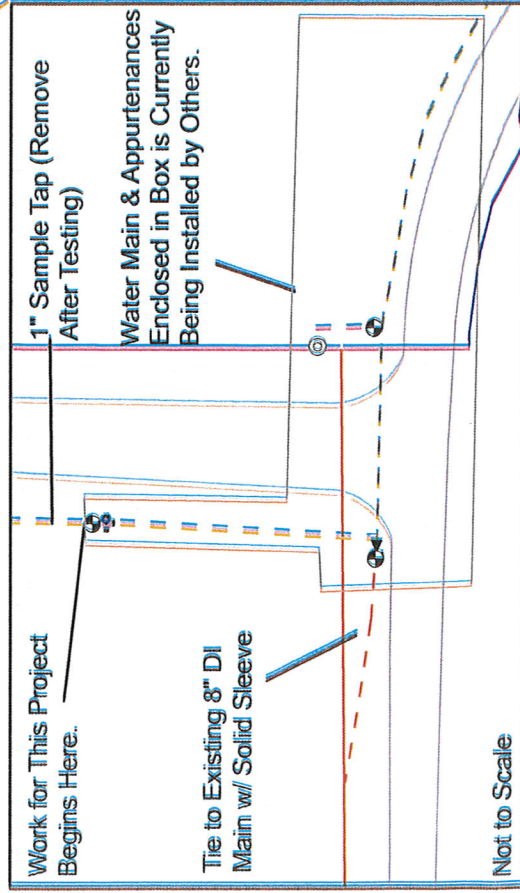

Legend

+	Proposed Hydrant	- - -	Proposed 6" Main
+	Existing Hydrants	- - -	Proposed 8" Main
+	Proposed ARV	- - -	Proposed 12" Main
+	Proposed GV	- - -	Existing 6" Main
+	Proposed Reducer	- - -	Existing 8" Main
+	Proposed TSV	- - -	Pipe 12

FIGURE 1: EARTH EXCAVATION FOR PVC AND DUCTILE IRON

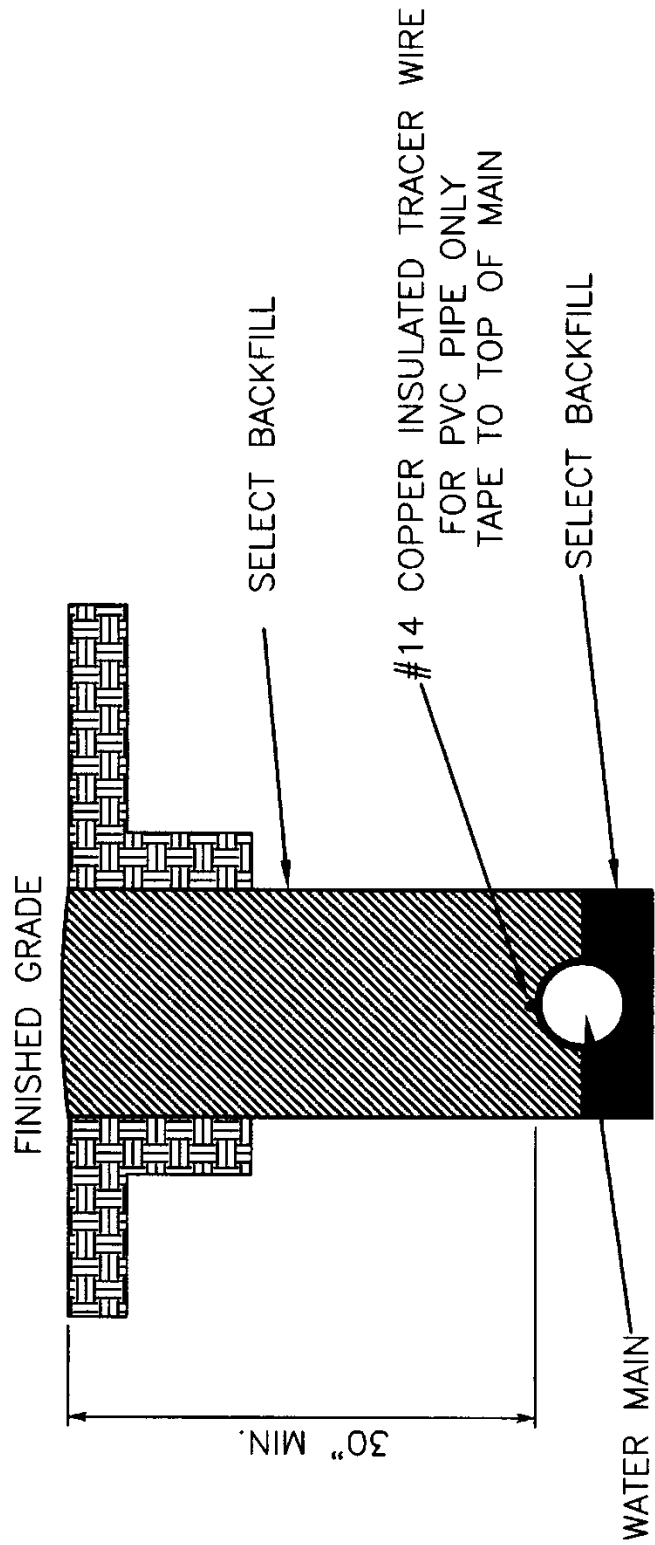

EARTH EXCAVATION FOR PVC & DI

FIGURE 2: ROCK EXCAVAION FOR PVC AND DUCTILE IRON

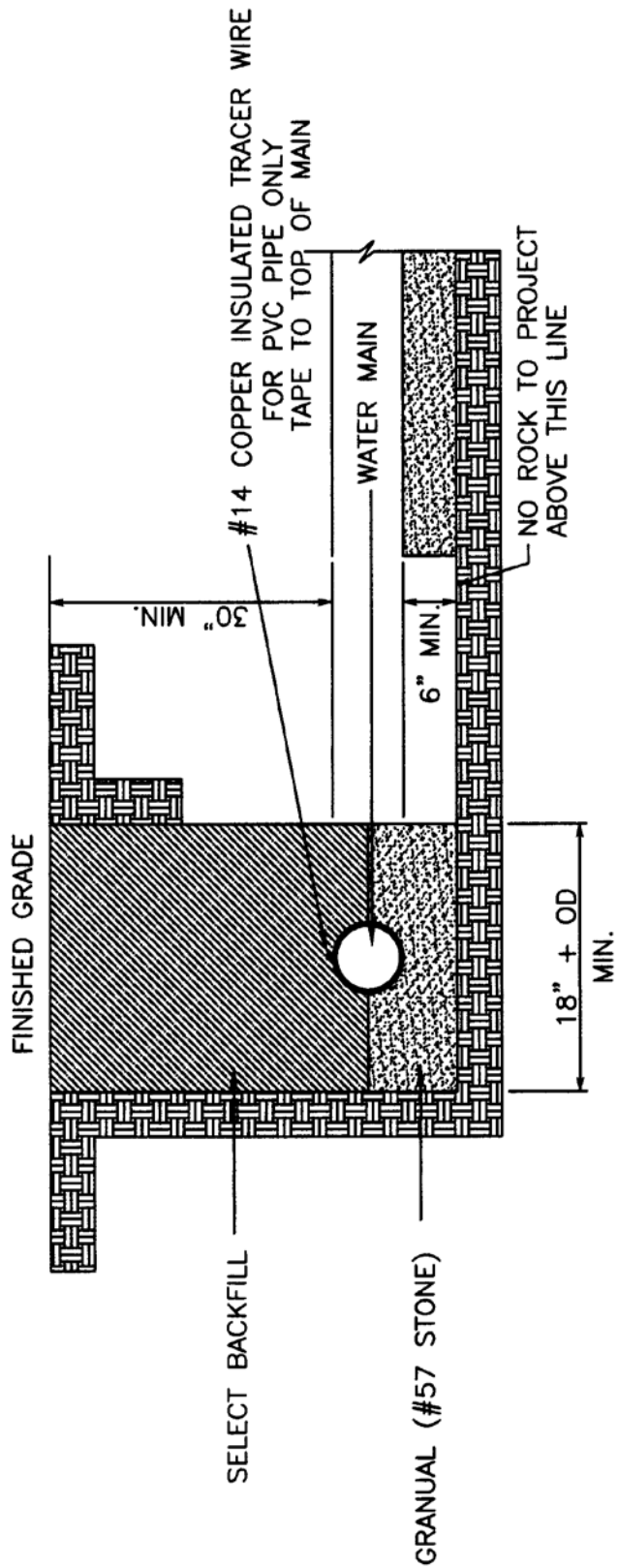

ROCK EXCAVATION FOR PVC & DI

FIGURE 3: DITCH AND OBSTRUCTION CROSSING DETAIL

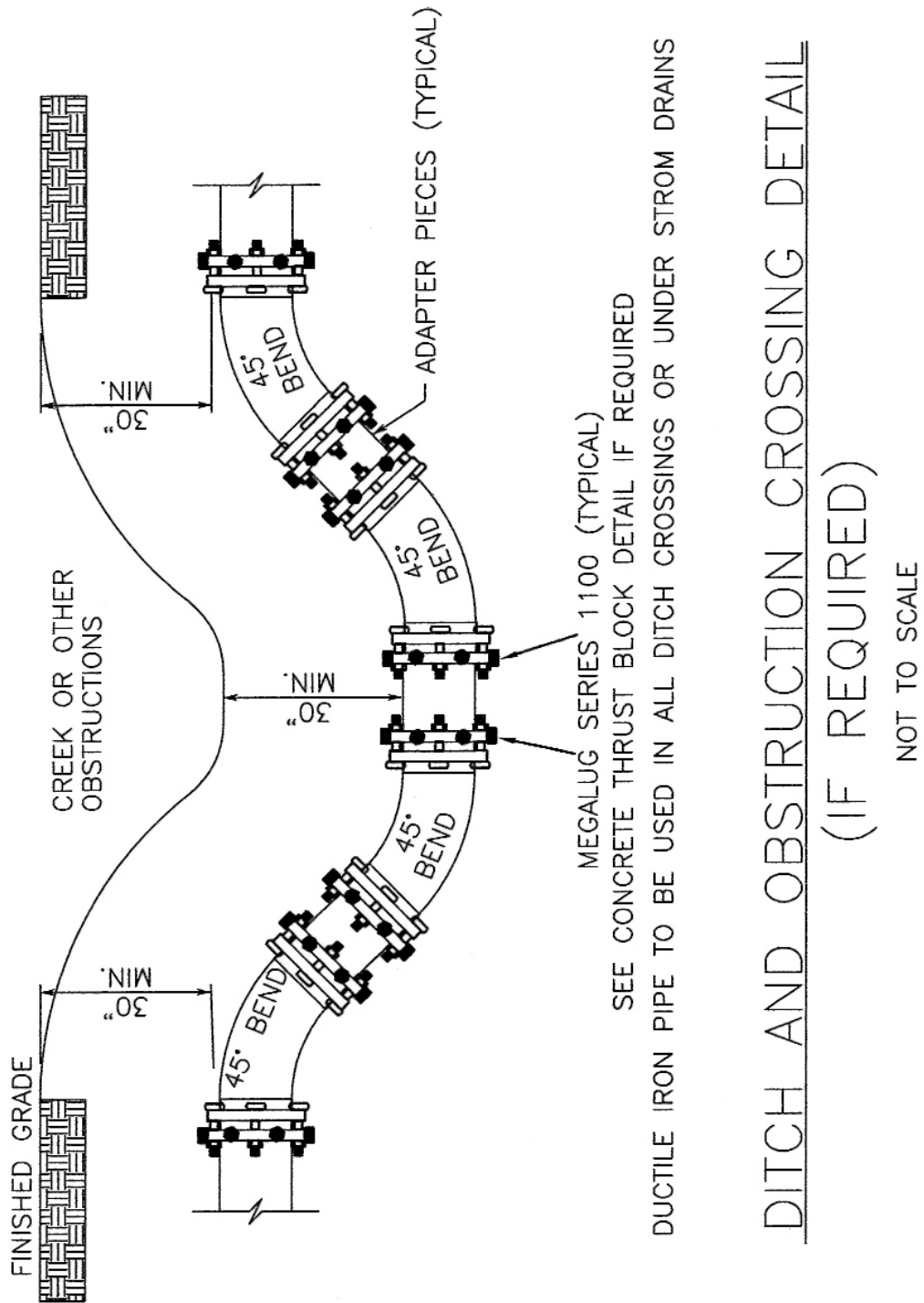
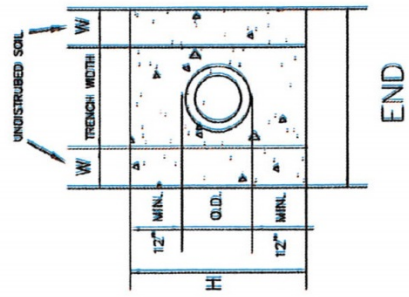
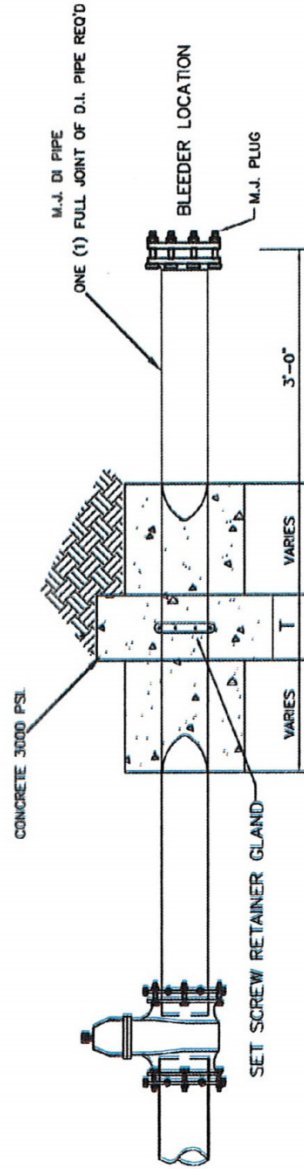

FIGURE 4: DEAD END ANCHOR BLOCK DETAIL

Pipe Size	3"	6"	8"	10"
W	1'	1.5'	2.25'	3.0'
H	2.25'	2.5'	2.75'	3.0'
T	1'	1'	1'	1.5'
Area* (SQFT)	4.5	7.5	12	18



NOTE:
 ALL DEAD END LINES SHALL BE ANCHORED AS SHOWN IN THE DETAIL.
 A VALVE SHALL BE PLACED AT THE JOINT THAT PRECEEDS THE LAST PIPE.
 THE MADISON COUNTY WATER DEPARTMENT WILL DETERMINE THE NEED FOR
 A BLEEDER TO BE PLACED AT THE END OF THE PIPE.
 * AREA AGAINST UNDISTURBED SOIL
 TOTAL WIDTH = 2*W + WIDTH OF TRENCH
 COVER ON WATER MAIN 30" MIN.

DEAD END ANCHOR BLOCK DETAIL
 NOT TO SCALE

FIGURE 5: BLOW OFF DETAIL

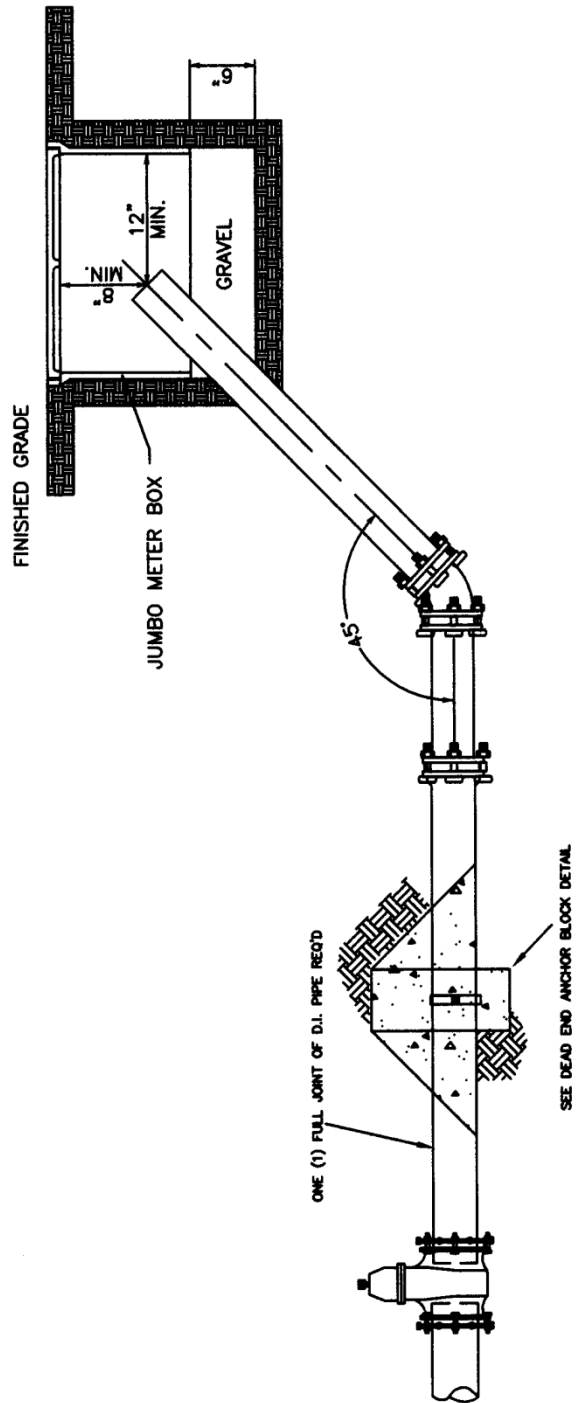

BLOW OFF DETAIL

FIGURE 6: WATER MAIN TRENCH DETAIL

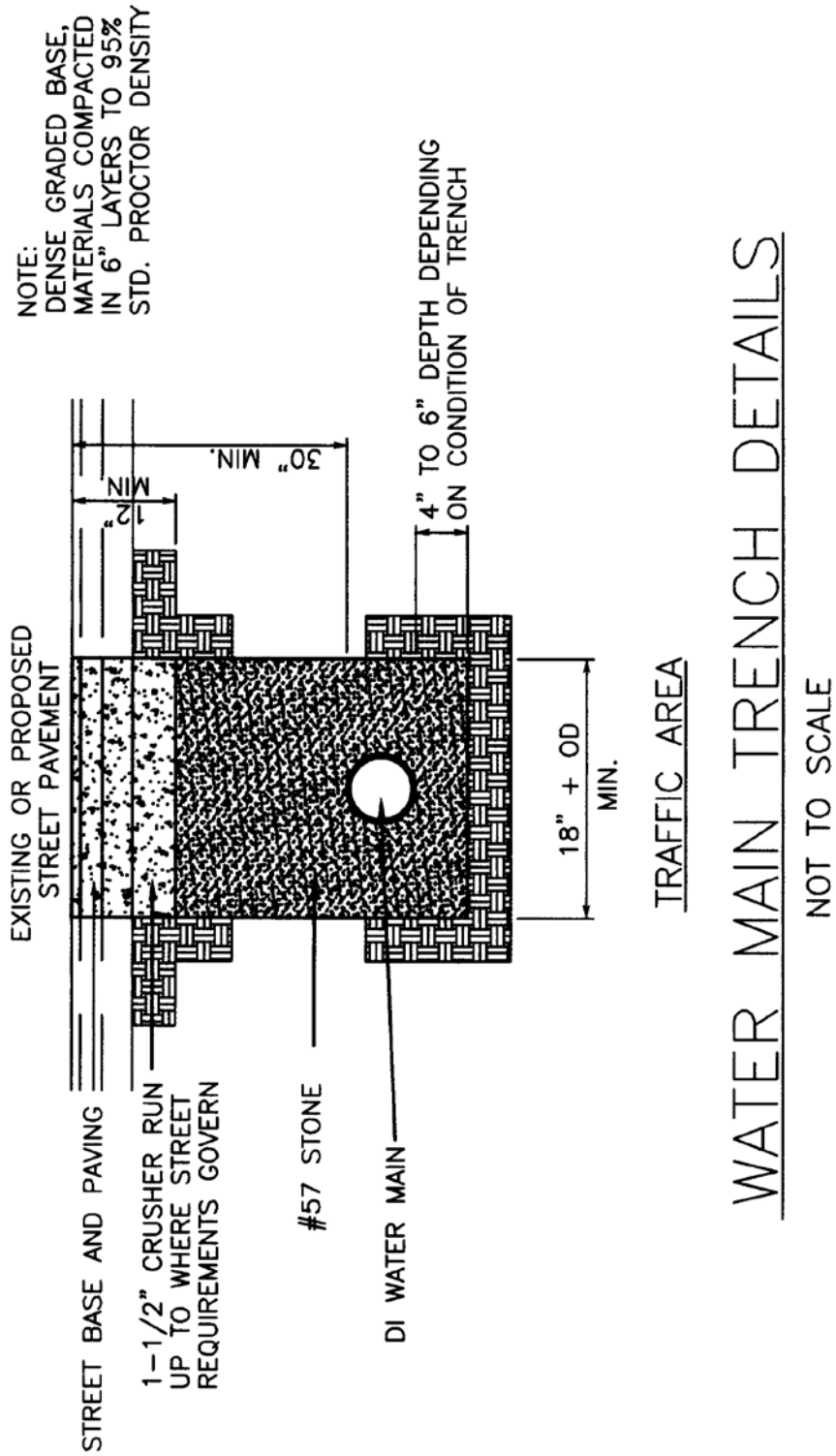
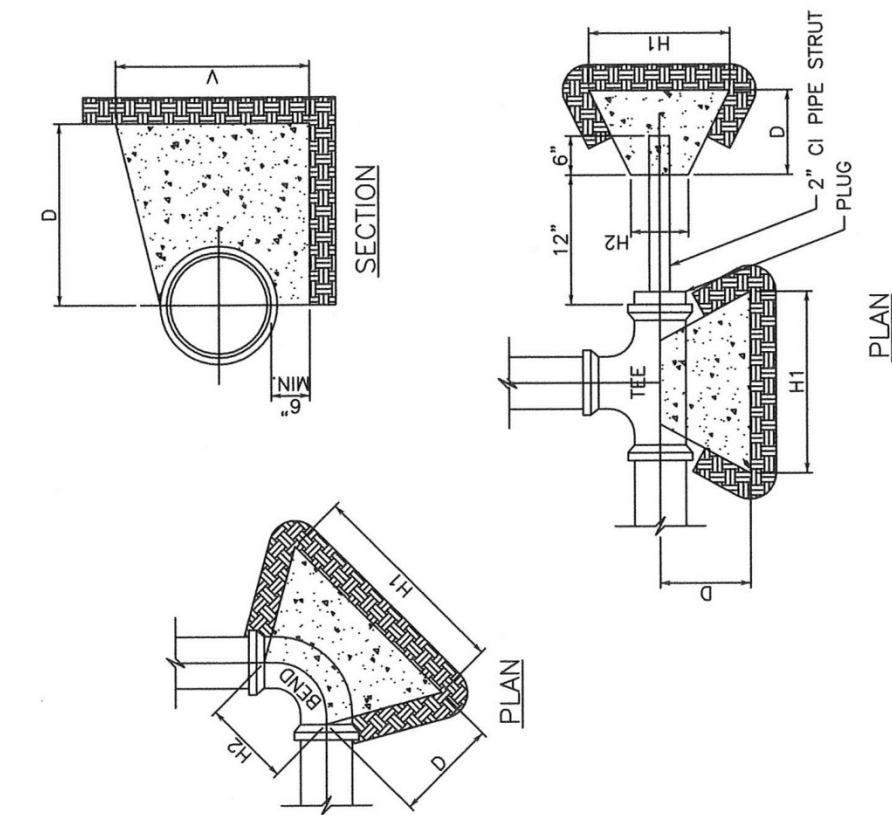

FIGURE 7: CONCRETE THRUST BLOCK DETAIL



PIPE SIZE	11-1/4° BEND		
	H1	H2	D
3"	12"	8"	12"
6"	16"	10"	18"
8"	20"	12"	18"
			V

PIPE SIZE	22-1/2° BEND		
	H1	H2	D
3"	12"	8"	12"
6"	18"	10"	18"
8"	30"	16"	18"
			V

PIPE SIZE	45° BEND		
	H1	H2	D
3"	24"	8"	12"
6"	32"	16"	18"
8"	38"	18"	18"
			V

PIPE SIZE	90° BEND		
	H1	H2	D
3"	24"	12"	12"
6"	38"	18"	18"
8"	58"	24"	24"
			V

PIPE SIZE	TEES & PLUGS		
	H1	H2	D
3"	24"	12"	12"
6"	32"	16"	18"
8"	46"	24"	24"
			V

CONCRETE THRUST BLOCK DETAIL

NOT TO SCALE

FIGURE 8: VALVE BOX DETAIL

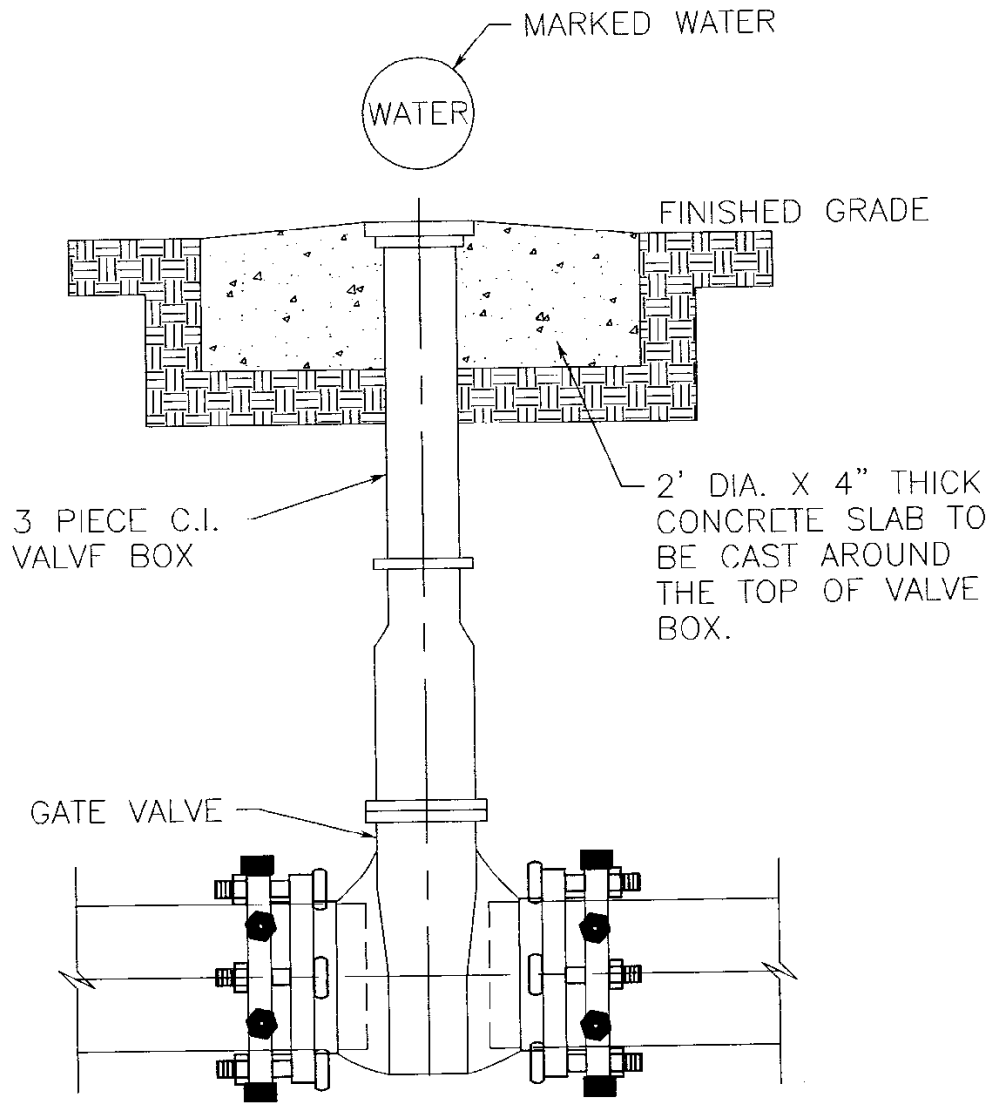

VALVE BOX DETAIL
NOT TO SCALE

FIGURE 9: FIRE HYDRANT INSTALLATION

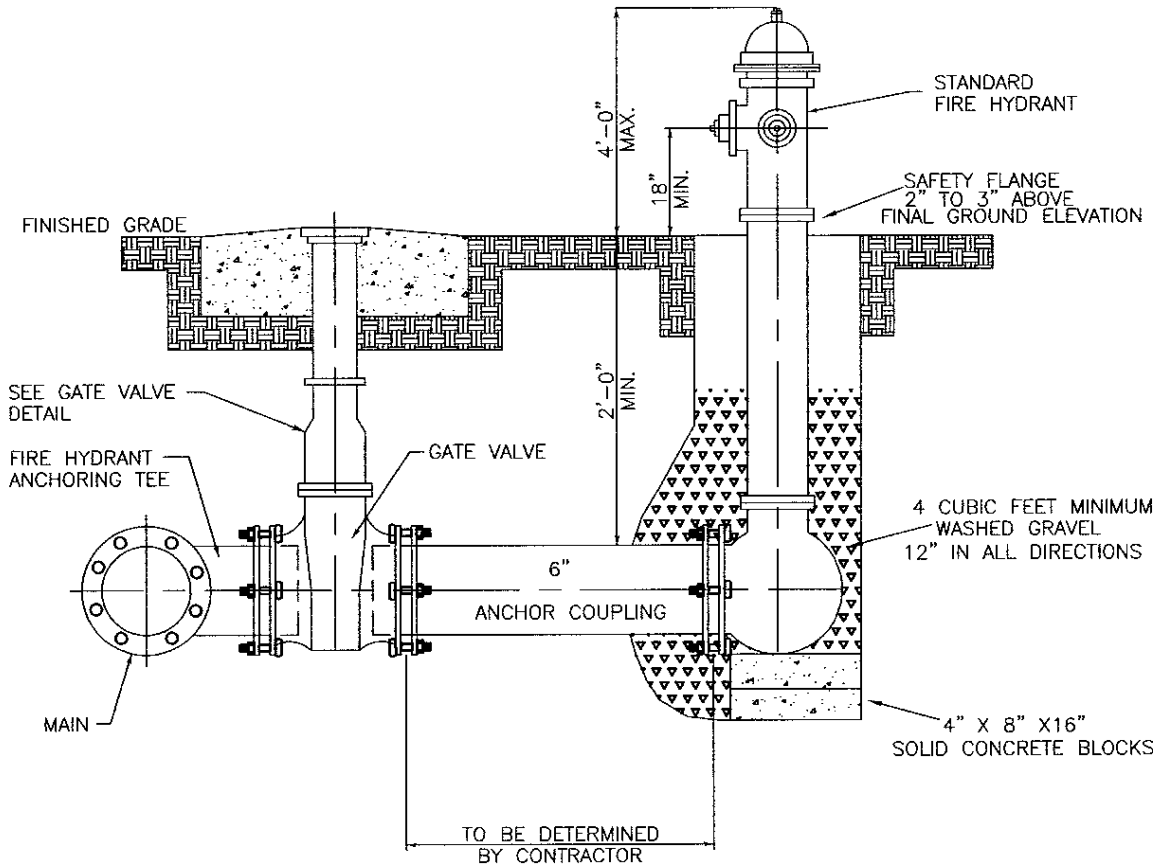

Scar or Paint Damage Hydrants
TO BE RECOATED USING PAINT BRUSH
Safety Yellow enamel
(Pre-Mixed) b54y37

FIRE HYDRANT DETAIL
NOT TO SCALE

FIGURE 10: SERVICE LINE INSTALLATION

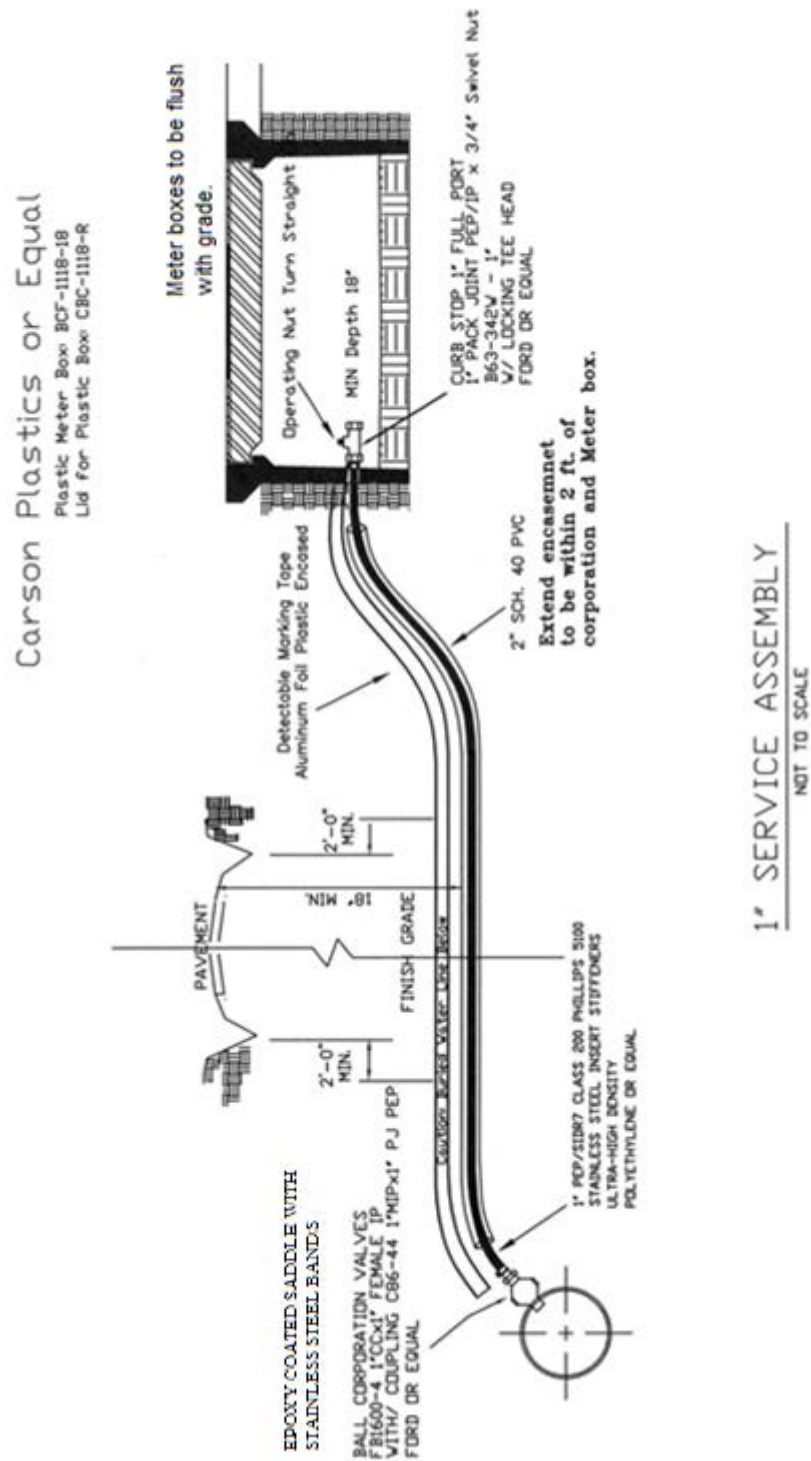

FIGURE 11: SAMPLE AS-BUILT DRAWINGS

